

DEPARTMENT OF THE ARMY TECHNICAL MANUAL

---

ELEMENTARY OPTICS  
AND  
APPLICATION TO  
FIRE CONTROL INSTRUMENTS

---

HEADQUARTERS, DEPARTMENT OF THE ARMY

DECEMBER 1977

**ELEMENTARY OPTICS**  
**AND**  
**APPLICATION TO FIRE CONTROL INSTRUMENTS**

Reporting Errors and Recommending Improvements. You can help improve this manual. If you find any mistake or if you know of a way to improve the procedures, please let us know. Mail your letter, DA Form 2028 (Recommended Changes to Publication and Blank Forms), or DA Form 2028-2 located in the back of this manual direct to: Commander, US Army Armament Materiel Readiness Command, ATTN: DRSAR-MAS, Rock Island, IL 61201. A reply will be furnished

	<b>Paragraph</b>	<b>Page</b>
CHAPTER 1. INTRODUCTION .....	1-1	1-1
CHAPTER 2. PROPERTIES OF LIGHT		
Section I. Light .....	2-1	2-1
II. Reflection .....	2-5	2-9
III. Refraction.....	2-10	2-15
IV. Image formation .....	2-18	2-26
V. Color.....	2-26	2-37
VI. Characteristics of optical systems.....	2-29	2-39
VII. Aberrations and other optical defects .....	2-37	2-42
CHAPTER 3. THE HUMAN EYE		
Section I. General .....	3-1	3-1
II. Construction.....	3-3	3-2
III. Binocular (two-eyed) vision and stereovision.....	3-7	3-7
IV. Defects and limitations of vision.....	3-10	3-14
V. Optical instruments and the eyes.....	3-12	3-17
CHAPTER 4. OPTICAL COMPONENTS, COATED OPTICS, AND CONSTRUCTION FEATURES		
Section I. Optical components .....	4-1	4-1
II. Coated optics .....	4-13	4-31
III. General construction features.....	4-17	4-35
CHAPTER 5. ELEMENTARY PRINCIPLES OF TELESCOPES		
I. Introduction .....	5-1	5-1
II. Astronomical telescopes .....	5-5	5-2
III. Terrestrial telescopes.....	5-8	5-4
IV. Functions of collective lenses and eyepieces .....	5-12	5-8
V. Adjustments .....	5-14	5-10
VI. Functions of telescopic sights .....	5-17	5-12
VII. Optical factors in telescope design .....	5-22	5-13
CHAPTER 6. PRINCIPLES OF LASERS.....	6-1	6-1
CHAPTER 7. INFRARED PRINCIPLES .....	7-1	7-1

\*This manual supersedes TM 9258, May 1966.

	<b>Paragraph</b>	<b>Page</b>
CHAPTER 8. TYPICAL FIRE CONTROL INSTRUMENTS		
Section I. Telescopes.....	8-1	8-1
II. Articulated telescopes.....	8-5	8-3
III. Elbow telescopes.....	8-8	8-5
IV. Panoramic telescopes.....	8-10	8-8
V. Periscopes.....	8-13	8-10
VI. Binoculars.....	8-18	8-16
VII. Range finders.....	8-21	8-19
VIII. Specialized military optical instruments.....	8-24	8-26
CHAPTER 9. TESTING OPTICAL PROPERTIES OF INSTRUMENTS.....	9-1	9-1
CHAPTER 10. MEASUREMENT SYSTEMS EMPLOYED IN OPTICS.....	10-1	10-1
APPENDIX A. REFERENCES.....		A-1
B. GLOSSARY.....		B-1
INDEX.....		I-1

LIST OF ILLUSTRATIONS

Figure	Title	Page
1-1	Military applications of Optics .....	1-2
2-1	Wave carrying energy along rope .....	2-2
2-2	Wave train passing along rope .....	2-3
2-3	Electromagnetic spectrum .....	2-4
2-4	Light sources send waves in all directions .....	2-5
2-5	Light travels in direction of radii of waves.....	2-5
2-6	Waves and radii from nearby light source.....	2-6
2-7	Waves and radii from distant light source .....	2-6
2-8	Speed of light .....	2-7
2-9	Wavelength .....	2-8
2-10	Frequency .....	2-8
2-11	Symbols and types of illustrations used in this manual .....	2-9
2-12	Beam of light reflected back .....	2-10
2-13	Terms used with reference to reflected light .....	2-10
2-14	Reflection from a plane mirror .....	2-11
2-15	Regular reflection .....	2-12
2-16	Irregular or diffuse reflection .....	2-12
2-17	Reflection at optical interfaces .....	2-12
2-18	Reflection from convex mirror, infinitely distant source .....	2-13
2-19	Reflection from concave mirror.....	2-14
2-20	Projection by spherical mirror .....	2-14
2-21	Projection by parabolic mirror .....	2-15
2-22	Path of beam of light through sheet of glass .....	2-15
2-23	Effects of refraction .....	2-16
2-24	Terms used with reference to reflected light .....	2-17
2-25	Index of refraction.....	2-18
2-26	Atmospheric refraction bends sun rays.....	2-19
2-27	Sun below horizon seen by reflected light.....	2-19
2-28	Path of light ray through prism .....	2-20
2-29	Deviation of rays by two prisms, base to base .....	2-21
2-30	Deviation of rays by convergent lens .....	2-21
2-31	Paths of rays of light through convergent lens .....	2-22
2-32	Law of refraction applied to lens .....	2-22
2-33	Deviation of rays by two prisms, apex to apex .....	2-23
2-34	Deviation of rays by divergent lens .....	2-23
2-35	Angles of light rays from an underwater source .....	2-24
2-36	Total internal reflection in 90 degree prism .....	2-25
2-37	Virtual image reflected by plane mirror .....	2-26
2-38	Real image formed on ground glass of camera .....	2-26
2-39	Letter F as reflected or refracted by optical elements .....	2-27
2-40	Reflection of point of light in mirror .....	2-28
2-41	Reflection of letter F in mirror .....	2-29
2-42	Image transmission by mirrors.....	2-30
2-43	Image transmission by prism .....	2-30
2-44	Focal lengths of convergent lens .....	2-31
2-45	Optical center of the lens .....	2-31
2-46	Focal length of divergent lens .....	2-32
2-47	Image formed by convergent lens.....	2-33
2-48	Magnification by reading glass-object within focal length .....	2-35
2-49	Effect of parallel rays on divergent lens .....	2-36
2-50	Reduction by divergent (negative) lens.....	2-36
2-51	Dispersion .....	2-38
2-52	Field of view limited by optical possibilities of eyepiece .....	2-39
2-53	Comparison of light entering eye with 2-power telescope .....	2-40
2-54	Exit pupil.....	2-41
2-55	Eye distance .....	2-41
2-56	Spherical aberration of convergent lens.....	2-43
2-57	Spherical aberration of divergent lens.....	2-43
2-58	Spherical aberration reduced.....	2-44
2-59	Effect of compound lens on spherical aberration .....	2-44
2-60	Cause of chromatic aberration in lens.....	2-45
2-61	Correction of chromatic aberration of lens .....	2-45
2-62	Correction of chromatic aberration of prism .....	2-46

## LIST OF ILLUSTRATIONS-Continued

Figure	Title	Page
2-63	Proper refraction of light .....	2-47
2-64	Astigmatic refraction of light .....	2-48
2-65	Formation of coma, greatly magnified.....	2-49
2-66	Appearance of coma, greatly magnified.....	2-49
2-67	Barrel-shaped (A and B) and hourglass (C and D) distortion .....	2-50
2-68	Hourglass distortion in magnification by reading glass.....	2-51
2-69	Curvature of image .....	2-52
2-70	Diffraction pattern, greatly magnified .....	2-54
2-71	Newton's rings.....	2-54
2-72	Parallax .....	2-56
3-1	Comparison of eye and camera.....	3-1
3-2	Cross section of eyeball.....	3-2
3-3	Action of iris compared with camera diaphragm .....	3-4
3-4	Suspension and action of crystalline lens .....	3-5
3-5	Cones and rods of retina .....	3-6
3-6	Field of view of the eyes .....	3-8
3-7	Cube as seen by left eye, right eye, and both eyes.....	3-10
3-8	Judging distance.....	3-12
3-9	Angular discernible difference.....	3-13
3-10	Nearsightedness (myopia).....	3-14
3-11	Farsightedness (hypermetropia) .....	3-15
3-12	Visual Limitations .....	3-16
4-1	Types of simple lenses .....	4-2
4-2	Comparative focal lengths of elements in compound lens .....	4-3
4-3	Types of objectives.....	4-4
4-4	Typical light paths through field lens and eyelens of eyepiece.....	4-5
4-5	Kellner and ramsden eyepieces.....	4-6
4-6	Huygenian and symmetrical eyepieces.....	4-8
4-7	Erfle and orthoscopic eyepieces .....	4-10
4-8	French plossl, and variable magnification eyepieces .....	4-11
4-9	Porro prism system .....	4-12
4-10	Abbe system.....	4-12
4-11	Amici or roof-angle prism.....	4-13
4-12	Rhomboidal prism.....	4-13
4-13	Rotating prisms .....	4-15
4-14	Pentaprism (diagrams show effect obtained with mirrors).....	4-17
4-15	Triple mirror prism .....	4-18
4-16	Double right-angle Abbe prism .....	4-19
4-17	Rotation of wedge changes direction of path of light.....	4-19
4-18	Extent of displacement of light may be changed by movement of wedge .....	4-20
4-19	Principles of rotating measuring wedges .....	4-21
4-20	Lens erection systems.....	4-22
4-21	Erecting system using two double right-angle abbe prisms.....	4-23
4-22	Optical system of panoramic telescope .....	4-24
4-23	Image rotation in dove prism (end view) .....	4-25
4-24	Representative types of reticles.....	4-26
4-25	Representative types of reticle patterns.....	4-27
4-26	Diaphragm (stop)location.....	4-28
4-27	Types of ray filter mountings.....	4-29
4-28	Principles of polarization of light .....	4-30
4-29	Instrument light for panoramic telescope .....	4-30
4-30	Instrument light for BC periscope.....	4-31
4-31	Light ray striking uncoated surface .....	4-32
4-32	Light ray striking coated surface (coating one-half wavelength in thickness).....	4-33
4-33	Light ray striking coated surface (coating one-quarter wavelength in thickness).....	4-33
4-34	Low-reflectance coating.....	4-34
4-35	Lens cell, separators, lenses and retaining ring .....	4-35
4-36	Eccentric objective mounting .....	4-36
4-37	Sunshade and objective cap.....	4-36
4-38	Diopter scale .....	4-37
5-1	Simple magnifier-object at principal focus.....	5-1
5-2	Simple magnifier-object with focal length $o$ .....	5-1

## LIST OF ILLUSTRATIONS-Continued

Figure	Title	Page
5-3	Simple compound microscope.....	5-2
5-4	Objective lens.....	5-3
5-5	Keplerian system.....	5-3
5-6	Refracting astronomical telescope.....	5-3
5-7	Concave mirror.....	5-3
5-8	Reflecting astronomical telescope.....	5-4
5-9	Terrestrial telescope-simple form.....	5-4
5-10	Symmetrical erectors.....	5-5
5-11	Simple erector.....	5-5
5-12	Asymmetrical erectors.....	5-5
5-13	Galilean system.....	5-7
5-14	Relation of elements in galilean telescope (zero Diopter setting).....	5-7
5-15	Objective diameter limits field in galilean system.....	5-8
5-16	Function of collective lens.....	5-9
5-17	Function of eyepiece.....	5-9
5-18	Function of field lens in eyepiece.....	5-10
5-19	Zero Diopter setting.....	5-10
5-20	Minus setting for shortsighted eye.....	5-10
5-21	Plus setting for farsighted eye.....	5-10
5-22	Dioptometer.....	5-11
5-23	Reticle location.....	5-12
5-24	Entrance and exit pupils.....	5-13
5-25	Exit pupil-virtual image of objective.....	5-14
5-26	Ramsden dynameter.....	5-14
5-27	Field limit.....	5-15
5-28	Linear true field.....	5-15
5-29	Eye-relief-symmetrical erectors with real images at focal points of erectors and image 0 of objective between erectors.....	5-16
5-30	Eye relief-objective image outside erectors.....	5-16
5-31	Eye relief-collective lens in system.....	5-16
5-32	Angular limit of resolution.....	5-17
6-1	Gas laser.....	6-1
6-2	Solid-state red lasers.....	6-2
7-1	Photoconductive detector.....	7-2
7-2	Bolometer circuit.....	7-3
8-1	Telescope (rifle)--Assembled view, reticle pattern.....	8-1
8-2	Telescope (sniper's sighting device)--assembled view.....	8-2
8-3	Observation telescope--assembled view with tripod.....	8-2
8-4	Observation telescope-optical elements and optical diagram.....	8-3
8-5	Articulated telescope-optical system diagram.....	8-3
8-6	Articulated telescope (tank)--assembled view.....	8-4
8-7	Articulated telescope (self propelled vehicle) --assembled view.....	8-4
8-8	Schematic diagram of elbow telescope.....	8-5
8-9	Elbow telescope (howitzer) -assembled view, reticle patterns.....	8-6
8-10	Elbow telescope (sight units)--assembled view, reticle pattern.....	8-7
8-11	Elbow telescope (towed howitzer)--assembled view.....	8-7
8-12	Elbow telescope (self propelled howitzer)--assembled view.....	8-8
8-13	Panoramic telescope (towed howitzer)-assembled view, optical elements, and optical diagram.....	8-9
8-14	Panoramic telescope (self propelled howitzer) --assembled view.....	8-10
8-15	Periscope (tank observation)--assembled view, optical elements and diagram of principle of operation.....	8-11
8-16	Optical diagram and optical elements of periscope.....	8-12
8-17	Periscope (self propelled vehicle)--assembled view.....	8-13
8-18	Periscope (tank)--assembled view.....	8-13
8-19	Periscope (tank-diagram of optical system.....	8-14
8-20	Periscope (infrared) -assembled view.....	8-15
8-21	Binocular (general use)-assembled view, optical elements, and optical diagram.....	8-17
8-22	Battery commander's periscope-assembled view, reticle pattern.....	8-19
8-23	Optical system schematic.....	8-20
8-24	Fundamental triangle of range finder.....	8-21
8-25	Range finder, tank M17A1 and M17C (typical coincidence type).....	8-22
8-26	Range finder, reticle patterns.....	8-25
8-27	Collimator sight-optical system and optical diagram.....	8-27
8-28	Reflex sight.....	8-28
8-29	Aiming circle.....	8-29

LIST OF ILLUSTRATIONS-Continued

Figure	Title	Page
8-30	Laser range finder .....	8-30
8-31	Fire control subsystem .....	8-32
10-1	Artillery mil-degree conversion chart.....	10-2
10-2	Metric unit-inch conversion table .....	10-6
B-1	Absorption-selective transmission .....	B-1
B-2	Angle of azimuth.....	B-2
B-3	Angle of elevation, angle of site, and quadrant angle.....	B-3
B-4	Apertures.....	B-4
B-5	Astigmatism.....	B-5
B-6	Axis of bore and boresights-boresighting.....	B-6
B-7	Burnishing .....	B-7
B-8	Center of curvature.....	B-7
B-9	Conjugate focal points (conjugate foci).....	B-9
B-10	Converging lenses.....	B-9
B-11	Diverging lenses .....	B-11
B-12	Drift.....	B-12
B-13	Lens erecting system.....	B-13
B-14	Eyelens and field of eyepiece .....	B-14
B-15	Focal length of lens and mirror .....	B-15
B-16	Real image produced by converging lens .....	B-17
B-17	Virtual image produced by diverging lens .....	B-17
B-18	Index of refraction.....	B-18
B-19	Optical system of erecting telescope .....	B-19
B-20	Linear field.....	B-20
B-21	Magnifying power.....	B-21
B-22	Nearsightedness (myopia).....	B-22
B-23	Normal and oblique .....	B-22
B-24	Porro prism.....	B-25
B-25	Prism.....	B-25
B-26	Protractor.....	B-26
B-27	Reticle patterns superimposed on image of object .....	B-27
B-28	Right angle prism.....	B-28
B-29	Waves and wave fronts .....	B-30

## CHAPTER 1

### INTRODUCTION

---

**1-1. Purpose.** This manual is published primarily for the information and guidance of Army maintenance and

using personnel and others who must be familiar with the functioning of fire control instruments (fig 1-1).



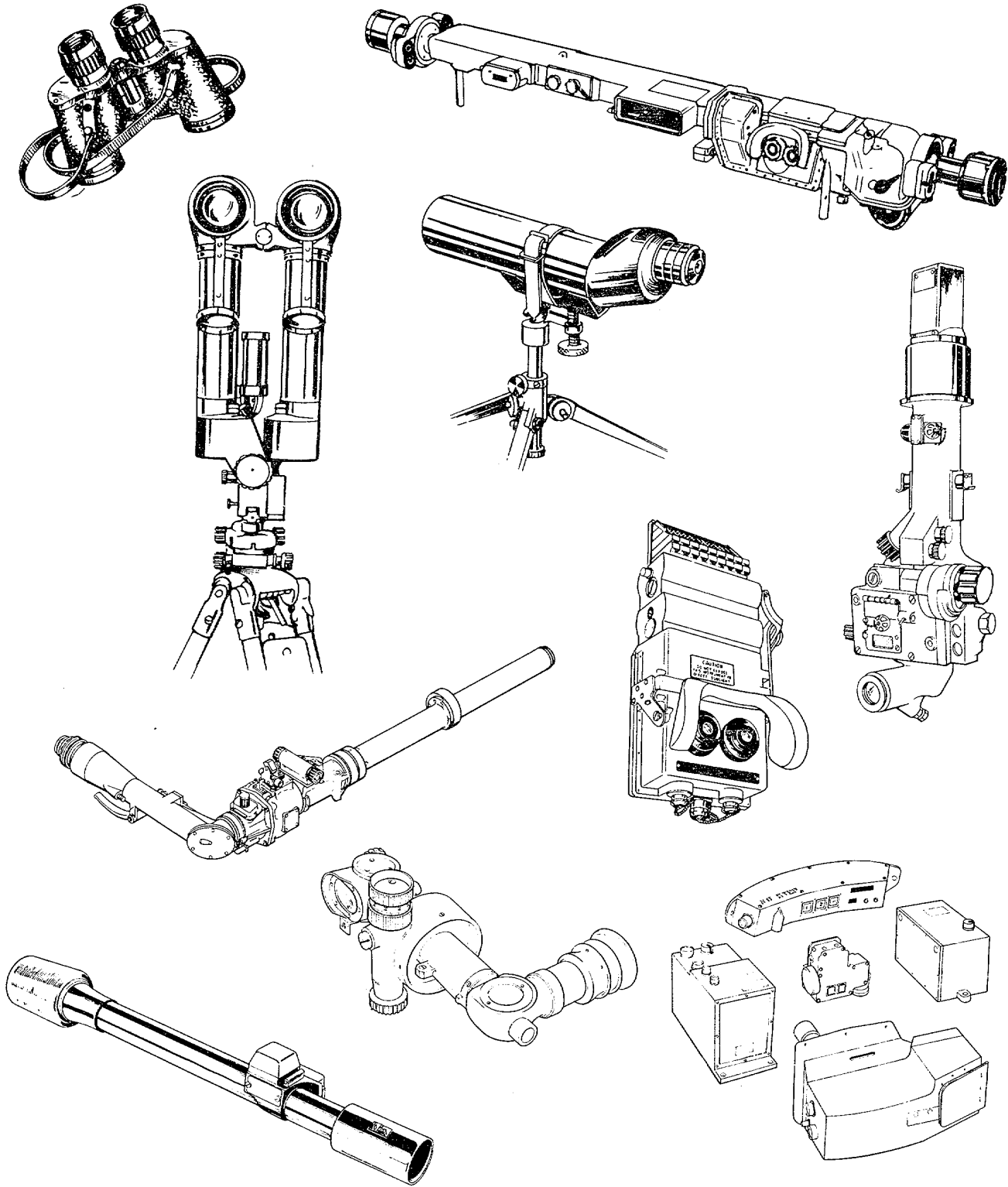

AR910006

Figure 1-1. Military application of optics.

**1-2. Scope**

a. This manual covers the basic principles of optical theory necessary to understand the operation of fire control instruments. It contains sufficient descriptive matter and illustrations to provide a general knowledge of the principles upon which the design and construction of military optical instruments are based. A background in physics and mathematics, though helpful, is not

essential, as the use of those subjects in this text is on a simple level.

b. The glossary contains definitions of specialized terms and unusual words used in this manual. A list of current references appears in this appendix.

c. The material presented herein is applicable without modification, to both nuclear and non-nuclear warfare.

## CHAPTER 2

## PROPERTIES OF LIGHT

## Section I. LIGHT

**2-1. Theories and Known Facts About Light.**

a. *General.* The true nature of light and the manner in which it travels have fascinated scientific investigators for centuries. Many theories have been advanced to explain why light behaves as it does. Later discoveries have proved some of these theories unsound. This manual cannot attempt to cover all the aspects of light nor is this knowledge essential to the study of the laws of optics as they apply to fire control equipment. Therefore, only a short summary of the various theories of light is given.

(1) *Ancient Greek theory.* The earliest known speculations as to the nature of light were those of the ancient Greeks. They believed that light was generated by streams of particles which were ejected from the human eye. This theory could not persist because it could not explain why one could not see as well at night as by day.

(2) *Newton.* The first modern theory was that of Sir Isaac Newton (1643-1727). This, the corpuscular theory, assumed light to be a flight of material particles originating at the light source. Newton believed that light rays moved at tremendous velocity in a state of near vibration and could pass through space, air, and transparent objects. This theory agreed with the property of light to move only in a straight line, in a medium of constant optical density, but failed to explain other phases of light behavior. Newton stumbled on light interference in his discovery of Newton's Rings (para 2-44) but did not realize their significance.

(3) *Huygens.* In Newton's time, Christian Huygens (1629-1695) attempted to show that the laws of reflection and refraction of light could be explained by his theory of wave motion of light. While this theory seemed the logical explanation for some phases of light behavior, it was not accepted for many years because a means was lacking by which to transmit the waves. Huygens proposed that a medium, which he called "ether," be accepted as existing to serve light rays as water does the familiar waves of water. He assumed this medium to occupy all space, even that already occupied by matter.

(4) *Young and Fresnel.* Experiments made about 50 years later by Thomas Young (1773-1829),

Fresnel (1788-1827), and others supported the wave theory and the rival corpuscular theory was virtually abandoned. These scientists offered their measurement of light waves as proof. They accepted the "ether" theory and assumed light to be waves of energy transmitted by an elastic medium ether.

(5) *Maxwell, Boltzmann, and Hertz.* Light and electricity were similar in radiation and speed was proved the experiments of Maxwell (1831-1879), Boltzmann (1844-1906), and Hertz (1857-1894). From these experiments was developed the Electromagnetic Theory. These experiments produced alternating electric currents of short wavelengths that were unquestionably of electromagnetic origin and had all the properties of light waves. The Maxwell theory contended that energy was given off continuously by the radiating body.

(6) *Planck.* For a time it was thought that the puzzle of light had been definitely solved but, in 1900, Max Planck refuted the Maxwell theory that the energy radiated by an ideal radiating body was given off continuously. He contended that the radiating body contained a large number of tiny oscillators, possibly due to the electrical action of the atoms of the body. The energy radiated could be high frequency (para 2-3b) and with high energy value, all possible frequencies being represented. The higher the temperature of the radiating body the shorter is the wave length (para 2-3a) of most energetic radiation. In order to account for the manner in which the radiation from a warm black body is distributed among the different wave lengths, Planck found an equation to fit the experimental curves, and then only on the very novel assumption that energy is radiated in very small particles which, while invisible, were grains of energy just as much as grains of sand. He called these units quanta and his theory the Quantum Theory. The elementary unit or quanta for any given wave length is equal to  $hn$ , where  $n$  is frequency of the emitted radiation and  $h$  is a constant known as Planck's constant. Quanta set free were assumed to move from the source in waves.

(7) *Einstein.* A few years later, Albert Einstein backed up in Planck and contended that

the light quanta when emitted retained their identity as individual packets of energy.

(8) *Millikan and Compton.* Still later, R.A. Millikan's very accurate measurements proved that the energy due to motion (called "kinetic energy") of elemental units of light (called "photons") behaved as assumed by the Quantum Theory. Later proof was given by A.H. Compton in 1921 in determining the motion of a single electron and a photon before and after collision of these bodies. He found that both have kinetic energy and a momentum and that they behave like material bodies. This was somewhat a return to the old corpuscular theory.

(9) *Summary.* The present standpoint of physicists on the nature of light is that it appears to be dualistic, both particle and wavelike. It is assumed that light and electricity have much in common. It is presently accepted that the energy associated with a light beam is transmitted as small particle-like packets-*photons*, originally called *quanta* (para 2-1a (6) which may be described in terms of associated waves, but, which are best measured relying solely on their particle-like nature. The simple wave analogy is only a very rough approximation. However, the phenomena of light propagation may be best explained in terms of wave theory. The wave theory will be used in the remainder of this manual.

b. *Known Facts.* All forms of light obey the same general laws. Light travels in waves in straight lines and at a definite and constant speed, provided it travels in a

medium or substance of constant optical density. Upon striking a different medium, light either will bounce back (be reflected) or it will enter the medium. Upon entering a transparent medium, its speed will be slowed down if the medium is more dense or increased if the medium is less dense. Some substances of medium density have abnormal optical properties and for this reason "optically dense" would be a better term. If it strikes the medium at an angle, its course will be bent (refracted) upon entering the medium. Upon striking all material mediums, more or less of the light is absorbed.

(1) *Transmission of light energy.* Visible light is one of many forms of radiant energy which is transmitted in waves. The means by which the waves carry the energy can be illustrated in a simple manner. Secure one end of a rope to some object. Hold the other end of the rope, stretch it fairly taut, and shake it. A wave motion (wave pulse) will pass along the rope from the end that is held to the end that is secured (fig 2-1). If the end of the rope is continually shaken, a series of waves (wave train) will pass along the rope (fig. 2-2). It will be noted that the different parts of the rope (the medium) vibrate successively, each bending back and forth about its own position. The disturbance travels but the medium does not. Only the energy is carried along the rope. Now imagine that the light source is a vibrating ball from which a countless number of threads extend in all directions. As the ball vibrates, successive waves are transmitted out along the threads in all directions. In a similar manner, light radiates from its source.

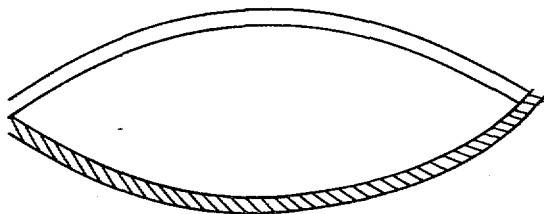

AR910007

Figure 2-1. Wave carrying energy along rope.

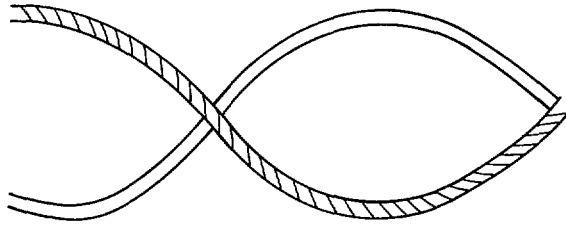

AR910008

*Figure 2-2. Wave train passing along rope.*

(2) *Electromagnetic spectrum.* Heat and radio waves, light waves, ultraviolet and infrared rays, X-rays, and cosmic rays are forms of radiant energy of different wavelengths and frequencies. Together, they form what is known as the electromagnetic spectrum (fig 2-3). The visible light portion of the electromagnetic spectrum consists of wavelengths from 0.00038 to 0.00066 millimeter. The different wavelengths represent different

colors of light. Practically all light is made up of many colors, each color having its distinctive wavelength and frequency. In as much as light of each color reacts in a slightly different manner when passed through different mediums, provision must be made in optical elements to control the action of light of various colors.

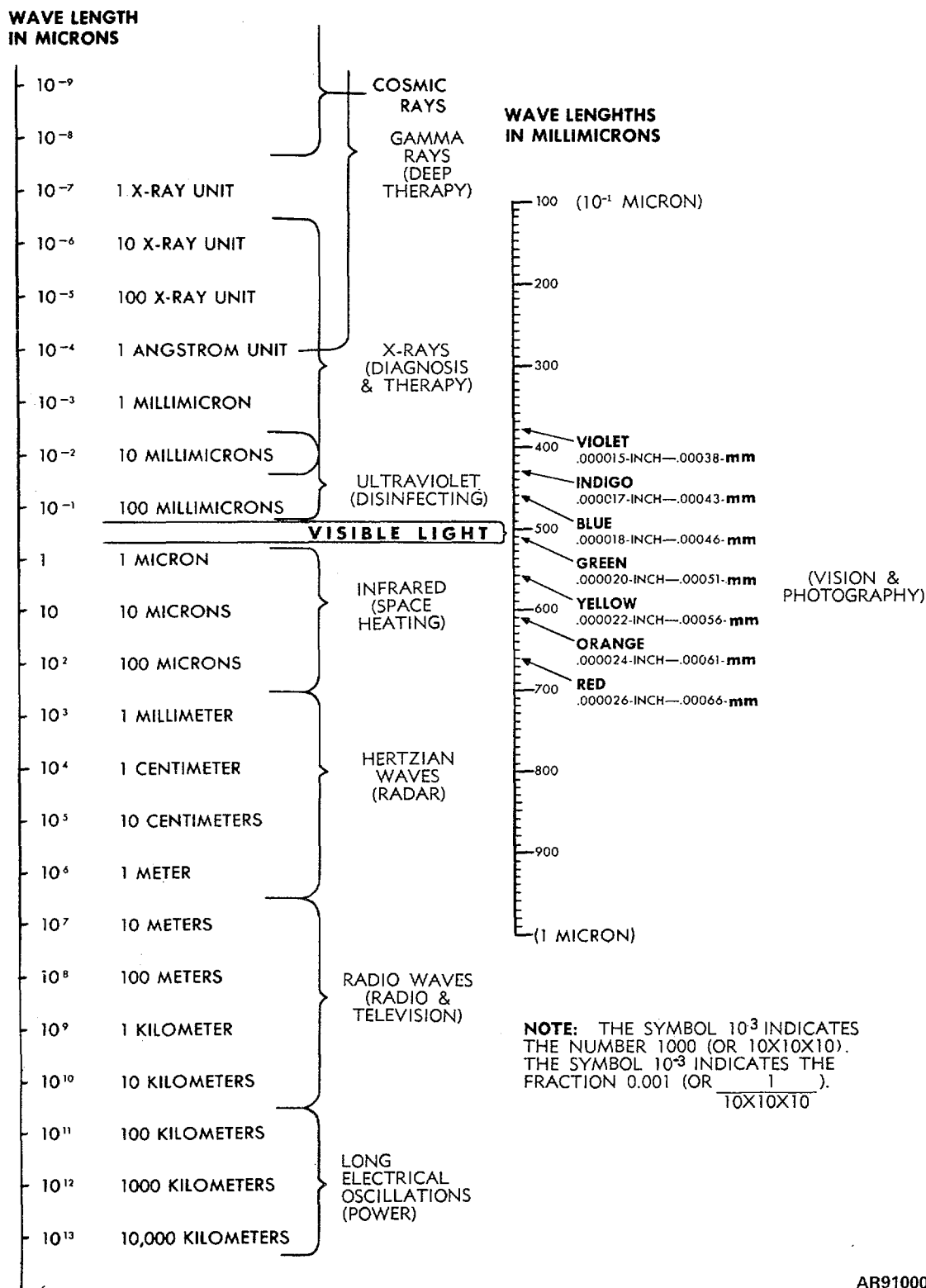

AR910009

Figure 2-3. Electromagnetic spectrum.

(3) *Light rays.* In considering visible light, assume that it starts from a luminous point and travels outwardly in all directions in waves through a medium of constant density to form a sphere of which the luminous point is the center (fig 2-4). The direction in which the light is traveling is along the radii of the sphere of light (fig 2-5) at right angles to the fronts of the waves. Light traveling along these radii is termed light rays.

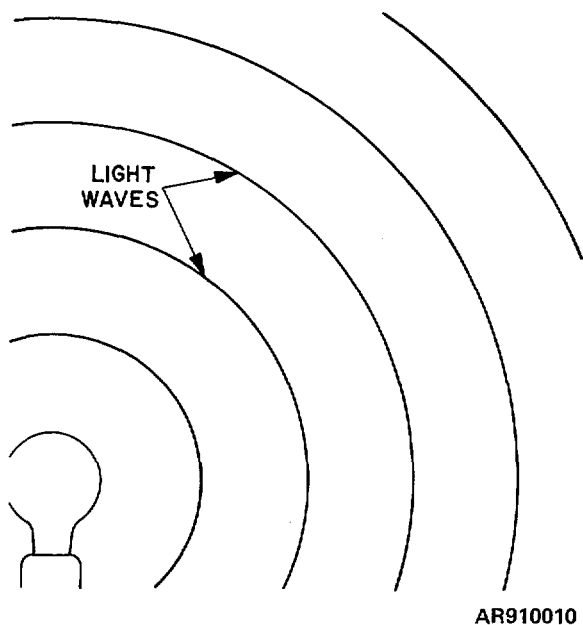

Figure 2-4. Light sources send waves in all directions.

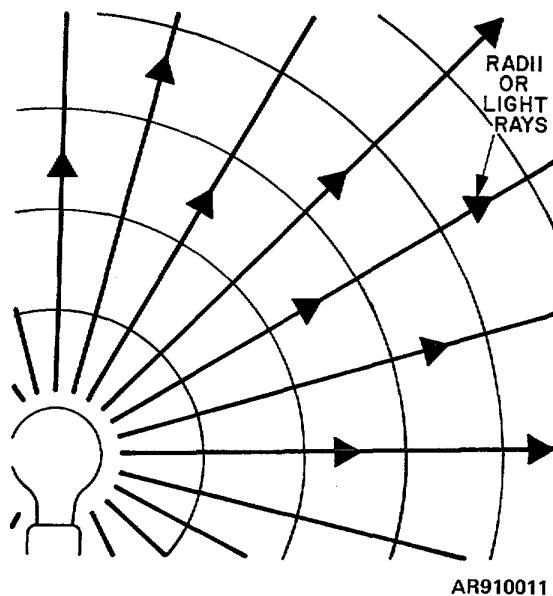
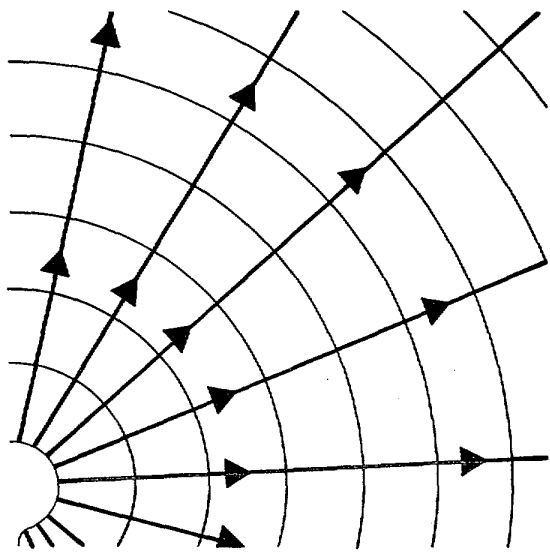

Figure 2-5. Light travels in direction of radii of waves.

(4) *Light rays from distant source.* The wave front radiating from a light source is curved when it is near the source (fig 2-6) and the radii of the waves diverge or spread. The wave front becomes less and less curved as the waves move outwardly, eventually becoming almost straight (fig 2-7), and the radii of waves from a distant source are virtually parallel.

Figure 2-7. Waves and radii from distant light source.



AR910012

Figure 2-6. Waves and radii from nearby light source.

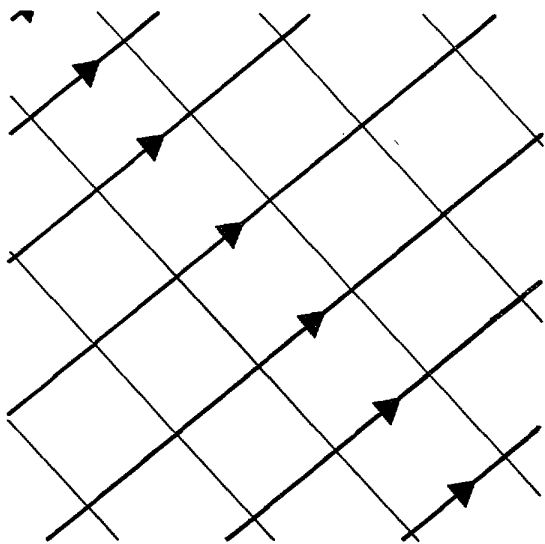

AR910013

(5) *Principle of reversibility of light paths.* If a single narrow beam of parallel light is reflected or refracted in any combination through a number of optical elements, it will retrace its path through the elements if the light were to enter the optical system from the other end. This is true no matter how many reflections and refractions the light has undergone.

(6) *Color.* Most substances reflect light selectively. Certain wavelengths (colors) are reflected, while others are absorbed. The color of an object is the one which is reflected. A colored transparent medium (filter) transmits light selectively, absorbing all rays not transmitted.

(7) *Biological effects.* Infrared light is not very effective on living tissues except to produce heat. Visible light is beneficial in its effects. Shorter waves may produce serious burns, but possess marked bactericidal properties and are used for sterilizing milk and other materials. In general, the shorter the waves the more violent are they in their effects on living tissues.

## 2-2. Speed of Light

a. The speed of light (fig 2-8) is an important factor in the study of the physical nature of light. The lengths of all waves in the electromagnetic spectrum (fig 2-3) are logically connected to corresponding frequencies and to the speed of light (para 2-3). The difference in the speed of light through air, glass, and other substances accounts for the bending of light rays or refraction.



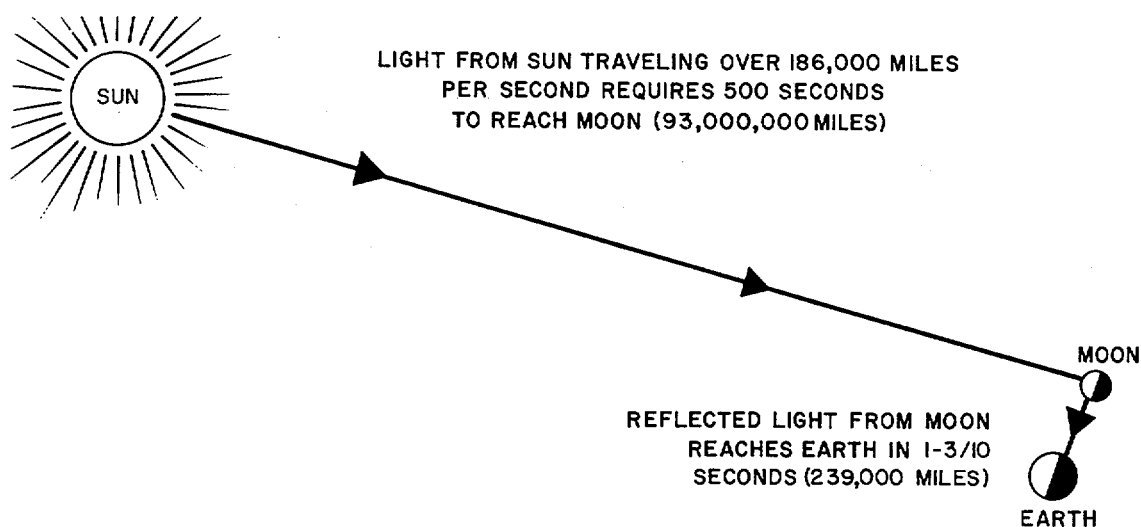

AR910014

Figure 2-8. Speed of light

b. Light travels so fast that it was a long time before its speed could be measured. Galileo Galilei (1564-1642) tried to measure light velocity by means of blinking lanterns on widely distant hilltops but, as the speed was too great to be measured by this method, the velocity of light was presumed to be infinite.

c. Thirty-four years after Galileo's death, Olaus Roemer (1644-1710) determined the approximate speed of light by astronomical means based on observations which showed the amount of time required for the light of the planet Jupiter to cross the orbit of the earth.

d. It was nearly 200 years more before scientists were able to measure a speed so great as that of light by laboratory methods. In 1849, Fizeau (1819-1896) measured the velocity of light, using intermittent flashes of light sent out by a source equipped with a swiftly moving toothed wheel and reflected back to the observer. Other methods, employing the reflections from rotating mirrors and prisms, have since been used

to establish the speed of light to an exactness beyond that required for practical usage.

e. The speed of light is accepted as 186, 330 miles per second. This is the figure used in computations involving the speed of light. The speed of light obtained by the important methods of the past 70 years ranges from 186, 410 to 186, 726 miles per second.

### 2-3. Wavelength and Frequency

a. *Wavelength.* The wavelength is the distance from the crest or top of one wave to the crest of the next, or from any point on one wave to the corresponding point, in the same phase on the next wave (fig 2-9). The velocity of all forms of electromagnetic waves in vacuum is the same, that is, the speed of light is approximately 186, 000 miles per second. The wavelengths, however, vary greatly (fig 2-3).

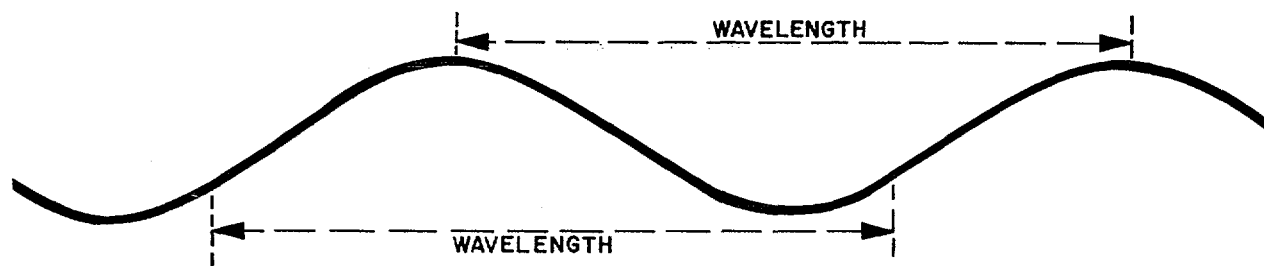

AR910015

Figure 2-9. Wavelength

b. *Frequency.* The frequency is the number of waves occurring per second. It is determined by dividing the speed of light by the wavelength. It is the number of waves passing a given point in 1 second (fig 2-10).

$$\text{Frequency} = \frac{\text{Velocity}}{\text{Wavelength}}$$

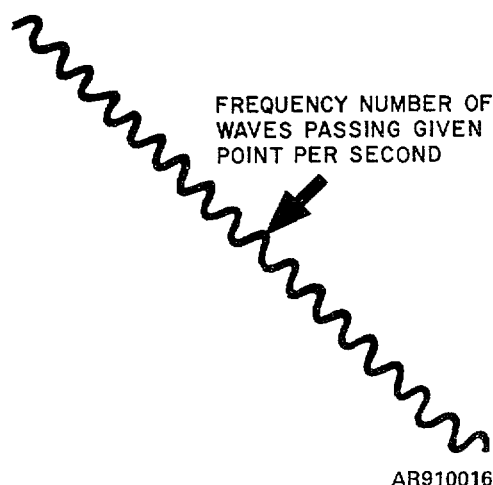

AR910016

Figure 2-10. Frequency

c. *Special Units of Measurement Employed in Measuring Wavelengths.* Wavelengths of electromagnetic waves range from many miles long to those measured in trillionths of an inch. The measurements cover such a wide range and the shorter wavelengths are so minute that special units of measurements have been provided to avoid long decimal fractions of millimeters or inches.

(1) The first of the special units of measurement is the *micron*, which is abbreviated to  $\mu$ , the Greek letter "mu". It represents one one-millionth of a meter or one one-thousandth of a millimeter. The next is variously called the *milli-micron* and *micro-millimeter*. It is abbreviated to  $m\mu$  and represents one one-thousandth of a micron. Finally, the *micro-micron* is abbreviated to  $go$ . It represents one one-millionth of a micron.

(2) Another important measurement is the Angstrom unit (AU) which is one-tenth of a milli-micron or one ten-millionth of a millimeter. Even Angstrom units are inconveniently long in measuring the shortest electromagnetic waves so the X-ray unit (XU) is used for this purpose. It is one one-thousandth of an Angstrom unit.

**2-4. Light Rays and Other Symbols Used in the Diagrams.**

a. Every point on a luminous body or an illuminated object sends out a constant succession of wave fronts in all directions. The action of light in passing through a lens, for example, might be as shown in A, figure 2-11. But for simplicity, light will be indicated in this manual by one, two, or more representative "light rays." These "light rays" are shown as lines with arrowheads indicating the direction of travel and are shown as in B, figure 2-11. Wherever possible light will be indicated as coming from the left side of an illustration.

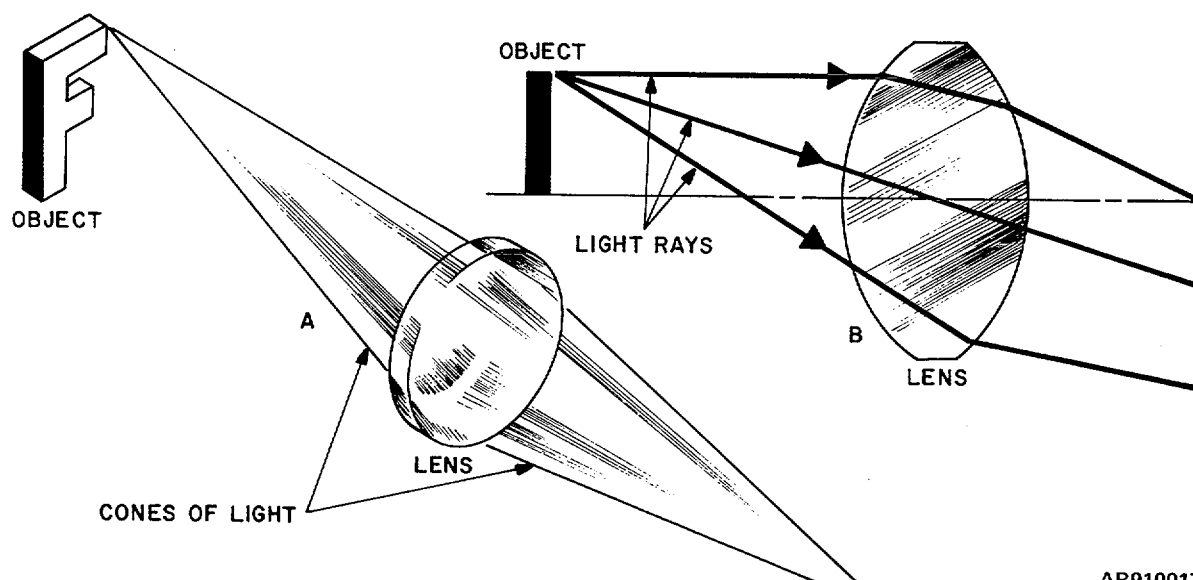

AR910017

Figure 2-11. Symbols and types of illustrations used in this manual.

b. Single rays of light do not exist. The term "light ray" is used throughout this manual for the sake of clarity and convenience to indicate the direction of travel of light.

c. In studying the diagrams, it must be remembered that printed illustrations have only height and width (b, fig 2-11) while everything, including light, has three dimensions: height, width, and depth (or length). The reader's imagination must be employed to give the illustration depth. Thus, for example, where two light rays are used to indicate the course of light

from a luminous or illuminated point, these light rays indicate a solid cone of light from that point (A, fig 2-11). In certain of the illustrations, an attempt has been made to simulate height, width, and depth by preparing the diagrams to appear as though viewed from an angle (A, fig 2-11).

d. The letter F is used as the object in a great many of the diagrams because it shows quickly whether the image of this letter or object is upright, inverted, or reverted.

## Section II. REFLECTION

### 2-5. Reflection From a Plane Mirror.

a. A plane mirror is a flat polished surface used to reflect light. If a beam of light is permitted to enter a darkened room and a plane mirror is held so that the beam will strike the mirror, the beam will be reflected. By shifting the mirror, the beam can be reflected to almost any part of the room.

b. If the mirror is shifted so that it is exactly at right angles (normal) to the beam, the reflected beam will be

directed back along the path of the incoming beam (A, fig 2-12). If the mirror is shifted to an angle from this position, the reflected beam will be shifted at an angle from the incoming beam that is twice as great as the angle by which the mirror is shifted (B, fig 2-12). For example, if the mirror is held at angle of  $45^\circ$  to the incoming beam, the reflected beam will be projected at an angle of  $90^\circ$  to the incoming beam.

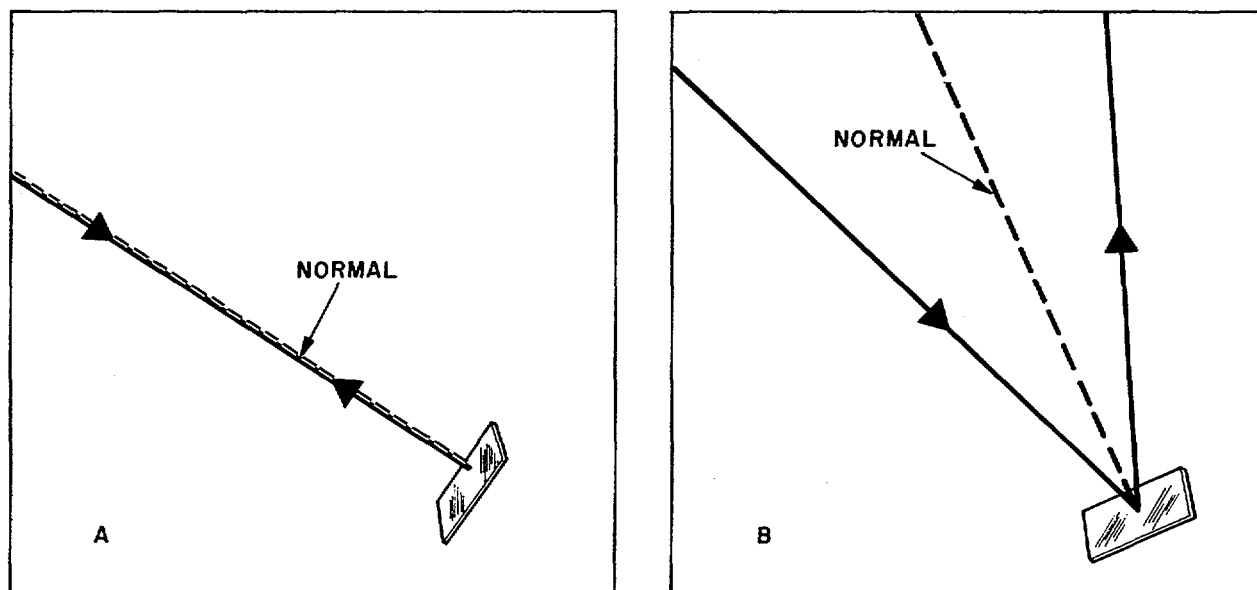

AR910018

Figure 2-12. Beam of light reflecting back.

c. These simple experiments illustrate one of the dependable forms of action of light. Light can be reflected precisely to the point where it is required because any kind of light, on being reflected by a smooth, polished surface, acts in the same manner. This action of light is put to use in many types of fire-control instruments.

d. The ray of light which strikes the surface is called the incident ray (fig 2-13). The ray which is

reflected is termed the reflected ray. An imaginary line at right angles to the surface is called the normal or perpendicular. The angle between the incident ray and the normal is the angle of incidence, while the angle between the reflected ray and the normal is the angle of reflection.

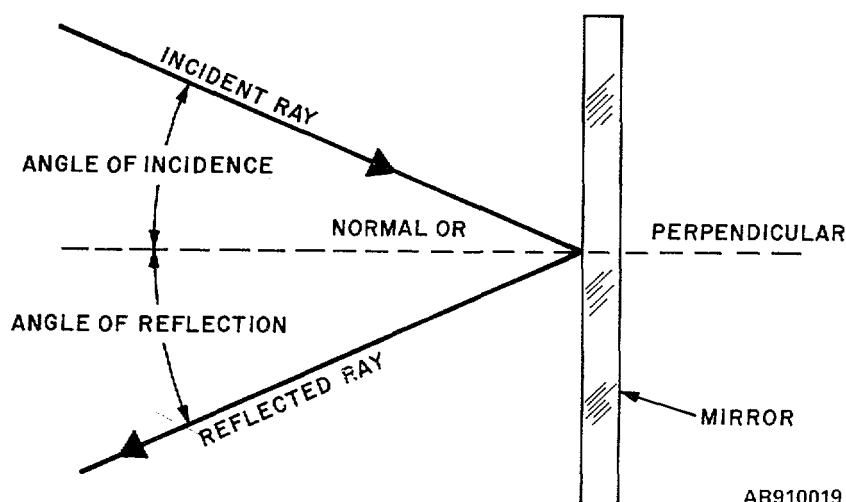

AR910019

Figure 2-13. Terms used with reference to reflected light.

e. The best reflectors are very smooth metal surfaces, some of which may reflect as much as 98 percent of perpendicular light. The glass in a silvered mirror serves only as a very smooth supporting surface and protective window for the silver coating on the back. In front surface aluminized mirrors, the glass serves only as a smooth supporting surface for the aluminum reflecting surface. The resulting aluminum oxide (from the oxidation of the aluminum when exposed to the oxygen in the air) is both colorless and transparent and so does not interfere to any appreciable extent with the passage of light. This type of coating is used on the reflectors in the huge reflecting astronomical telescopes.

**2-6. Law of Reflection**

a. The law of reflection is as follows: The angle of reflection is equal to the angle of incidence and lies on the opposite side of the normal; the incident ray, reflected ray, and normal all lie in the same plane.

b. Diagrams A, B, C, and D in figure 2-14 show light rays incident upon plane mirrors at successively smaller angles. By applying the law of reflection, it can be seen that in all such cases of reflection the angle of reflection can be plotted as long as the angle of incidence is known or vice versa.

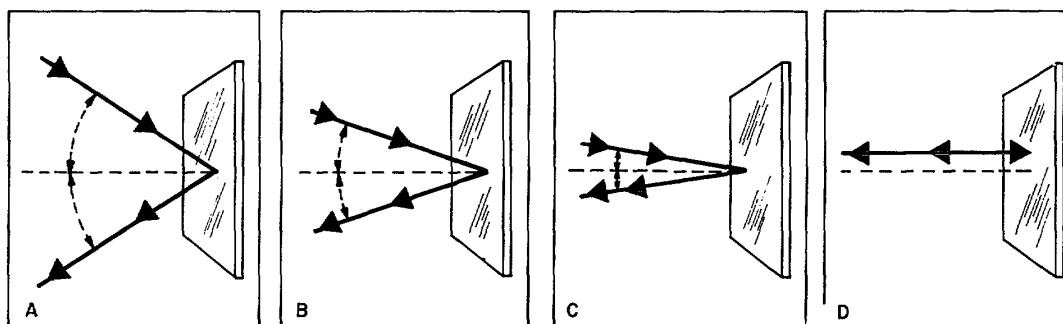

AR910020

Figure 2-14. Reflection from a plane mirror.

**2-7. Types of Reflection.**

a. There are two main types of reflection regular and irregular.

b. Regular reflection occurs when light strikes a smooth surface and is reflected in a concentrated manner (fig 2-15).

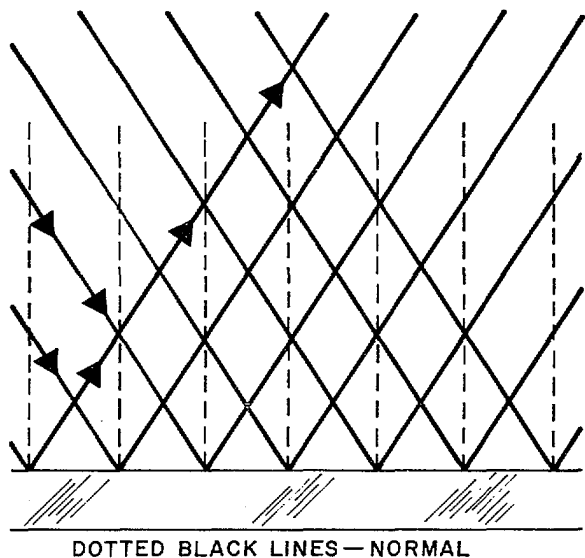

AR910021

Figure 2-15. Regular reflection.

c. If a beam of light strikes a rough surface, such as a sheet of unglazed paper or ground glass, the light is not reflected regularly but is scattered in all directions (fig 2-16). This is called irregular reflection or diffusion.

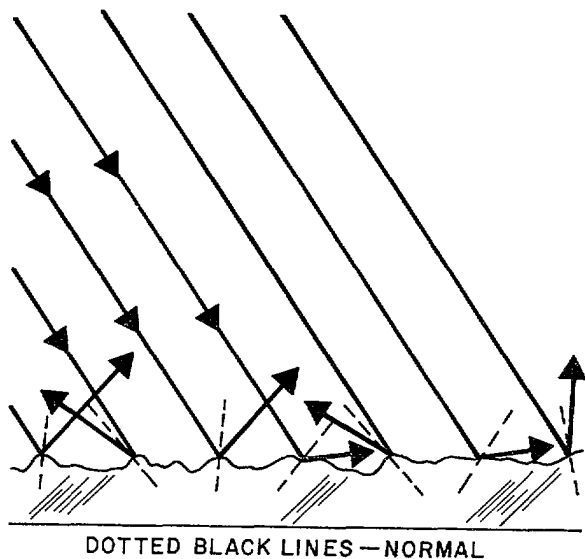

AR910022

Figure 2-16. Irregular or diffuse reflection.

d. The direction in which any single ray of light will be reflected can be plotted by erecting a perpendicular or normal at the point of impact and applying the law of reflection (fig 2-16). Any rough surface can be regarded as an almost infinite number of elementary plane surfaces at each of which the law of reflection holds true.

e. Light is reflected by diffusion or by regular reflection and diffusion from nearly every object which is seen. Because the light falling on such an object is, in part, scattered in all directions, the object is made visible, generally, when viewed from any direction. Skin, fur, and every dull surface reflect light in essentially a diffused manner. The glossy finish of a new automobile or the bright finish of a polished casting reflect light essentially by regular reflection and partially by diffusion.

f. Surfaces of transparent mediums such as optical interfaces also will reflect. The amount of incident light reflected depends upon the angle of incidence. As the angle of incidence increases, so does the amount of reflected light. When light passes through a piece of glass, reflection occurs at both surfaces as in figure 2-17. Approximately 4 percent of the incident light is lost or reflected at the first surface and another 4 percent of the emergent light is lost by reflection at the second surface. Thus, both reflection and refraction (the bending of light) occur at any optical interface. The importance to optical systems is discussed in detail in paragraphs 4-1 through 4-16).

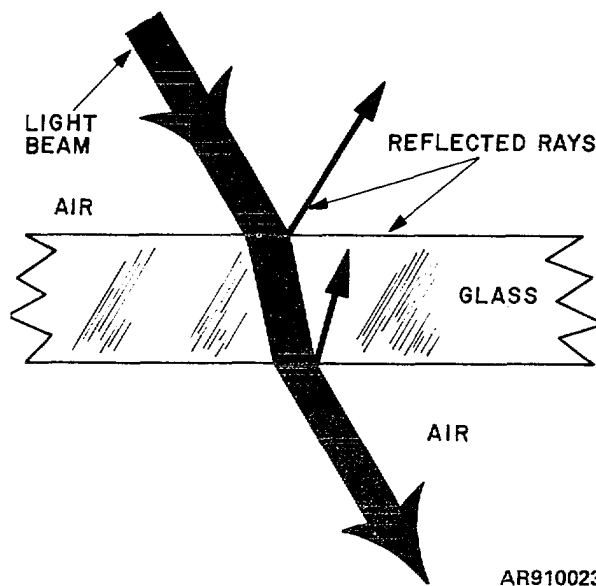

AR910023

Figure 2-17. Reflection at optical interfaces

**2-8. Reflection from Convex Mirror.**

a. The law of reflection holds true for all surfaces whether convex, concave, or plane. The action of various curved surfaces in directing the course of the reflected light will vary according to the amount of curvature of the reflecting surface and the overall effect will be dependent on the distance of the light source from the reflecting surface.

b. Assume that light from a practically infinitely distant source, such as the sun (practically parallel rays), strikes a convex mirror (fig 2-18). It will be found that the

rays will be deflected in a divergent manner. The reason for this can be, determined by plotting the angles of reflection of individual rays in relation to their angles of incidence and the normals for each ray. In this case, the normal for each ray is an imaginary line drawn from the center of curvature of the mirror to the point of incidence of the ray. The angle of reflection will be equal to the angle of incidence for each ray.

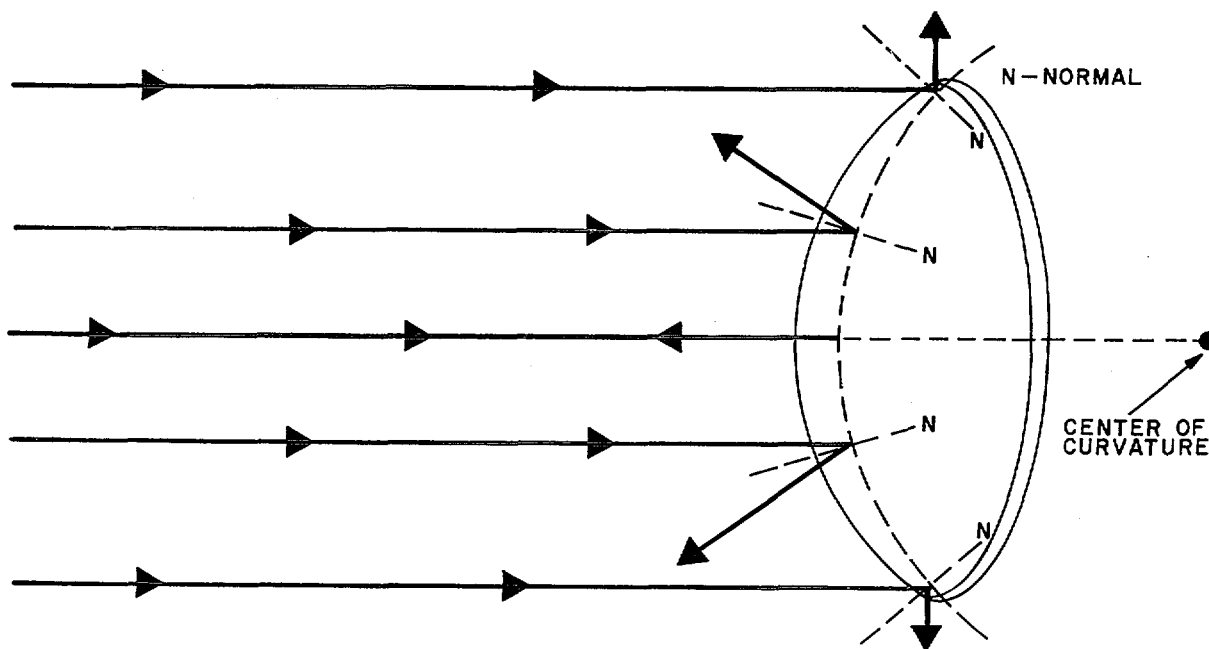

AR910024

Figure 2-18. Reflection from convex mirror, infinitely distant source.

c. If the light source is at a finite distance, or close to the mirror, the rays will be reflected in a divergent manner also. Such rays will be reflected at different angles than would be the case if all of them struck the mirror as parallel rays.

**2-9. Reflection from Concave Mirror.**

a. The law of reflection is again applied to locate the path of the reflected rays when plotting the reflection from a concave mirror. In this instance, the center of curvature of the mirror is in front of the mirror (fig 2-19). Imaginary lines are run from this center to the points of incidence of the incident rays, to indicate the normals of individual rays. When this has been done, the reflected rays can be plotted so that each forms an angle of reflection which will be equal to the angle of incidence of the corresponding ray.

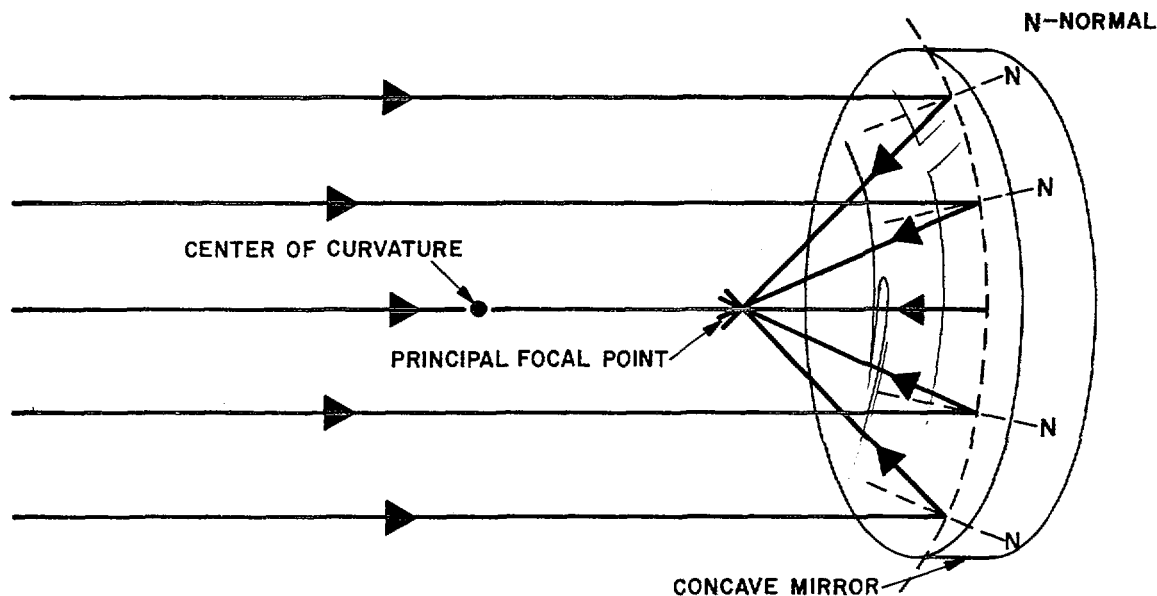

AR910025

Figure 2-19. Reflection from concave mirror.

b. It will be noted that the rays originating from an infinite (distance) source, such as the sun, are converging after reflection and that they intersect very close to a point halfway between the center of curvature and the surface of the mirror. This point is known as the principal focal point of the mirror. This point of principal focus is always one-half of the distance from the center of curvature to the surface of a concave mirror, provided the mirror is a true portion of a sphere. Due to "spherical aberration," the principal focus is a true point only for a small central bundle of rays. After passing through the focal point, the light will diverge.

c. If a very small luminous source is located at the principal point of focus, the rays will be nearly parallel after reflection. This is true only if the curvature is very slight. Actually, the rays will have a slight convergence, especially those which are reflected from near the edges of the mirror (fig 2-20). For this reason, if it is desired to have practically parallel rays after reflection, a parabolic mirror is used.

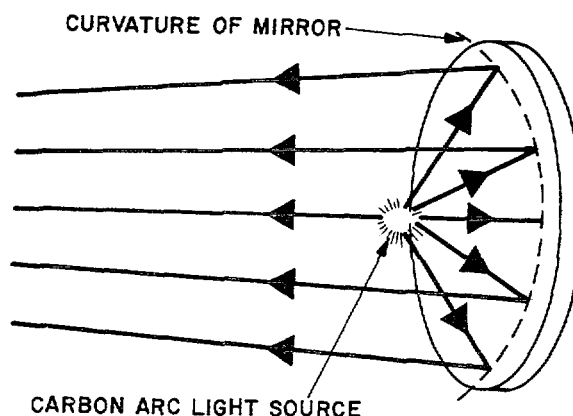

AR910026

Figure 2-20. Projection by spherical mirror.



d. With a parabolic mirror, light rays emanating from an infinitely small source located at the focal point would be parallel after reflection, since this is the principal focal point of the parabolic mirror (fig 2-21). In practice, however, the source of light, which may be a filament or an arc, is located in the principal point of focus and the rays diverge as there cannot be a true point source. All rays falling upon the parabolic mirror, except those which are diffused or scattered, are reflected nearly parallel to each other. This allows a long powerful beam of light to be formed which diverges very slightly.

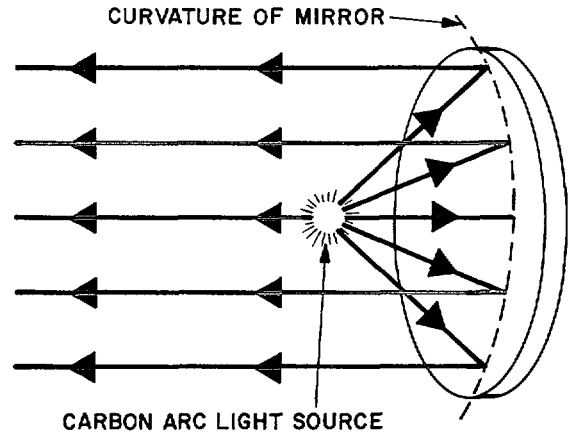

AR910027

Figure 2-21. Projection by parabolic mirror.

**Section III. REFRACTION**

**2-10. Refraction Through a Glass Plate.**

a. What happens when light is refracted can be understood by imagining a beam of light, indicated by a broad "light ray" or "light beam" (fig 2-22), passing in slow motion through a sheet of glass. Both plane

surfaces of this plate are parallel and air contacts both surfaces. The glass and the air are transparent but the glass is optically denser than the air. Light travels approximately one-third slower in glass than in air.

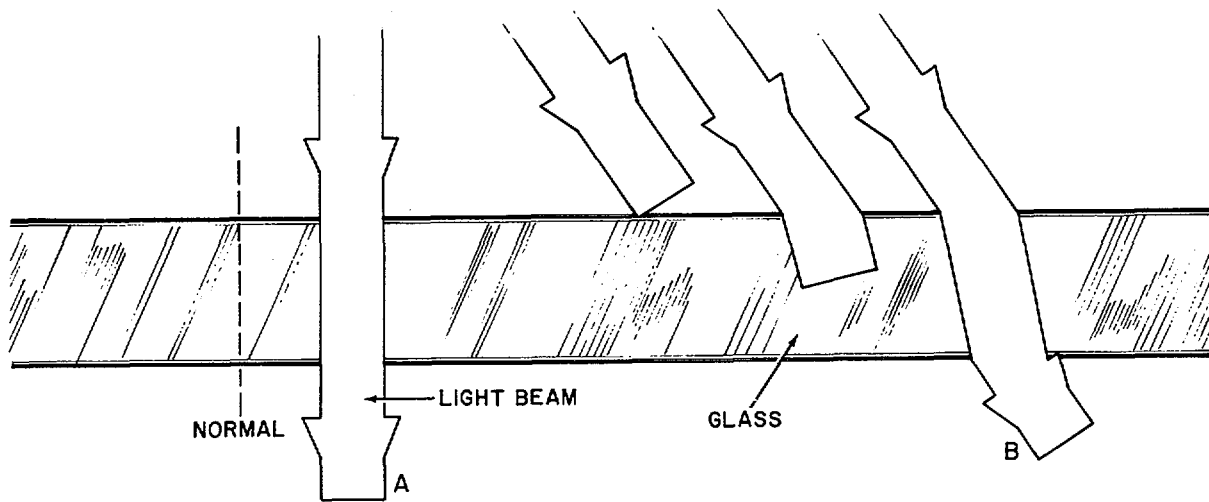

AR910028

Figure 2-22. Path of beam of light through sheet of glass.

b. If the beam strikes the glass directly at right angles (or the normal), the light is not bent or refracted (A, fig 2-22). Its speed is slowed down upon encountering the optically denser medium, but as the entire front strikes the glass at the same instant its path is not deviated but continues through the medium in a straight line. Upon reaching the other surface of the glass, the beam enters the optically lighter medium, air, and resumes its faster speed in air.

c. If this beam of light strikes the glass at an angle, one of the edges of the wave front arrives at the surface an instant before the other edge does and consequently its path through glass is longer, at this point, while entering glass. The edge of the front arriving at the glass first is slowed down upon entering the optically denser medium (B, fig 2-22). When the other edge enters the glass, it is slowed down in the same manner but an instant later, having traveled with greater speed in air, the effect is to swing the entire beam toward the normal. This bending of light is termed refraction.

The light follows its new course in a direct line when the optical density of the medium is constant.

d. Upon leaving the other surface of the glass plate, the light is again refracted or bent (B, fig 2-22). The edge which entered the glass first traverses the glass first. Upon leaving the optically denser medium and entering the optically lighter medium (air), its path is deviated again. The effect is to swing the entire beam away from the normal.

e. Refraction may be visually demonstrated by placing the straight edge of a sheet of paper at an angle under the edge of a glass plate held vertically (B, fig 2-23). The straight edge of the sheet of paper will appear to have a jog in it directly under the edge of the glass plate. That portion of the paper on the other side of the glass will appear to be displaced due to refraction. As the sheet of paper is moved to change the angle of its straight edge, the amount of refraction will be increased or decreased. If the straight edge of the paper is viewed at right angles to the surface of the glass, there will be no refraction.

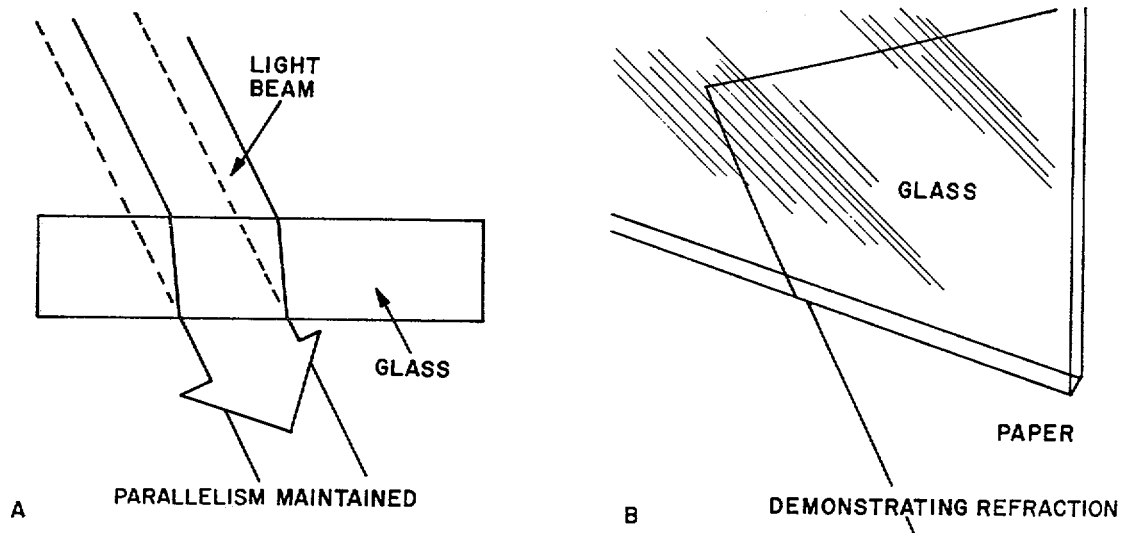

Figure 2-23. Effects of refraction.

AR910029

**2-11. Law of Refraction.**

a. The law of refraction can be stated as follows: In passing from a medium of lesser optical density to one of greater optical density, the path of light is deviated

toward the normal. In passing from a medium of greater optical density to a medium of lesser optical density, the path of light is deviated away from the normal (fig 2-24).

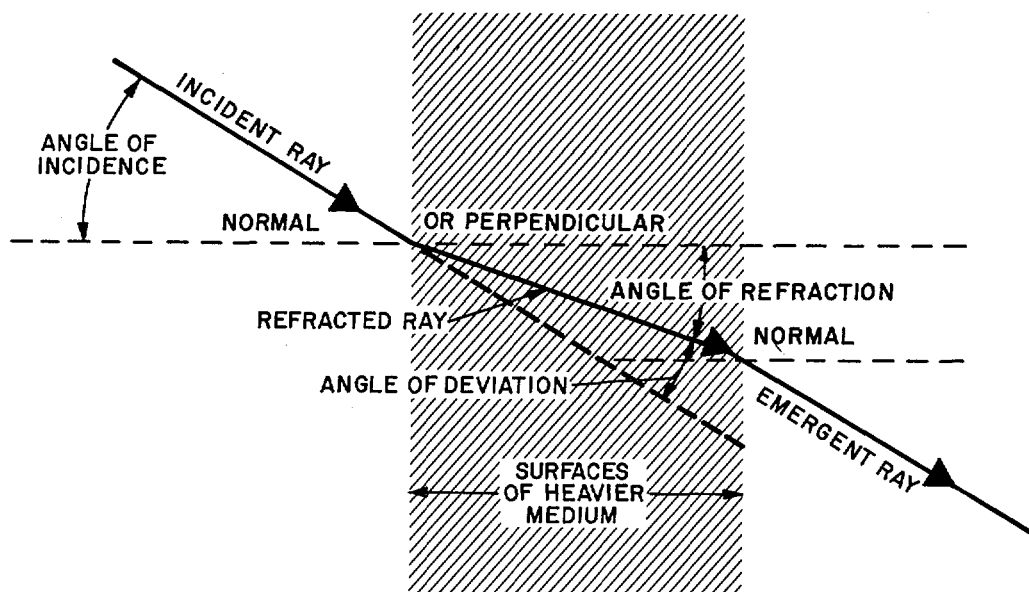

AR910030

Figure 2-24. Terms used with reference to refracted light.

b. The greater the angle at which the light strikes the medium and the greater the difference in optical density between the two mediums, the greater the bending. If the faces of the medium are parallel, the bending at the two faces is always the same so that the beam which leaves the optically denser medium is parallel to the incident beam (A, fig 2-23).

c. The ray which strikes the surface is called the incident ray (fig 2-24). The ray entering the second medium is the refracted ray. The ray leaving the second medium is the emergent ray. An imaginary line at right angles to the surface of the medium at the point where the ray strikes or leaves the surface is termed the normal or perpendicular. The angle between the incident ray and the normal is the angle of incidence. The angle between the refracted ray and an extension of the incident ray is termed the angle of deviation. It is the angle through which the refracted ray is bent from its

original path by the optical density of the refracting medium. The angle formed by the refracted ray with the normal is called the angle of refraction. The incident ray, refracted ray, emergent ray, and the normal all lie in the same plane (fig 2-24).

d. The angle of refraction depends on the relative optical density of the two mediums as well as on the angle of incidence.

e. An equation known as Snell's law may be used to determine the angle of refraction (r) if the angle of incidence (i) and the index of refraction (para 2-12c) of each medium are known (fig 2-25).

$$\text{This equation is } \frac{\sin i}{\sin r} = n \text{ where } n \text{ is the index of refraction of the second medium.}$$

quotient of the indices of refraction of the two mediums. If one of the mediums is air, n is practically the index of refraction of the second medium.

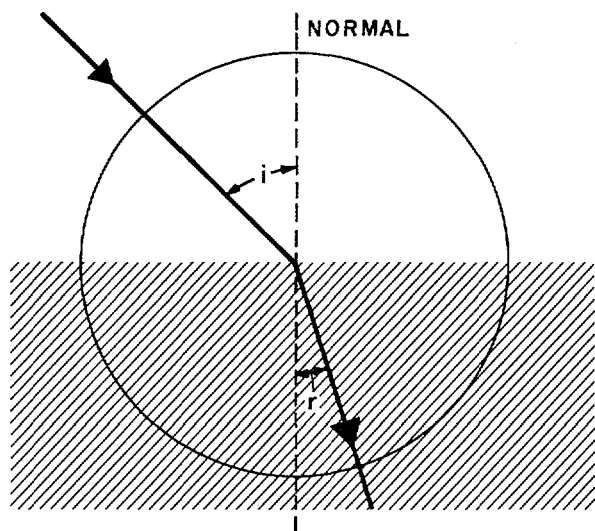

AR910031

Figure 2-25. Index of Refraction.

**2-12. Index of Refraction.**

a. Light travels through substances of different optical densities with greatly varying velocities. For example, the speed of light in air is approximately 186,000 miles per second; in ordinary glass, it is approximately 120,000 miles per second.

b. The ratio between the speed of light in vacuum and the speed of light in a medium is known as the index of refraction. The index of refraction is usually indicated by letter *n* and is determined by dividing the speed of light in a vacuum by the speed of light in the particular medium.

$$\text{Index of Refraction} = \frac{\text{Velocity in Vacuum}}{\text{Velocity in Medium}}$$

The index of refraction *n*, of a substance, can be

determined from the equation of Snell's law (para 2-11e) by actually measuring the angles *i* and *r* in a simple experiment, inasmuch as air can be used instead of vacuum for all practical purposes.

c. The following listing contains the indices of refraction of a number of substances.

**NOTE**

For most computations, the index of air is considered to be unity (1.000). The error introduced equals approximately 0.03 percent.

Vacuum .....	1.000000
Air .....	1.000292
Water .....	1.333
Boro-silicate crown glass.....	1.517
Thermosetting cement.....	1.529
Thermoplastic cement (Canada balsam) .....	1.530
Gelatin .....	1.530
Light flint glass.....	1.588
Medium flint glass.....	1.617
Dense flint glass .....	1.649
Densest flint glass .....	1.963

**2-13. Atmospheric Refraction**

a. At a surface separating two media of different indices of refraction, the direction of the path of light changes abruptly when passing through the surface. If the index of refraction of a single medium changes gradually as the light proceeds from point to point, the path of the light will also change gradually and will be curved rather than in a straight line.

b. Although air at its densest has a refractive index on only 1.000292, this is sufficient to bend light rays from the sun toward the earth when these rays strike the atmosphere at an angle (fig 2-26). The earth's atmosphere is a medium which becomes denser toward the surface of the earth. The result is that of light traveling through the atmosphere toward the earth at an angle does not travel in a straight line but is refracted and follows a curved path. From points near the horizon, the bending of light is so great that the setting sun is seen after it is completely below the horizon (fig 2-27).

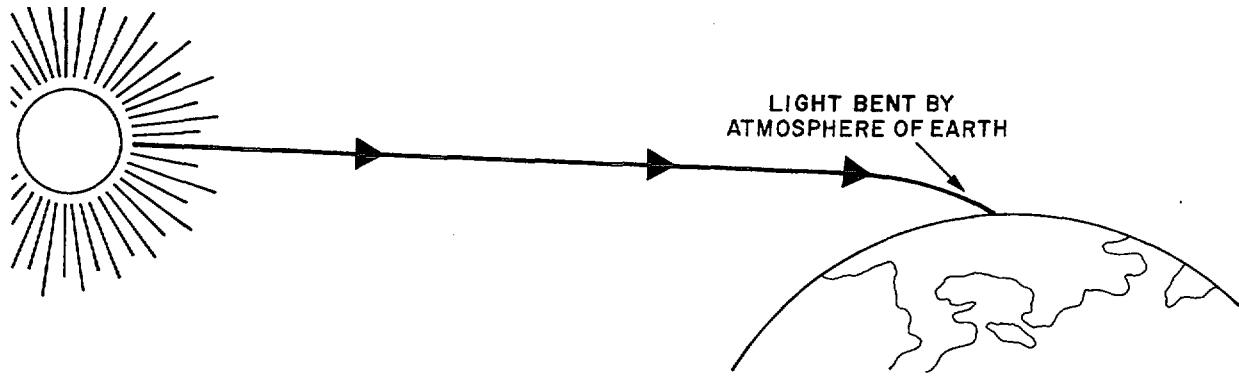

Figure 2-26. Atmospheric refraction bends sun rays.

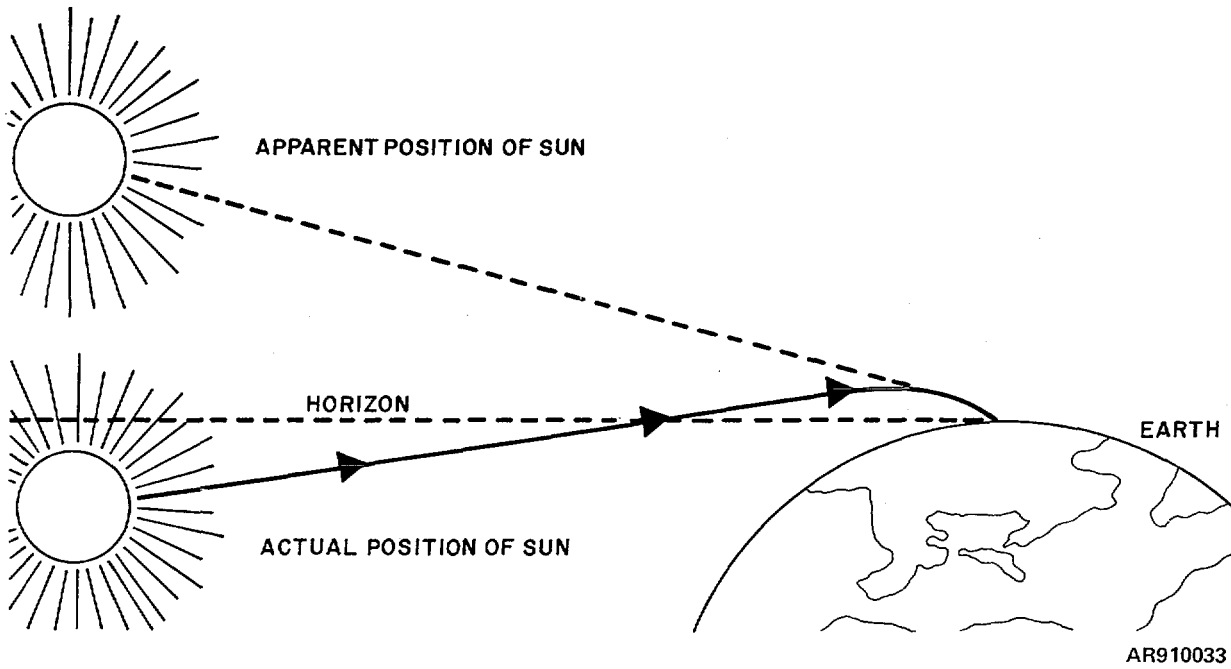

Figure 2-27. Sun below horizon seen by refracted light.

c. The bending of the paths of rays of light in both vertical and a horizontal plane is due to variation of the refractive index of air due to moisture and temperature variations. This variation is generally so small that it can be neglected in many types of observation made with fire-control instruments. In very careful surveys of large areas, this effect is eliminated by repeating the

observations on different days and under different conditions. In the aiming of guns over wide expanses of water as must be done by coast artillery, a special instrument (the depression position finder) takes atmospheric refraction as well as other conditions into consideration.

d. Over large areas of heated sand or over water, conditions are such as to produce strata or layers of air differing greatly in temperature and refractive index. Under such conditions, erect or inverted and sometimes much distorted images are formed which can be seen from a great distance. These images are known as mirages.

e. On a hot day, the columns of heated air rising from the earth are optically different from the surrounding air and rays of light are irregularly refracted. The air is turbulent and conditions under which observations are made are changing all the time. Consequently, an object viewed through such layers of air appears to be in motion about a mean position. In such cases the air is said to be "boiling" or the image is "dancing" due to "heat waves." This condition is particularly detrimental when a high-power telescope is employed. Under such conditions it is usually impossible to use an instrument of more than 20 power.

#### 2-14. Refraction Through Triangular Glass Prism.

a. Unlike a plate of glass, a prism has its faces cut at an angle. Refraction through a triangular glass prism differs from refraction through a sheet

of glass with parallel surfaces because the light which penetrates the base or thicker part of the prism must travel longer and at less speed in an optically denser medium than the light passing through the apex or thinner part of the prism. Rays of light emerging from a plate of glass with parallel surfaces always travel in a parallel direction with the incident rays; rays emerging from a prism always travel at different angles from the incident rays.

b. The laws of refraction apply to prisms just as they do to plates of glass with parallel surfaces. These laws may be applied to plot the paths of light through any prism.

c. When a ray of light strikes the surface of a prism, the refracted ray (fig 2-28) is bent toward the normal according to the law of refraction. The refracted ray is bent away from the normal on leaving the prism. Thus, the path of the ray is deviated at the first surface of the prism and then further deviated at the second surface. In both cases, the ray is bent toward the thickest part of the prism.

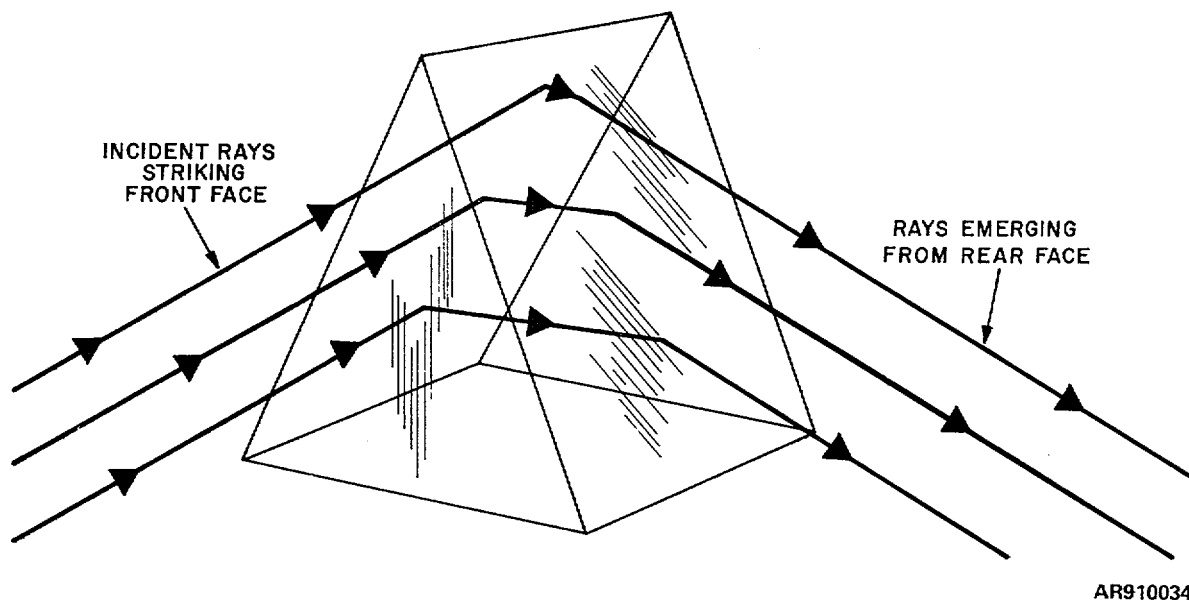
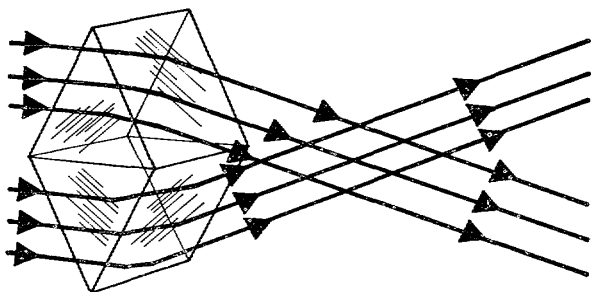

Figure 2-28. Path of light ray through prism.

#### 2-15. Refraction Through Lenses.

a. *Convergent Lens.* If two prisms are arranged base to base (fig 2-29), rays of light striking the

front surfaces will pass through the prisms. The rays emerging from one prism will cross the emergent rays of the other prism.



AR910035

Figure 2-29. Deviation of rays by two prisms, base to base.

(1) If the two prisms are cut in semicircular form, their surfaces made spherical, and the two bases cemented together, the result will be an optical element known as a convergent lens. (All convergent lenses are thicker at the center than at the edges. ) When parallel rays of light strike the front surface of a convergent lens (fig 2-30), all rays pass through the lens and converge to a single point where they cross (color and other aberrations are disregarded at this time). Such a lens may be thought of as consisting of an infinite number of prisms arranged so that each directs light rays to the same single point. The lens bends the rays as a prism does but, unlike a prism, it brings them to a point.

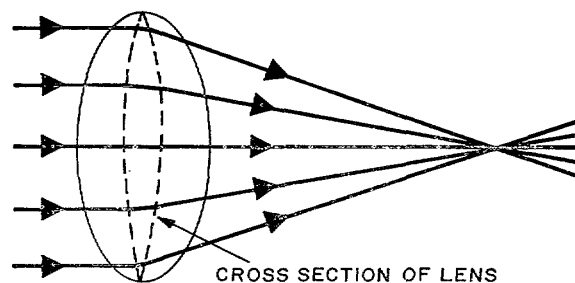

AR910036

Figure 2-30. Deviation of rays by convergent lens

(2) Myriads of rays may be considered to come from every point of light on an object. Consider the refraction of three such rays from a point of light passing through a convergent lens (fig 2-31) to intersect at a point on the other side of the lens. On the basis that a lens bends the rays as a prism does, rays passing through the upper and lower portions of the lens would be bent toward the thickest part of the lens upon striking the first surface and bent again toward the thickest part in emerging. As the result, they would converge on the other side. A straight line drawn through the center of the two spherical surfaces is termed the axis of the lens. A central or axial ray would not be deviated because it would strike the surfaces of the lens at the normal. Such a ray would join the outer rays at their convergent point.

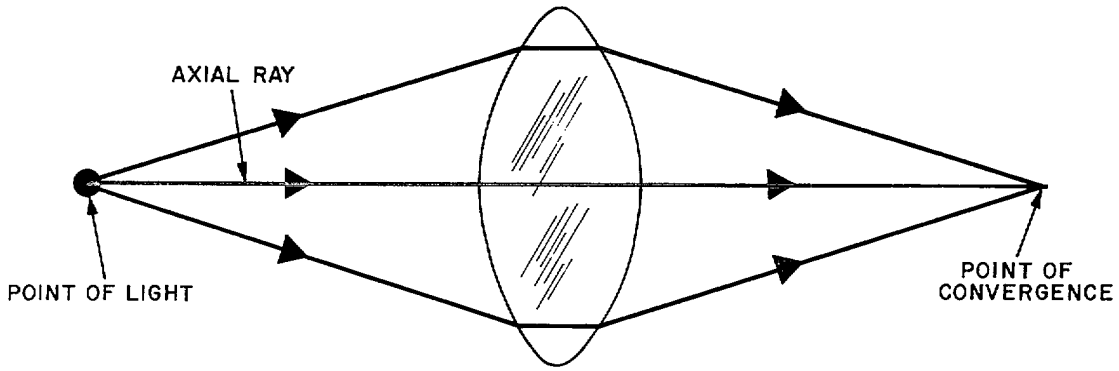
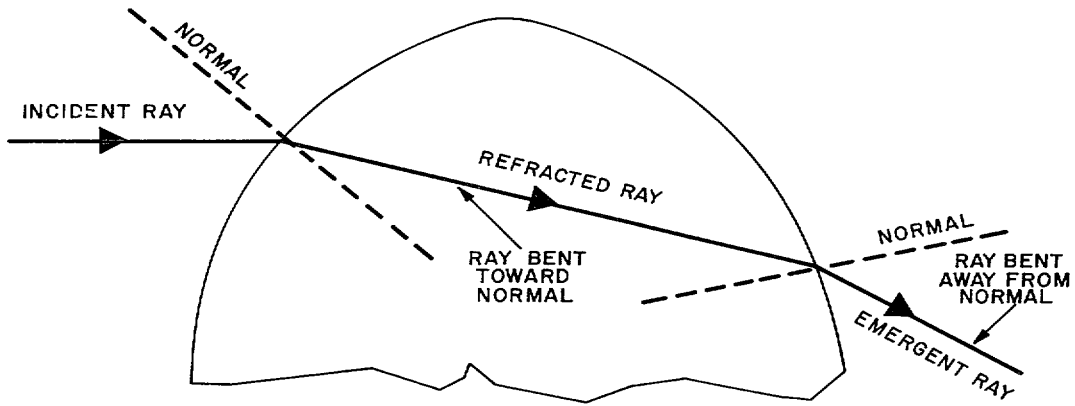

Figure 2-31. Paths of rays of light through convergent lens.

(3) The laws of refraction may be applied to plot the path of any ray through any lens. A ray entering a lens will bend toward the normal of the lens at that point (fig 2-32). The normal of an incident ray at any point on a lens is an imaginary line at right angles to the surface of the lens at the

point where the ray enters. As the refracted ray leaves the lens as the emergent ray, it is bent away from its normal. The normal of any emergent ray is an imaginary line at right angles to the surface of the lens at the point where the ray emerges from the lens.



AR910038

Figure 2-32. Law of refraction applied to lens.



b. Divergent Lens. A lens of a different type can be approximated by placing two prisms apex to apex (fig 2-33). If rays of light strike the front surfaces of the prisms, the rays will pass through and, in accordance with the law of refraction, those passing through the upper prism will travel upward while those passing through the lower prism will travel downward. Now assume that the front and rear surfaces of this pair of prisms have been rendered spherical and that the two prisms have been converted into a lens (fig 2-34). All rays of light, except the axial ray, passing through this lens would spread out or diverge but instead of splitting in two at the axis would diverge evenly in a spherical manner. This type of lens is known as a divergent lens. (All divergent lenses are thicker at the edges than at the center.

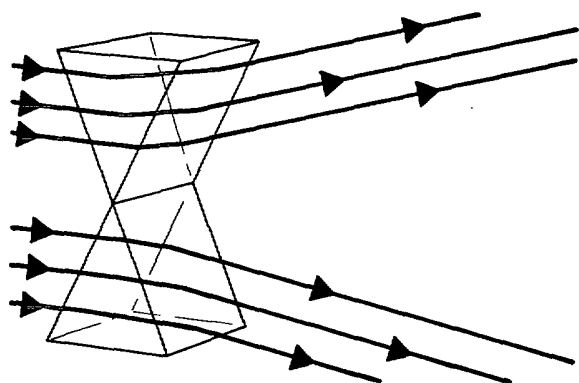

AR910039

Figure 2-33. Deviation of rays by two prisms, apex to apex.

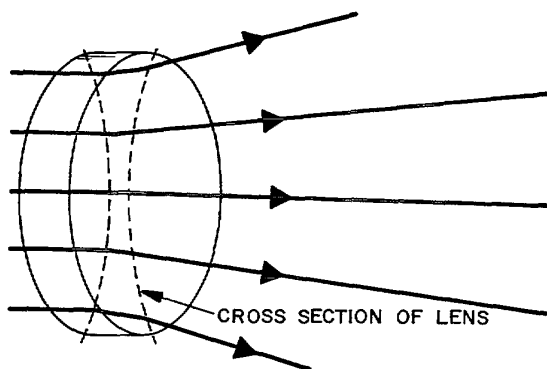

AR910040

Figure 2-34. Deviation of rays by divergent lens.

**2-16. Total Internal Reflection and Critical Angle.**

a. When light passing from air into a more optically dense medium, such as glass, strikes the boundary surface, it is refracted. This occurs regardless of the incident angle except when light is on the normal (no refraction occurs). However, when light attempting to leave a more optically dense medium for a less optically dense medium strikes the boundary surface, it may be reflected rather than refracted even though both mediums are perfectly transparent. This is known as total internal reflection and occurs when the incident angle exceeds a certain critical angle. The critical angle depends upon the relative indices of refraction of the media. Critical angles for various substances, when the external medium is air, are listed in paragraph 2-17.

b. The total internal reflection of light can be illustrated by following the rays from a light source under water. Water has a critical angle of 48° 36 minutes, when the external medium is air. Rays of light from such a source would be incident at various angles on the surface separating the water and air (fig 2-35). As the angle of incidence of the light rays increases, the deviation of the refracted rays becomes proportionately greater. A point is reached where an incident ray is deviated to such an extent that it travels along the surface of the water and does not emerge into the air. The angle formed by this incident ray and the normal is the critical angle of the medium.

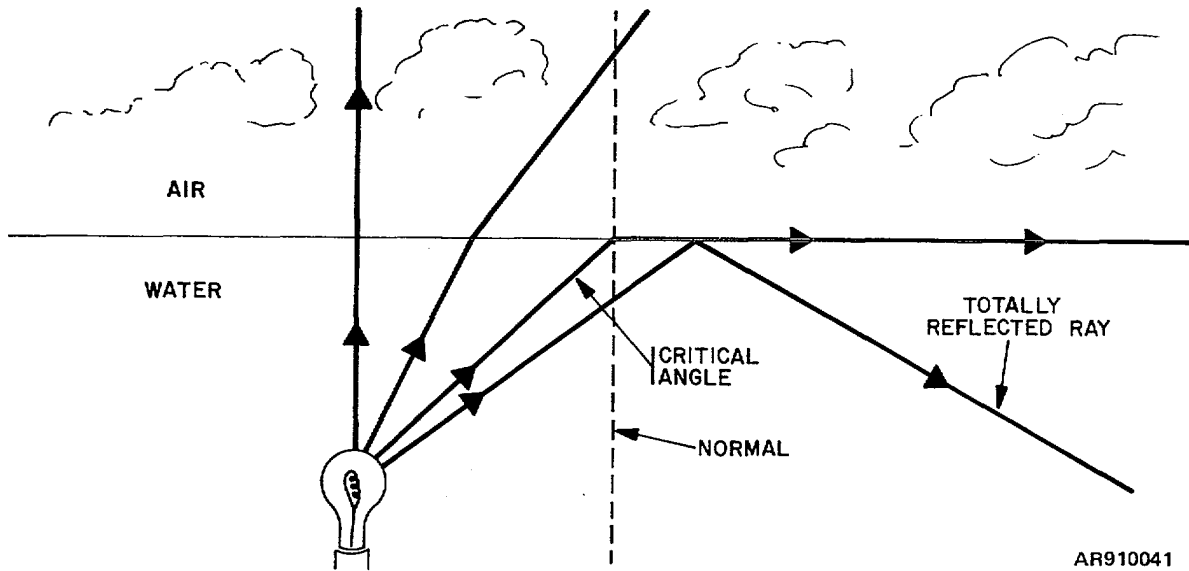
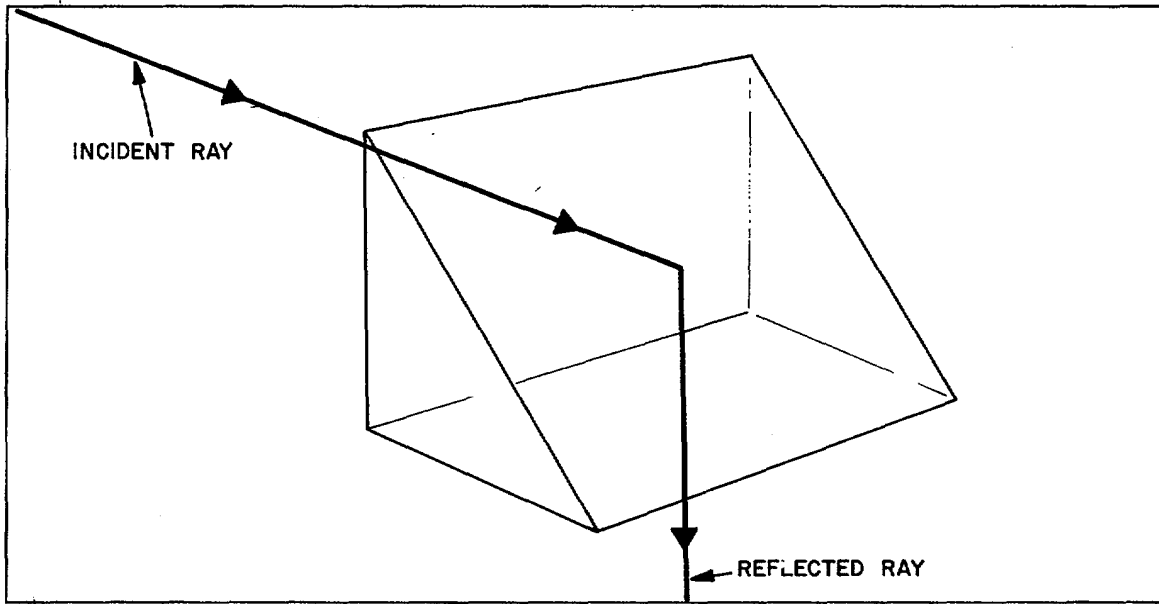

Figure 2-35. Angles of light rays from an underwater source.

c. All rays traveling in an optically dense medium and striking the surface with an angle of incidence that is less than the critical angle of the mediums are refracted and pass into the optically lighter medium in accordance with the laws of refraction. All such rays striking at an angle of incidence greater than the critical angle of mediums are reflected inwards in accordance with the laws of reflection.

d. The critical angle has a practical application in the design of prisms used in fire-control instruments. In such instruments, it is quite often necessary to change the course of the path of light. This deviation could be accomplished by mirrors but the prisms used perform the task more satisfactorily. When prisms are employed at angles greater than the critical angle of the substance of which they are made, their reflecting surfaces do not require silvering, yet these surfaces appear to be silvered when one looks into such a prism.

e. Consider a prism with two faces at right angles and a back or hypotenuse at a 45° angle (A, fig 2-36). An incident ray, striking one of the right-angle faces in the direction of the perpendicular or the normal, passes into the prism without refraction or deviation until it hits the boundary of the medium (back of the prism). Since the angle of the back is 45° and the critical angle of the glass of the prism is 42°, the ray cannot pass through the back surface of the prism. Instead, it is totally reflected. Inasmuch as the angle of incidence between the incident ray and the normal (at the back surface) is 45°, the angle of reflection would be the same because these angles are always equal. The result is that the ray is reflected a total of 90°, strikes the surface of the other right-angle face of the prism in the direction of the normal, and passes out of the prism without further deviation.



A — SINGLE RAY

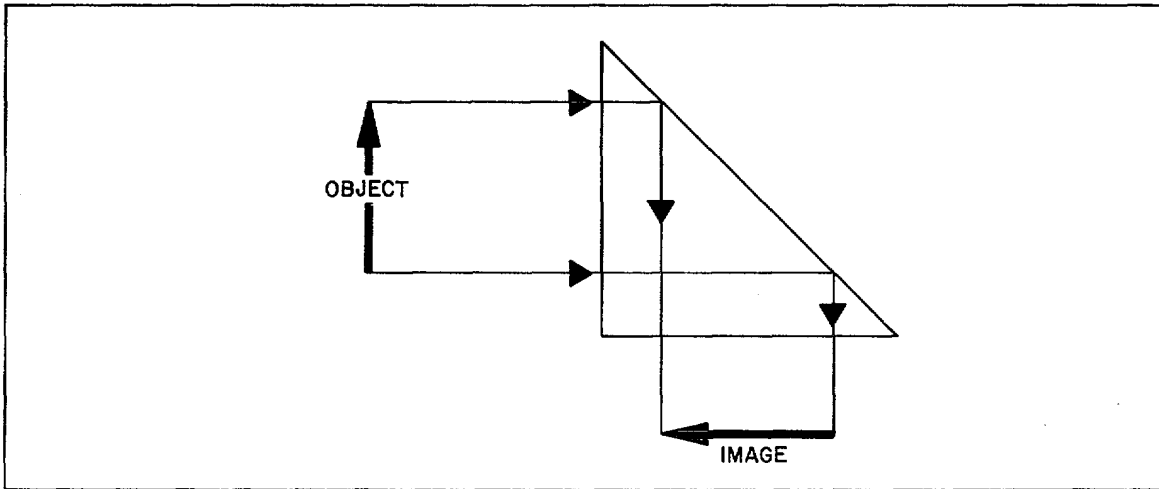

B — IMAGE FORMATION

AR910042

Figure 2-36. Total internal reflection in 90-degree prism.

f. At any boundary between different media there is both reflection and refraction of an incident ray, excepting total reflection (para 2-7f). Figures 2-35 and 2-36, therefore, are only approximations.

g. The critical angle of any substance can be easily calculated from the equation of Snell's law (para 2-11. e),  $n = \frac{\sin n}{\sin r}$

It follows that:

$$\sin r = \frac{\sin 90^\circ}{n} = \frac{1}{n}$$

For water,  $n=1.333$  (para 2-12c),  $\sin r = \frac{1}{1.333} = 0.750187$ , and the critical angle  $r = 48^\circ 36 \text{ min}$  (para 2-17a).

**2-17. Critical Angles of Various Substances.**

a. The critical angles for various substances, when the external medium is air, are as follows:

Water .....	48° 36 min
Crown glass .....	41° 18 min
Quartz .....	40° 22 min
Flint glass .....	37° 34 min
Diamond.....	24° 26 min

b. The small critical angle of diamond accounts for the brilliance of a well-cut diamond. It is due to a total internal reflection of light which occurs for a greater variety of angles than in any other

substance. The light entering the diamond is totally reflected back and forth a great number of times before emerging, producing bright multiple reflections.

**Section IV. IMAGE FORMATION**

**2-18. General.** In considering the principles of the formation of images by lenses, for simplicity of explanation it will be assumed that perfect single lenses are used.

**2-19. Classification of Images.**

a. *Virtual and Real Images.* Two types of images are produced by optical elements, virtual images and real images.

(1) *Virtual Images.* A virtual image is so called because it has no real existence. It exists only in the mind and cannot be thrown upon a screen because it is apparent only to the eyes of the observer. A familiar example is the virtual image formed by a mirror. The image of the person looking into the mirror appears to be on the other side of the mirror (fig 2-37). No trace of the image can be seen on the back of the mirror. A plane mirror produces a virtual image resulting in an optical illusion in which the object appears to be behind the mirror.

(2) *Real images.* A real image actually exists. It can be thrown upon a screen. The lenses of the human eye and the camera form real images. The real image formed by a camera can be seen on the ground glass (fig 2-38).



AR910043

Figure 2-37. Virtual image reflected by plane mirror.

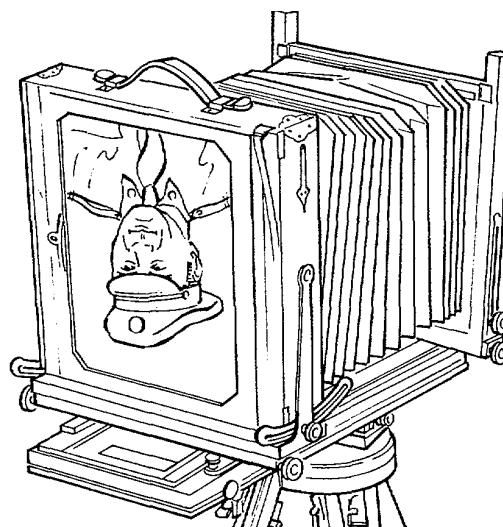

AR910044

Figure 2-38. Real image formed on ground glass of camera.

b. *Erect, Inverted, Normal, and Reverted Images.* When an image is reflected or refracted by optical elements, the parts of the object may be seen as being transposed horizontally, vertically, or both. This is illustrated by what happens to the letter F shown in figure 2-39 and by B, figure 2-36.

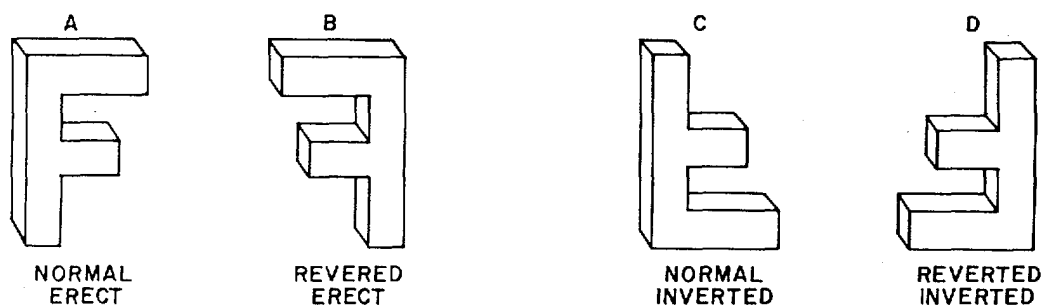

AR910045

Figure 2-39. Letter F as reflected by optical elements

(1) An image, regardless of size, that shows the face of an object unchanged is said to be normal and erect (A, fig 2-39). When the object is seen as horizontally transposed through 180°, it is termed reverted and erect (B, fig 2-49). Reversion is the effect seen in a vertical mirror where the image is reversed so that the right side of the object becomes the left side of the image (fig 2-37).

(2) The image of an object with its face unchanged but upside down is termed normal and inverted (C, fig 2-39). Inversion is the effect seen in a horizontal mirror where the image is inverted so that the top of the object becomes the bottom of the image. If it appears turned from left to right as well as upside down, it is said to be reverted and inverted (D, 2-39). This is the effect seen on the ground glass of a camera (fig 2-38).

mirror, it appears to be located at a distance behind the reflecting surface equal to the distance of the object from the front of the mirror. The image is erect and reverted as are all single reflections from vertical plan mirrors.

b. In a dark room, the image of a tiny point of light as viewed in the mirror appears to the observer to be located behind the mirror and on the other side of the room where it actually is. The observer sees along the path of the reflected ray to the point where the incident ray is reflected by the mirror. His line of sight is extended in his mind in a direct line through and beyond the mirror. The apparent position of the point of light in the mirror is located directly across the room from the light source and at the same distance behind the mirror as the light source is in front of the mirror (EYE "A", fig 2-40).

## 2-20. Image Reflection by Plane Mirror.

- a. When the image of an object is seen in a

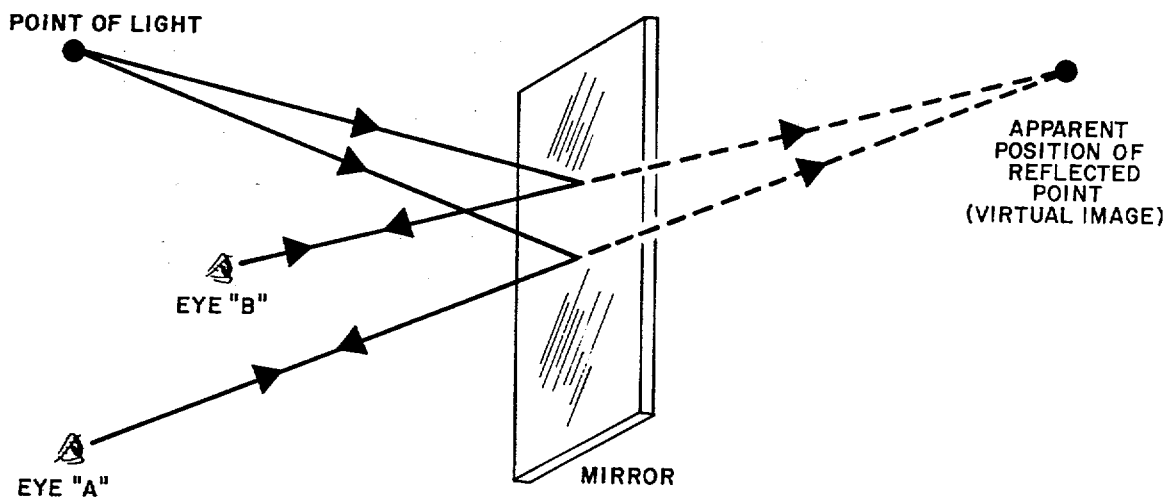

AR910046

Figure 2-40. Reflection of point of light in mirror.

c. Regardless of where the observer stands, if he can see the reflection of the point of light in the mirror, its apparent position is unchanged. This holds true whether he walks forward along his line of sight without affecting the angles of incidence and reflection of the ray or steps to either side changing his line of sight and the angles of incidence and reflection (EYE "B", fig 2-40). It is the object (source of light) that is reflected and the apparent position of its reflection is changed only when the position of the object or of the mirror is changed.

d. Now, assume that the light source is replaced

by a cutout letter F covered with luminous paint (fig 2-41). Light from every point on the letter sends out incident rays which are reflected by the mirror. Each incident ray and reflected ray obeys the laws of reflection and their paths can be plotted accordingly. As the result, the entire image formed by the combination of this infinite number of images of individual points of light is reflected to the eye of the observer. The observer, looking along the paths of the reflected rays, sees the image formed by the points of light. The image he sees appears to be in back of the mirror as an erect, reverted image (fig 2-41).

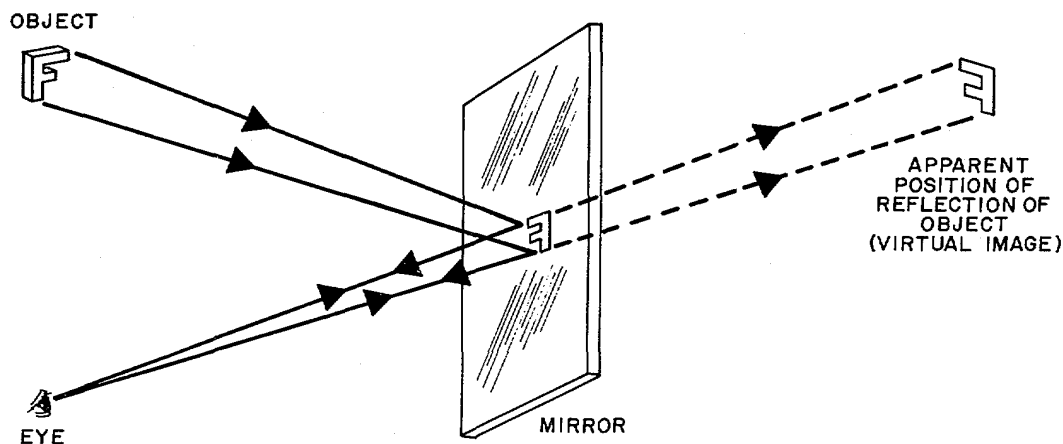

AR910047

Figure 2-41. Reflection of letter F in mirror.

## 2-21. Image Transmission by Mirror and Prism.

*a. Image Transmission by Mirror.* Image transmission by mirror is image reflection put to practical use. The mirror is mounted so that it will transmit the light that falls upon it to whatever point is desired. If this cannot be accomplished with a single mirror, a second mirror is placed to catch the reflected light from the first mirror and transmit it again.

(1) Consider two mirrors placed at 90° angles to one another. The light coming from the letter F falls onto the reflecting surface of one of the mirrors (fig 2-42). Light rays from every point on the letter F are reflected by the first mirror, according to the laws of reflection, to the second mirror, and reflected again, this time parallel to the original paths of the light rays. The image will have been reflected a total of 180°.

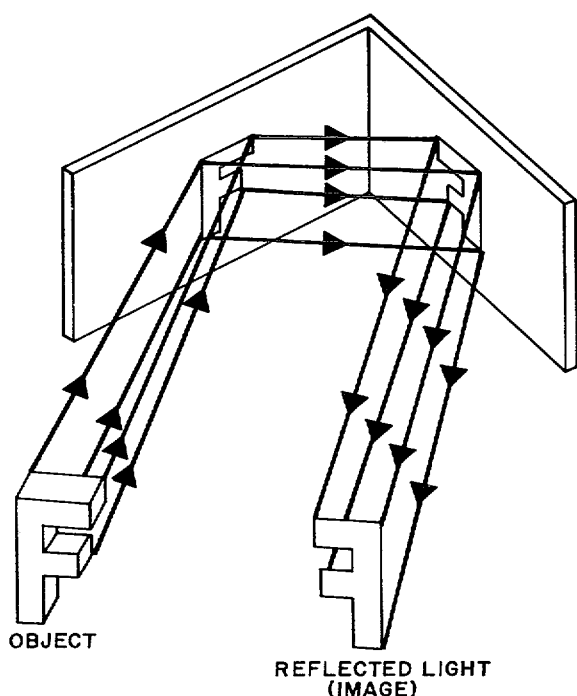

AR910048

Figure 2-42. Image transmission by mirrors.

(2) The combination of two mirrors at  $90^\circ$  angle does not invert or revert the image when reflection takes place in the horizontal plane (the figure shows the rear of the object and the front of the image). If reflection takes place in the vertical plane an inverted, reverted image is obtained.

*b. Image Transmission by Prism.* Image transmission by prism can be brought about in practically the same manner as an image is transmitted by one plane mirror (B, fig 2-36) or two plane mirrors (fig 2-43). Actually, the reflecting surfaces of a prism are plane mirrors. These surfaces are silvered when the angle at which the light strikes is less than the critical angle (para 2-16) of the material from which the prism is made; the surfaces require no reflecting agent when this angle is greater than the critical angle.

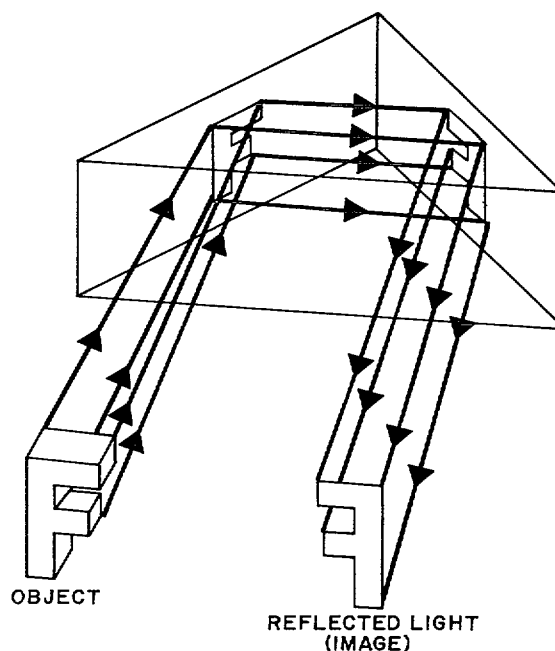

AR910049

Figure 2-43. Image transmission by prism.

*c. Comparison.* When mirrors are used, the image is reflected through air; when a prism is used, the image is reflected through glass. While being transmitted through glass, the paths of the rays of light are not deviated because they travel in a medium of constant optical density. These paths are not deviated upon entering or leaving the glass of the prism provided the light rays strike the surface of the glass in the direction of the normal, at right angles to the surface.

## 2-22. Focal Length and Focal Plane.

*a. Focal Point of Convergent Lens.* When light strikes and passes through a convergent lens, the rays from a point of light intersect at a point on the opposite side of the lens. The point at which the rays intersect is termed the focal point.

*b. Focal Point-Location.* The focal point of a lens will vary in relation to the distance of the



object. If a sheet of ground glass or thin paper is placed across the back of a camera or held in back of a lens at a distance that will permit the lens to focus the images of objects on the glass or paper, images of all distant objects may be brought into sharp focus at one time regardless of their distance providing the distance is great -and rays of light are almost parallel. An object very close to the lens will be out of focus. The ground glass or paper will have to be moved backward to bring such an object into sharp focus; then the more distant objects will be out of focus.

c. *Point of Principal Focus.* The focal point where almost parallel rays from a very distant object intersect is called the point of principal

focus (fig 2-44). The point of principal focus of a lens does not vary, it always remains at the same distance from the lens. The optical center of a lens is a point at the center of the thickest part of a converging lens or the thinnest part of a divergent lens. It lies on a straight line connecting all the principal focal points of the lens (fig 2-45). Rays of light pass through the optical center without deviation. The distance from the point of principal focus to the optical center of a convergent lens is the focal length of the lens. This is a fundamental concept which must be kept in mind throughout to understand optical diagrams. The thicker the lens in relation to its size or the steeper the curves of the lens, the shorter its focal length will be.

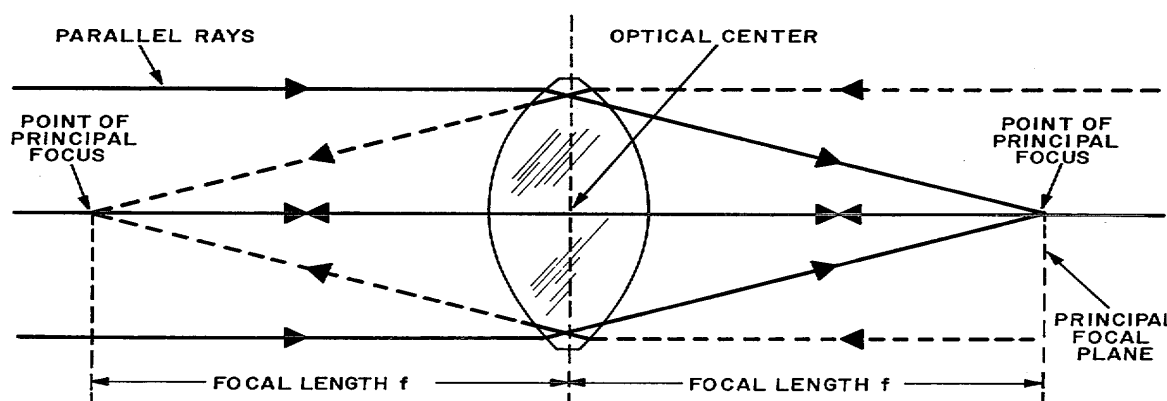

AR910050

Figure 2-44. Focal lengths of convergent lens.

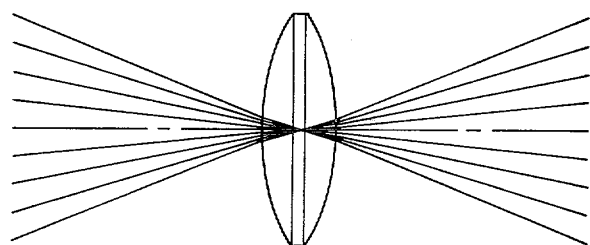

AR910051

Figure 2-45. Optical center of lens.

d. *Focal Plane.* The focal plane of the lens (fig 2-44) is a thin flat area at right angles to the central axis of the lens in all directions from the focal point. It is the area that is occupied by the ground glass or paper which might be used to make the image visible. In a camera, the film is placed in the focal plane of the lens. The focal point (fig 2-46) is the image of a single point of light on the object; the focal plane is the combined image of all the points of light on the object. The principal focal plane of the lens is the focal plane passing through the point of principal focus (fig 2-44). In a camera, when taking a photograph of very distant objects, the film is placed in the principal focal plane of the lens.

e. *To Determine Focal Length of Convergent*

Lens. A rough determination of the focal length of a convergent lens can be secured by holding the lens to focus the image of some distant object on a sheet of paper or ground glass. When the image is clear and sharp, this will indicate that the point of principal focus has been reached. Measure the distance from the image to the optical center of the lens.

*f. Focal Length of Divergent Lens.* The point of principal focus and any focal points and focal

planes resulting from the nearness of the object to the lens are located on the side of the divergent lens toward the object or light source. The point of principal focus and other focal points are located where the emergent rays would intersect on the axis if they were extended backward as imaginary lines toward the side of the lens on which the light strikes (fig 2-46). The distance from the point of principal focus to the optical center of the lens is the focal length.

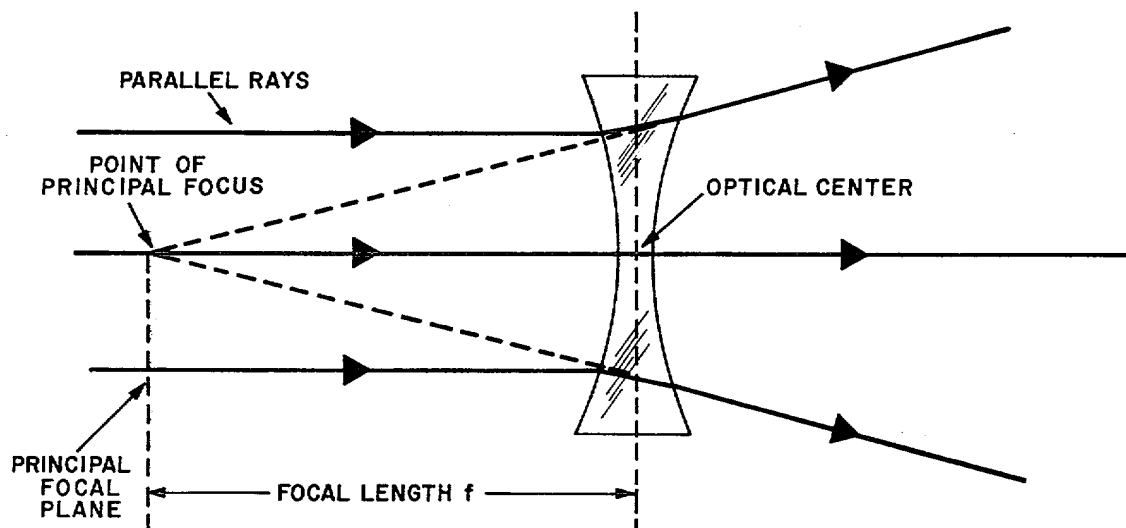

AR910052

Figure 2-46. Focal length of divergent lens.

### 2-23. Magnification and Reduction.

*a.* Magnification is the apparent enlargement of the image of the object to the eye of the observer. Common examples are the reading glass and microscope. In a fire-control instrument, magnification, by marking targets appear larger, makes them appear closer.

*b.* Optical reduction is the apparent reduction in the size of the image of the object to the observer. A negative or divergent lens placed in the floor of an airplane to permit observation functions on this principle. It makes objects appear smaller than when viewed with the unaided eye but has the advantage of increasing the field of view. A much larger area may be scanned through the relatively small opening than would be possible if the lens were not used.

*c.* The degree of magnification of an optical instrument is expressed as the power of the instrument, for example, 8-power. An 8 power (8X)

telescope will produce an image, the apparent size of which is eight times as high and eight times as wide as the image when viewed by the unaided eye.

*d.* Military targets can often be seen better with 10-power magnification than with 20-power, due to the change in the field of vision which accompanies a change in power and due to varying conditions of light. For this reason, some fire-control instruments are fitted with means for changing the power of magnification. Certain instruments provide no magnification; their primary purpose is to place a reticle in the field of vision.

### 2-24. Image Formation by Convergent Lens.

*a. Types of Images.* Images which are formed by convergent lenses may be either real or virtual images. They may be larger or smaller than the object, depending upon the distance of the object from the lens. *b.*

*Perfect Lens Assumed.* Multiple or com-

pound lenses (para 4-2) may be used to correct for color and other faults. A theoretically perfect single lens is assumed in this paragraph.

c. *Plotting the Image.* To plot the formation of an image by a convergent lens, consider that every

point of an object is emitting cones of rays of light which are incident upon the front face of the lens. Two rays from a point will be sufficient to indicate the action of the lens and to locate the image of this point (fig 2-47).

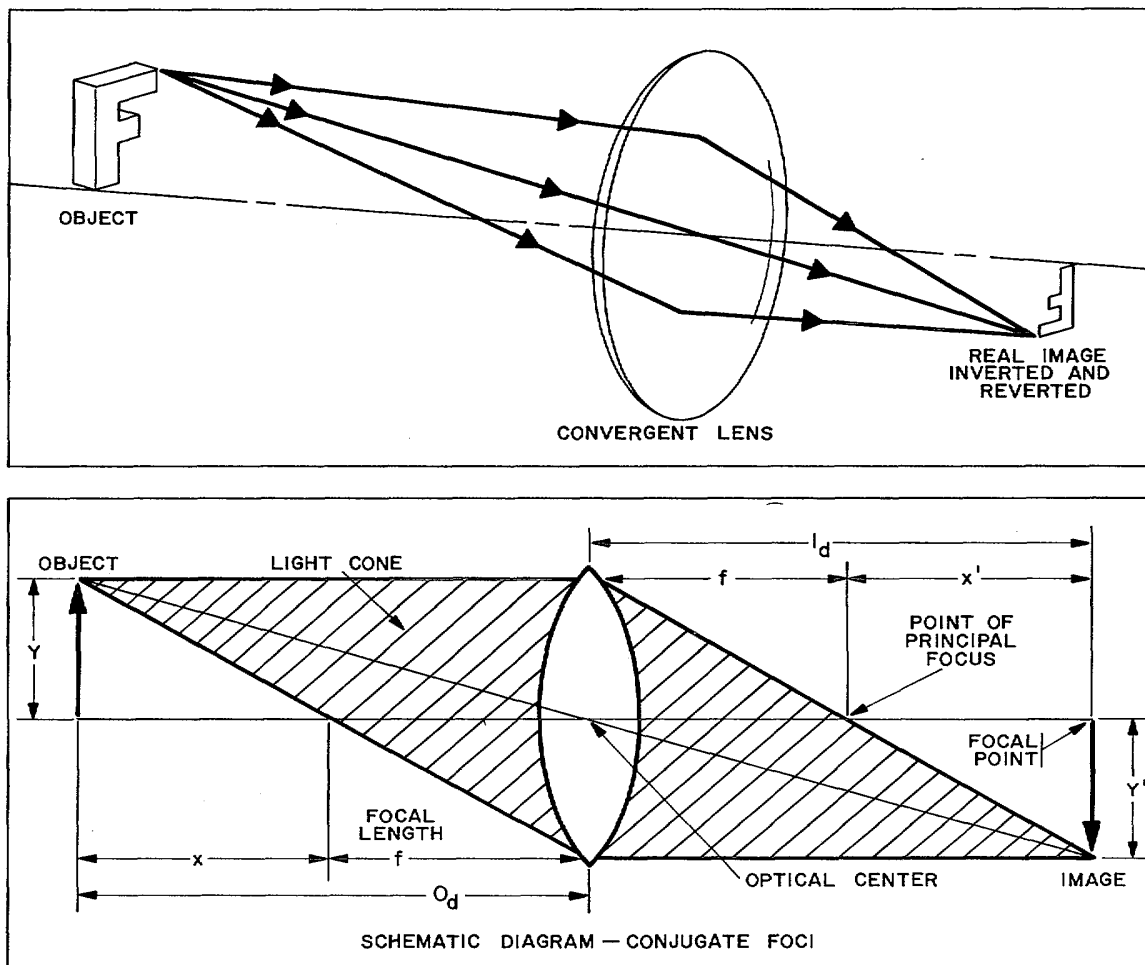

AR910053

Figure 2-47. Image formed by convergent lens.

(1) Assume that one ray from a point at the top of the object will pass through the center of the lens. Since this ray will strike the lens at the center, its path is not deviated. A second ray from this point of the object strikes the lens above the axis, is refracted upon entering and upon leaving the optically denser medium, and intersects the first ray. For this second ray, we chose a ray parallel to the axis. After passing through the lens, it will converge to the point of principal focus and thus can be easily located. The point where

the two rays intersect becomes the corresponding point for the image.

(2) Two similar rays from a point at the bottom of the object form a point of the image corresponding to the bottom of the object. Every point on the object forms its point of light on the image in the same way. Light rays from the upper part of the object form points of light on the lower part of the image and vice versa. The image is transposed diametrically and symmetrically across the optical axis from the object resulting in *in-*

version and reversion as in figure 2-47. An image formed in this way is real.

d. *Object Location and Image Size.* The image of an object located at any distance beyond two focal lengths of the lens is smaller than the object. If the object is at two focal lengths, the image is the same size. If the object is between one and two focal lengths away, the image is magnified. All of these images are inverted, reverted, and real. If the object is at one focal length, the rays are parallel after refraction; the image is said to be at infinity.

e. *Magnification by Convergent Lens.*

(1) *Conjugate foci.* These are two points so related that an object at either point will be imaged by a lens at the other point and will be a real image. The mathematical relationship is as follows

$$\frac{1}{\text{Object Distance}} \text{ plus } \frac{1}{\text{Image Distance}} = \frac{1}{\text{Focal Length}}$$

or  $\frac{1}{O_d} + \frac{1}{I_d} = \frac{1}{f}$  (fig 2-47)

$$\text{Magnification} = \frac{\text{Size of Image}}{\text{Size of Object}} = \frac{\text{Image Distance}}{\text{Object Distance}}$$

If any three of the above quantities are known, it is possible to determine the fourth by the application of simple algebra. To state magnification another way, it is simply comparing the size of the image with the size of the object or:

$$\text{Magnification} = \frac{\text{Image Size}}{\text{Object Size}} = \frac{Y_1}{Y} = \frac{I_d}{O_d} \quad \text{or}$$

$$Y = \frac{M \cdot Y_1 \cdot f}{O_d - f} \quad \frac{f - x}{x} = \frac{1}{f}$$

(2) *Magnification by reading glass.* If the object is inside one focal length of a convergent lens, the image will be on the same side of the lens as the object magnified, normal, and erect. The image will no longer be real but will be virtual. This is a condition which can be illustrated easily by the use of a reading glass (figs 2-48 and 2-69). Eyepieces of all optical instruments provide the eye with a virtual image. If the observer looks at the object, for example, a portion of a printed page, through a reading glass held close to the type, the printed letters appear larger than they actually are. As he moves the glass away from the type, each letter appears larger and remains clear provided he moves his eye backward as he moves the glass away from the printed page. At a certain point the printed letters appear at their largest and clearest. Beyond this point they become blurred and then inverted. The time when the largest and clearest view of the letters is obtained is just before the focal point of the lens has been reached. The rays from the object can be plotted for any point in the preceding demonstration (fig 2-48). A ray of light through the center of the lens passes through in a straight line unchanged. A ray which is originally parallel to the axis is directed towards the point of principal focus (para 2-22). The reason for the magnification of the image is clear considering that the virtual (not real) image is located where the emergent rays would intersect if they were extended backward as imaginary lines. These rays form a magnified image of the object which appears to be in back of the object.

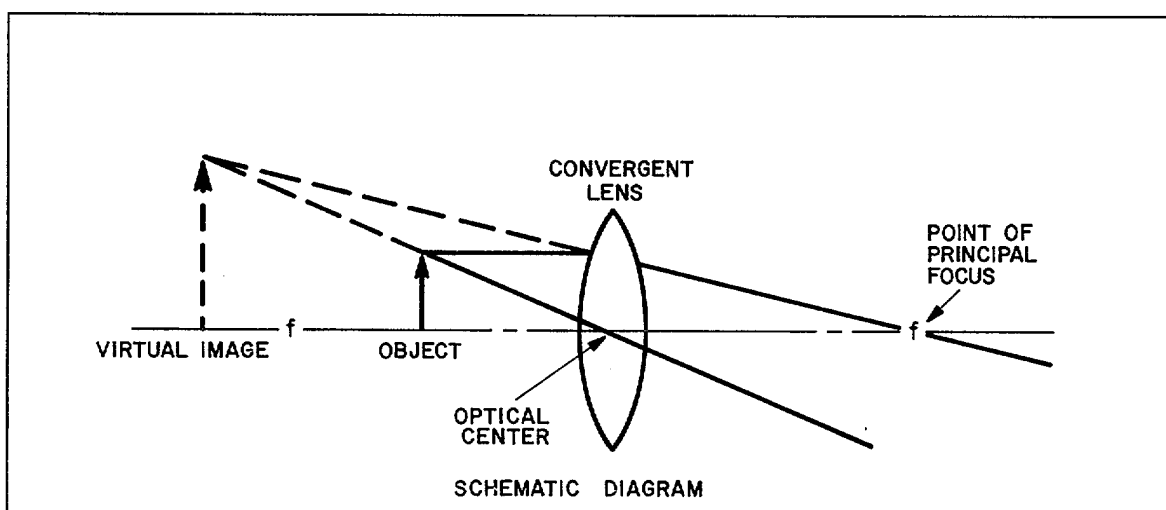
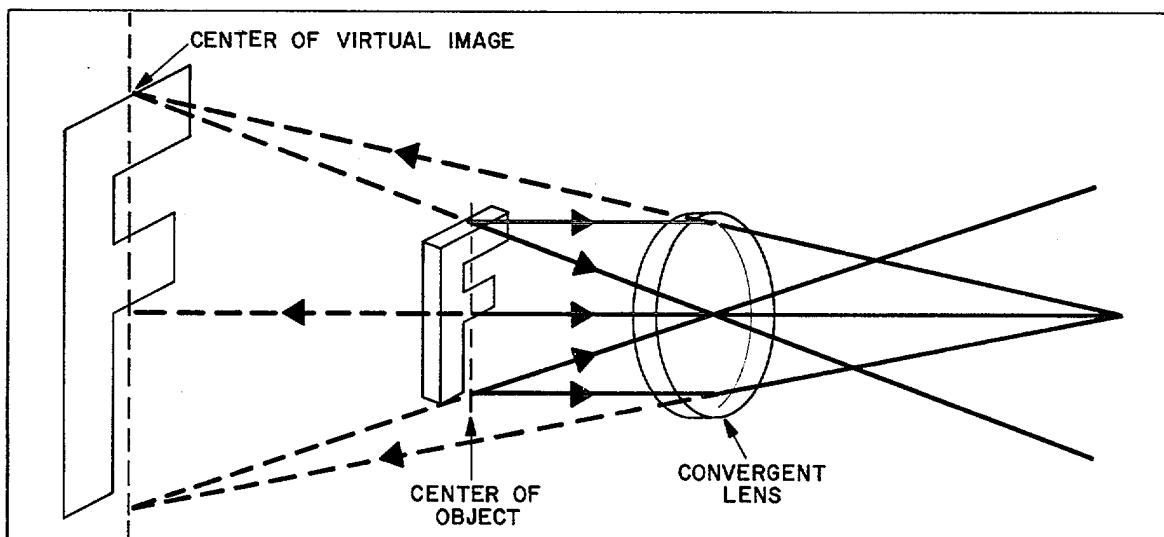

AR910054

Figure 2-48. Magnification by reading glass-object within focal length.

**2-25. Image Formation by Divergent Lens.**

a. Type of Image. Divergent lenses can form only virtual images which are erect and smaller than the object. This holds true regardless of the distance of the object from the lens. Divergent lenses are termed negative because they will produce only an image smaller than the object, they produce only virtual images, and they deviate the light outward. The virtual images formed by them are always on the same side of

b. *Plotting the Image.* Light rays from a very

distant object strike the face of a divergent lens in almost parallel rays and, after refraction, are diverted by the lens away from the axis (fig 2-49). In looking along the paths of the rays, the observer sees an apparent intersection of the rays at a point on the same side of the lens as the object. The point where the rays appear to intersect is the focal point. It is backward continuation of the emergent rays as imaginary lines. As the observer looks along the paths of these rays, he sees the virtual (not real)--image of the object located inside the intersection of these imaginary continuation lines (fig 2-50).

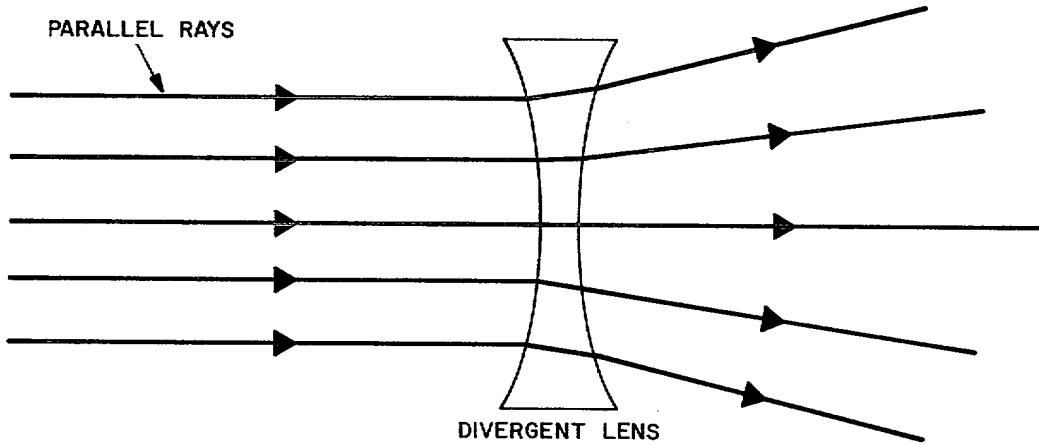

AR910055

Figure 2-49. Effect of parallel rays on divergent lens.

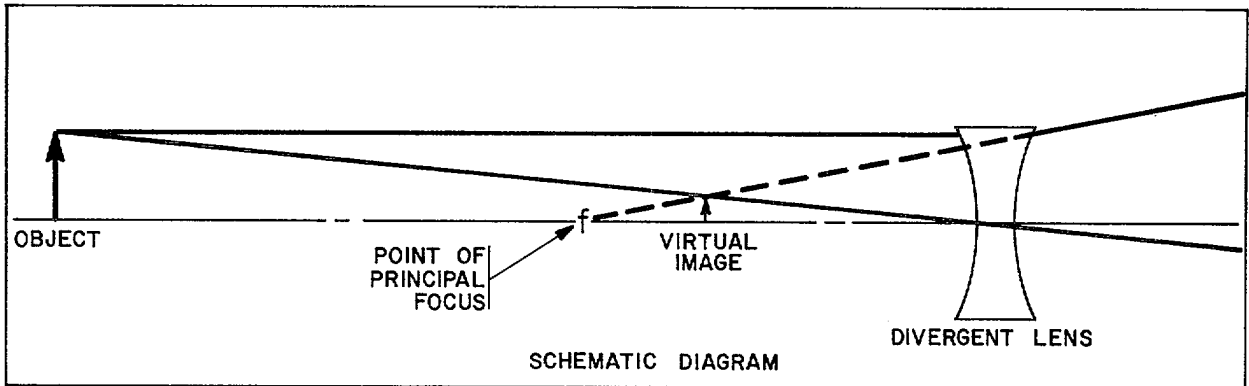
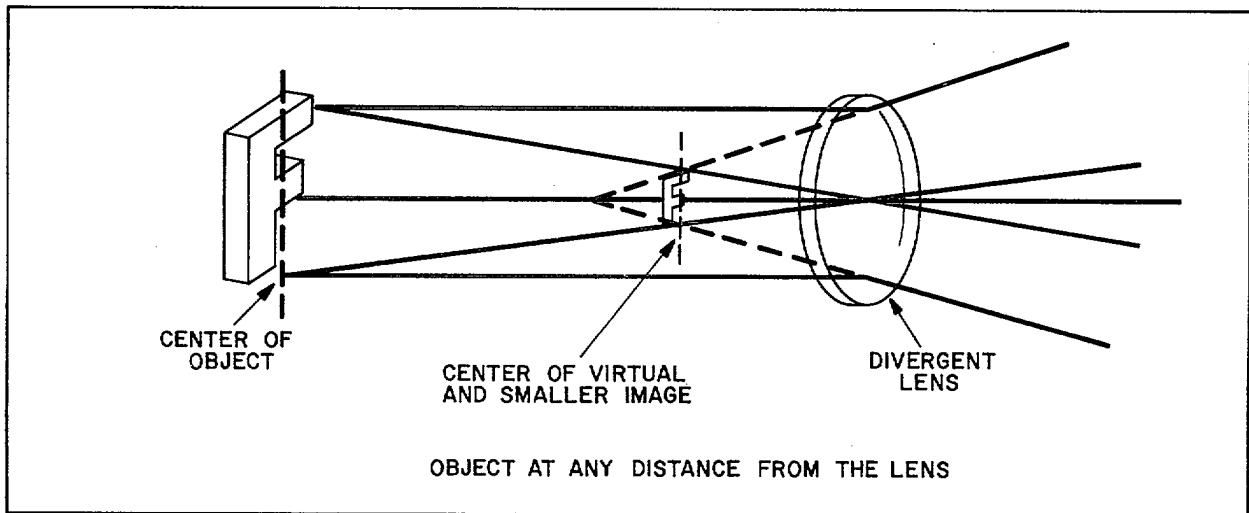

AR910056

Figure 2-50. Reduction by divergent (negative) lens.

*c. Image Size.* An observer receives the impression that the image seen on the other side of the lens is smaller than the object. This effect is known as reduction as contrasted with

magnification produced by a simple magnifier. It is useful in some camera viewfinders, but since it does not magnify or produce a real image its usefulness is limited in military instruments.

## Section V. COLOR

### 2-26. General.

*a.* Ordinary sunlight or any other "white" light is a mixture of visible light of all wavelengths. "White" light, is, therefore, a mixture of all colors.

*b.* The amount of deviation of light from its path depends upon the color of the light as well as upon the shape and optical density of the optical element. Each color of light has its own distinctive wavelength and there is a different index of refraction for each color. The unequal deviation of rays of light of various colors, dispersion as it is called, has an important effect on the formation of images, and, therefore, upon the design of fire-control instruments.

### 2-27. Separation of "White" Light.

*a.* If sunlight is passed through a slit and then

through a triangular cross-section glass prism, the emergent light is split into a number of refracted rays. If these refracted rays are made to fall upon a screen, they produce a band of colored light called the solar spectrum. The colors of the spectrum are, on order; red, orange, yellow, green, blue, indigo, and violet. About 130 distinct hues have been observed.

*b.* Each color of the spectrum represents light vibrating at a different frequency or wavelength. The shorter the wavelength, the more the rays are bent upon being refracted. Red light has the longest wavelength (A, fig 2-51); violet, the shortest. Red rays are bent the least; violet, the most; the rays of other colors are interspaced accordingly

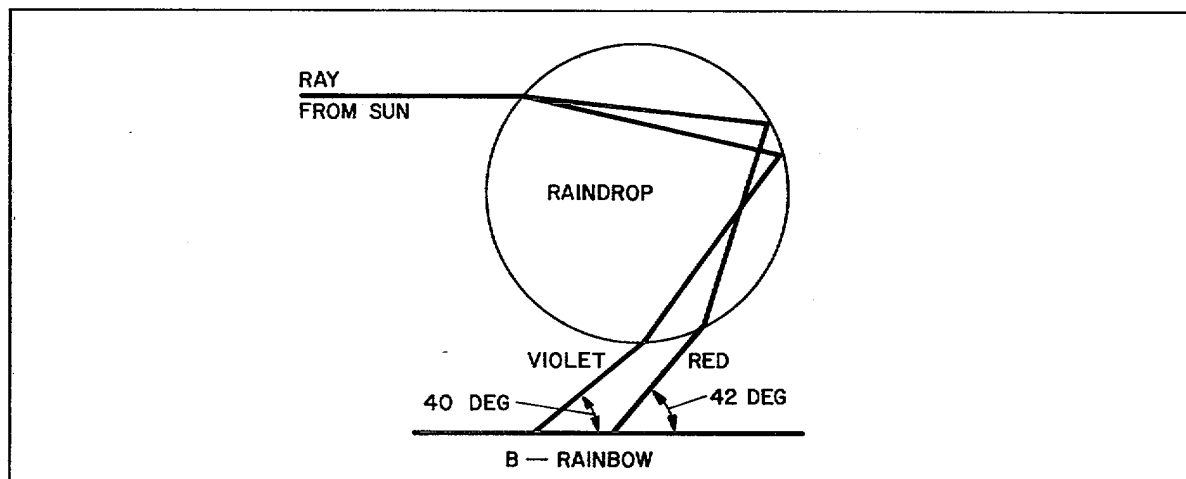
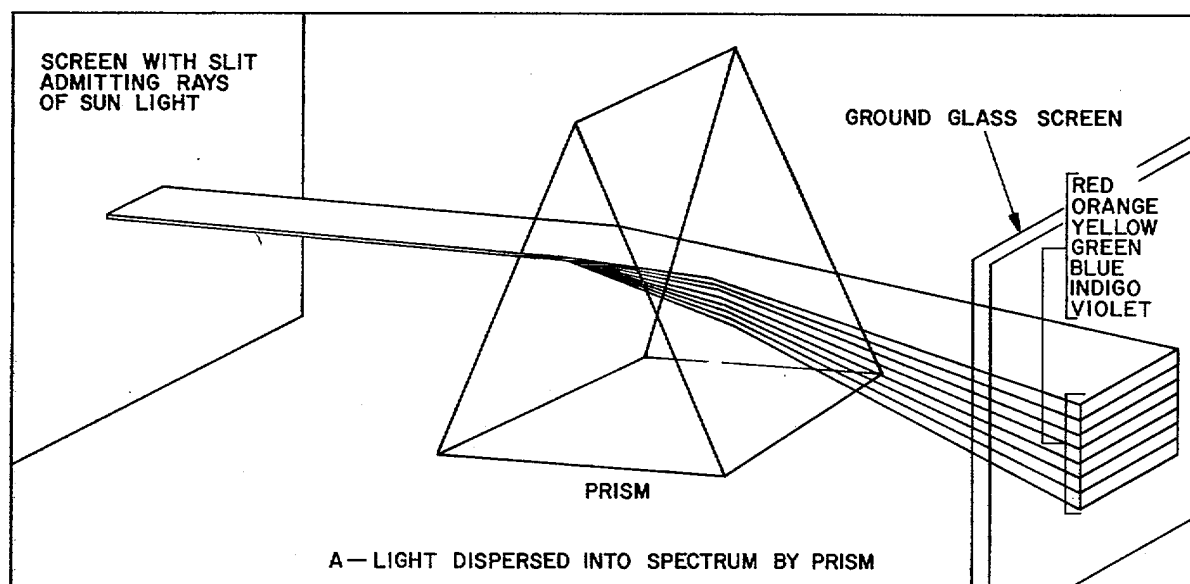

AR910057

Figure 2-51. Dispersion.

c. Glass of various optical densities disperses light to different degrees. A prism of flint glass disperses the rays of different color more than the less optically dense crown glass. A lens would also separate light because a lens may be considered as an infinite number of prisms. The properties of different kinds of glass are employed to neutralize the dispersion of the rays of colored light in lenses and prisms, and to neutralize their tendencies to form different focal points when refracted through lenses (para 2-39).

d. The principle of dispersion is put to practical use in a scientific instrument known as the spectroscope. This instrument is especially designed to disperse light coming from an incandescent source. Since any element upon being

heated to a point of incandescence emits light of a frequency unique to that element, the spectrum of an incandescent solid can be used to show of what that solid is composed. By the use of the spectroscope, helium was discovered in the atmosphere of the sun before it was discovered on earth.

e. An instrument similar to the spectroscope but fitted with a camera permits the photographing of spectra. The photographic records made by this instrument are called spectrographs. This instrument is also used to measure refractive indices and is extremely accurate.

f. The rainbow is a natural phenomenon resulting from refraction and total internal reflection of sunlight in raindrops (B, fig 2-51).



**2-28. Selective Reflection and Absorption.**

a. Objects derive their color from the selective reflection and selective absorption of light. If an object reflects practically all of the light striking it, the object appears white. If it absorbs the greatest percentage of light, it appears black. The surfaces of most objects absorb light of certain frequencies and reflect light of other frequencies. The colors of these surfaces are determined by the frequencies they reflect. This is known as *selective*

*reflection.*

b. An object appears to be of a color because it absorbs light of certain wavelengths and reflects others striking it. In sunlight, it may appear to be of one color because it reflects the light of that color and absorbs all others. Under a single color or monochromatic light, it might appear to be of another color or almost black, depending upon what colors and how much light it reflected.

**Section VI. CHARACTERISTICS OF OPTICAL SYSTEMS**

**2-29. General.** Military fire-control instruments employing optical systems are required for a great variety of purposes. To cite a few, these instruments are used to see at great distances, to magnify small objects, to determine positions, to gage distance, and to aim weapons.

**2-30. Military Telescopes.** Necessary characteristics of military optical instruments are usually the following a minimum of weight and bulk, the largest possible field of view and brightness of image consistent with the necessary magnifying power; freedom from distortion; and a combination of ruggedness with simplicity. The instrument must form a normal erect image of the object. In the majority of instruments, the optical system must include a reticle pattern.

**2-31. Magnification.** Magnification of a telescope optical system depends both upon the objective and the eyelens or eyepiece. Although the

eyepiece magnifies the image formed by the objective, it cannot supply sharpness or detail lacking in the image. The shorter the focus of the eyepiece, the greater is the magnifying power.

**2-32. Field of View.**

a. The true field of view of any optical instrument is the extent (the width and height) of what can be seen at one time by looking through the instrument. The field of view is cone-shaped; it becomes wider and higher as the distance is increased from the objective. In the majority of fire-control instruments the angle of the true field of view is relatively small (para 5-25).

b. The true field is limited by the optical possibilities of the eyepiece (fig. 2-52). The maximum angle which might be imaged by the eyepiece, if it were not for a number of limiting factors, is termed the *apparent field of view* (para 5-26)

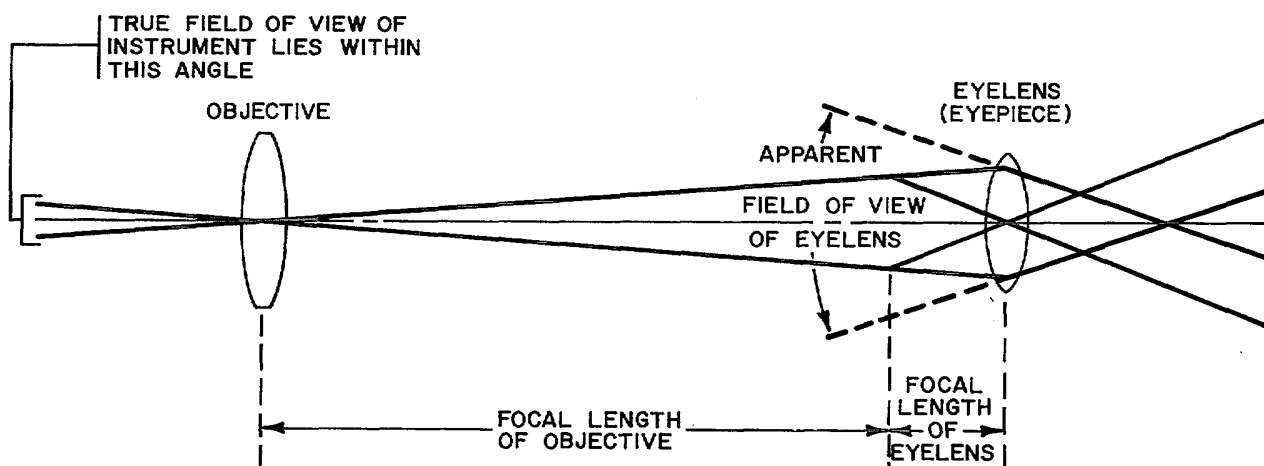

AR910058

Figure 2-52. Field of view limited by optical possibilities of eyepiece.

c. An apparent field of view of approximately 450 may be considered as a practical maximum for a highly corrected eyepiece. Thirty-five or 400 is a more common value and in the more simply constructed eyepieces the field may be only 250 or 300. This apparent field of view, divided by the power of the eyepiece, determines the maximum value of the true field for any given magnification. For example, if an eyepiece corrected for an apparent field of 400 is used and a telescope of 10-power is required, the maximum true field of the instrument would be only  $4^\circ$ .

d. Other factors can further limit this maximum true field. The components of the erecting system of the instrument might not be sufficiently large to transmit the full useful area of the image and would decrease the field. Some aperture in the instrument might be so small as to restrict the field.

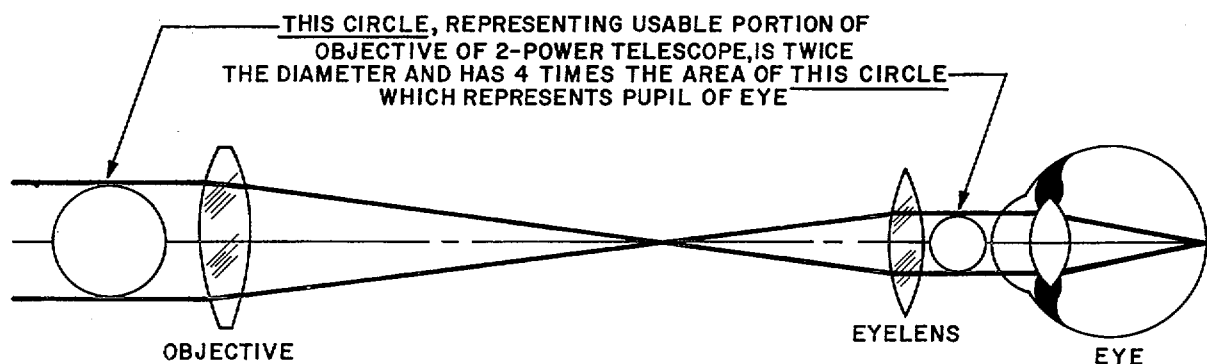

AR910059

Figure 2-53. Comparison of light entering eye with 2-power telescope.

c. Loss of Light. There is always a considerable loss of light by absorption and by reflections at the surfaces of the lenses. While this loss may be as great as 75 percent, every effort is made to reduce the loss to a minimum (para 4-13).

d. Objective Aperture. A contributing factor in brightness of image is an objective lens aperture (usable portion) large enough to permit the eyepiece to produce an emergent beam that will fill the pupil of the eye. On the other hand, enlarging the objective beyond this point affords no greater brilliance because additional light is prevented by the iris from entering the eye.

e. Exit Pupil Aperture. During the day, the pupil of the eye is from 1/10 to 2/10 inch in diameter. At night, the pupil may dilate until its

## 2-33. Brightness of Image.

a. *Brightness of Image and Exit Pupil.* The more light that can be brought from each point of the object to the eye, the brighter will be the image that is formed. This characteristic is known as brightness of image. The point where the image is brought to the eye is called the exit pupil of the instrument.

b. *Magnification and Brightness.* When one looks at very distant objects with the naked eye, almost parallel rays of light enter the pupil of the eye and form an image of a certain size on the retina. When one uses a telescope of 2-power magnification, the light forms an image on the retina which is twice as high and twice as wide or an image that covers four times the area of the image that would be formed by the naked eye of the same parts of the objects (fig 2-53).

diameter is from 1/4 to 3/10 inch. A telescope or other instrument for use at night should have an exit pupil aperture (fig. 2-54) of this size. The aperture of the objective must then be sufficiently large (1/4 to 3/10 inch times the magnification of the instrument) to insure that the pencil of light will fill the pupil of the eye. During the daytime, the useful aperture of the objective of such an instrument is correspondingly smaller.

f. *Sacrificing Brightness of Image.* Some of the telescopes used for military fire control purposes are made with objective smaller than that indicated by this formula. Brightness of image has been sacrificed to obtain a more compact instrument.

g. *Aperture Ratio of Camera Lens.* This is

the ratio of focal length to lens diameter or aperture. It is also known as the speed of a camera lens and is written as  $f/16$  (for example) or  $f/3.5$ . At  $f/16$  the lens is being used at an aperture (opening) of  $1/16$  of its focal length and at  $f/3.5$  the lens is being used at an aperture of  $1/3.5$  of its focal length. As the denominator increases, the focus becomes sharper (lessened aberration) but the light and brightness of image decrease as the aperture is smaller. The time of exposure, therefore, must be lengthened proportionally. As the denominator decreases, the lens is said to become faster (wider aperture or lens opening) and it can be used at faster shutter speeds (shorter exposure time). If it is desired to photograph action, a fast lens must be used; otherwise, the picture will be blurred from the motion.

### 2-34. Eye Distance or Eye Relief.

a. The exit pupil (fig. 2-54) is the term applied to the rays of light which emerge from any optical instrument with a collective or convergent eyepiece and form the image that is seen by the eye. The exit pupil of such an instrument can be seen as a brightly illuminated disk floating in space if the instrument is directed toward an illuminated area and its eyepiece is held about 15 inches from the eye. The position of the exit pupil can be fixed on a screen of translucent paper or on a plate of ground glass. In this manner, the distance of the exit pupil from the last glass surface of the eyepiece can be measured.

**Figure 2-54. Exit pupil.**

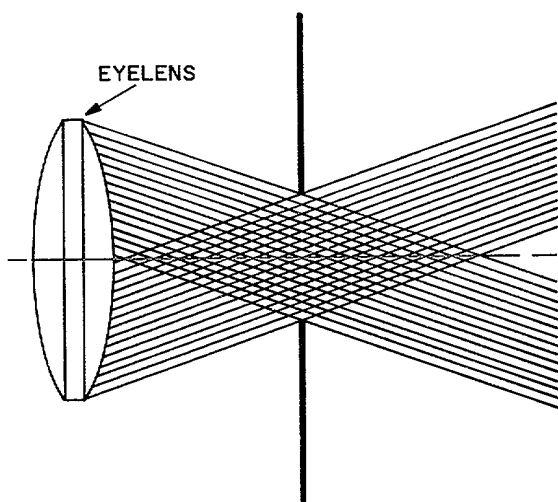

AR910060

b. The full field of view of a telescope can be seen only when the pupil of the eye of the observer is at the same position as the exit pupil. The distance from the eyelens to the exit pupil is

termed the eye distance or eye relief (fig 2-55). The eye must be placed at this distance from a collective eyepiece in order to see most effectively through the instrument.

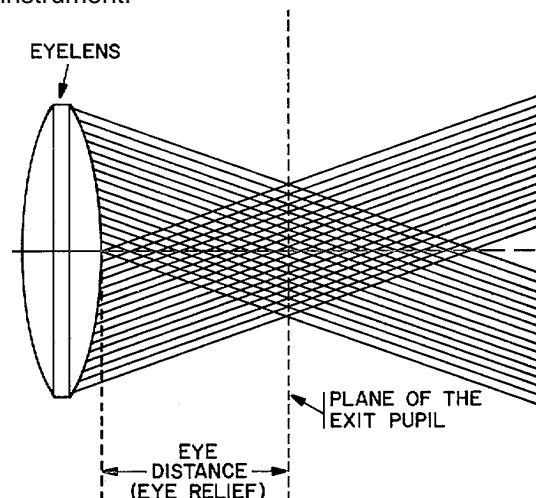

AR910061

**Figure 2-55. Eye distance.**

c. If the eye distance of an instrument is so limited that the exit pupil cannot enter the eye pupil or if the eyelashes touch the eyelens, observation through the instrument will become tiresome and the instrument cannot be used most effectively. When the instrument is to be mounted on a weapon, if the eye distance is not considerable, recoil, of the gun will make observation dangerous.

d. In the design of the instrument, the proper location of the exit pupil must be given most careful consideration. If it is too far back, the eyepiece will become too cumbersome in design; if it is placed too close, the user of the instrument will suffer discomfort and will be unable to use the instrument to the best advantage. Proper eye distance depends on the purpose for which the instrument is to be used (para 5-27).

### 2-35. Interpupillary Distance.

a. The spacing between the pupils of the eyes make stereovision possible because each eye views an object from a slightly different viewpoint. From the fused image gained from the two viewpoints, the observer receives the impression of depth. This spacing of the eye pupils varies to a considerable degree in different individuals and is known as *Interpupillary distance*. This distance is measured in millimeters by the interpupillometer M1.

b. In the designing of instruments to be used by

both eyes of an individual, provision must be made to adjust the spacing between the eyepieces of the instrument to conform to the interpupillary distance of different observers. The interpupillary distance of such instruments generally is adjustable from 58 to 72 millimeters because the eye spacing of nearly everyone is within this range. If the interpupillary distance of an individual is greater than 72 millimeters or less than 58 millimeters, he is incapable of using instruments of this type to the best advantage.

### 2-36. Focusing.

a. For perfect focusing of a monocular instrument under all conditions, two adjustments are necessary. If the instrument has a reticle, means must be provided for adjusting the distance between the reticle and the objective so that there will be no parallax (para 2-46). Also, the distance between the eyepiece and the reticle must be adjusted for the eye of the observer. In a binocular instrument, it also is necessary to adjust the instrument to conform to the interpupillary distance of the eyes of the observer.

b. If the focal length of the objective is short and the targets in general are at a great distance, the objective may be adjusted for a target at an infinite distance when the instrument is assembled in the factory and no field adjustment is provided. This is the case with some fire-control instruments and low-power telescopes.

c. Focusing eyepieces are commonly found on fire-control instruments. This adjustment is primarily designed for focusing the instrument for different eyes and is referred to as the *dioptr*

movement. The two lenses of the eyepiece are mounted in a simple tube and its distance from the reticle or focal point of the objective or erecting system can be adjusted by rack and pinion, by a simple draw tube or by rotating the entire eyepiece causing it to screw in or out.

d. On fire-control instruments a graduated scale generally is provided around the eyepiece. This scale is calibrated in diopters. The *dioptr* is the unit of measurement of the converging power of lenses (para 10-2). For a normal eye the scale on the eyepiece is set at zero. If a positive 2-diopter spectacle lens is commonly worn, the eyepiece should be set at +2 provided the spectacles are removed as they should be. After carefully focusing the instrument, the reading of the eyepiece should be memorized and used for future focusing.

e. Low-power telescopes are frequently made without any means for focusing. Such an instrument is termed a fixed-focus telescope. When assembled, such an instrument is often so adjusted that light from a distant source emerging from the instrument, instead of being essentially parallel, appears to diverge from a point 40 to 80 inches in front of the eyelens. A telescope so focused (approximately minus 3/4 to minus 1 diopter) is more readily adaptable to the eye of the average observer than one focused so that the rays of light are essentially parallel. Because a fixed-focus instrument is simple, it can be made entirely waterproof. However, if the power of the telescope is greater than 3.5 or 4, the accommodation of the average eye is not sufficient to permit its use.

## Section VII. ABERRATIONS AND OTHER OPTICAL DEFECTS

### 2-37. General.

a. Aberration is a lens or prism imperfection resulting in an image that is not a true reproduction of the object.

b. In designing an instrument, correction is usually made for optical defects with special attention being given to the use to which the instrument is to be put. Correction is achieved by using lenses or prisms made of two or more kinds of glass (called compound lenses or compound prisms), and by eliminating rays which would be refracted through the outer edges of lenses (called marginal rays) by equipping the instrument with diaphragms (field stops) (para 2-38 e), and a suitable eyepiece.

c. There are six general types of aberrations: spherical and chromatic aberrations, astigmatism,

coma, curvature of image, and distortion. Other factors which may affect the operation of the optical system of an instrument are resolving power, Newton's rings, light loss, and parallax.

### 2-38. Spherical Aberration.

a. Light rays refracted through a lens with spherical surfaces near its center and those refracted through the outer portion or margin do not intersect the axis at a single point. The outer rays of a convergent lens intersect the axis closer to the lens than the more central ones (fig 2-56) and the opposite is true of a convergent lens, considering the imaginary extension of the refracted rays (fig 2-57). The result is a blurred image. This fault is common to all single lenses with spherical surfaces and is termed spherical aberration.

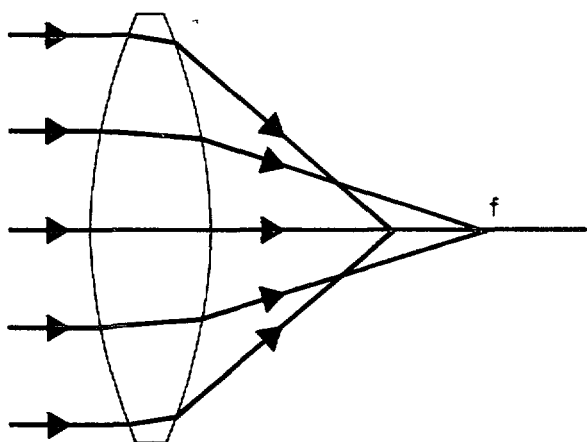

AR910062

Figure 2-56. Spherical aberration of convergent lens.

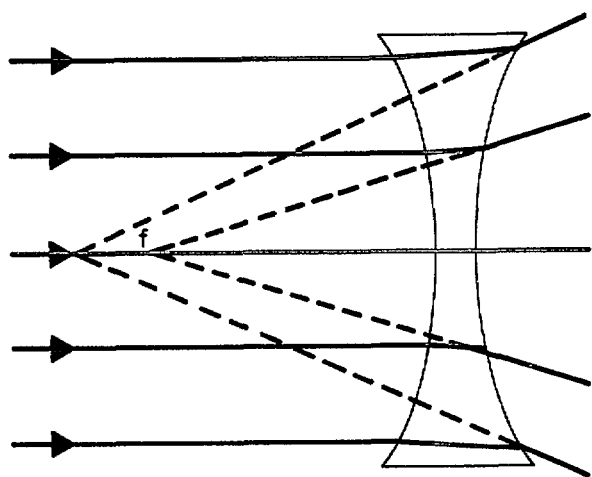

AR910063

Figure 2-57. Spherical aberration of divergent lens.

b. The thickness of a lens and its focal length influence the amount of spherical aberration. Spherical aberration is least in thin lenses of long focal length.

c. If the convergent lens were ground with constantly flattening curves to the edge instead of being ground with each refracting surface as a true portion of a sphere, the rays would be caused to cross the axis at nearly a single point and a sharp image would result. Such lenses, however, would be too difficult and costly to manufacture and would be correct for only one distance from the object. Instead, two other methods are utilized either singly or together which satisfactorily eliminate spherical aberration (f and g below).

d. Hourglass distortion, barrel distortion, and curvature of image all result from spherical aberration (para 2-42). Replacing lenses so they face the wrong way usually will introduce distortion into the system. This is of interest, therefore, to the instrument repairman.

e. In a lens system such as a complex camera objective or in a single lens used at a wide angle, spherical aberration can be reduced at the expense of light intensity by using an aperture stop, field stop, or diaphragm. The central portion of a lens is most free of spherical aberration. Tests of a lens will show how much of the area around the axis may be safely used to form a sharp image. The practice is to mask out all rays passing through the lens beyond this circle (A, fig 2-57). The mask used for this purpose is called an aperture stop. It is a flat ring or diaphragm of metal or other opaque material covering the outer portion of the lens. It stops the rays from entering the margin of the lens but, as it cuts down the effective size of the lens, it limits the amount of light passing through the lens. Obviously, in general, it would be cheaper to manufacture a smaller lens rather than to make a large lens and a stop for masking out marginal rays. Diaphragms or stops have other uses. See diaphragms or stops in paragraph 4-10.

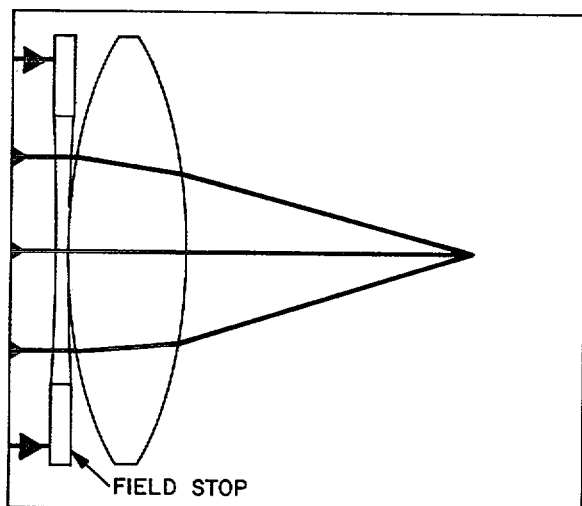

A — EFFECT OF FIELD STOP ON SPHERICAL ABERRATION

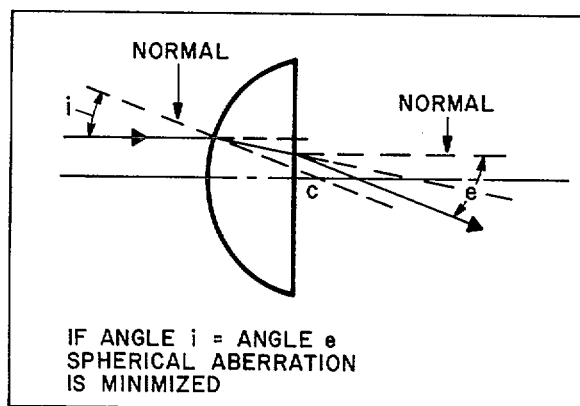

IF ANGLE  $i$  = ANGLE  $e$   
SPHERICAL ABERRATION  
IS MINIMIZED

B — SPHERICAL ABERRATION —  
REDUCTION IN TELESCOPE

AR910064

Figure 2-58. Spherical aberration reduced.

f. In fire-control instruments, spherical aberration is commonly eliminated by the use of a convergent and a divergent lens cemented together to form a single element known as a compound lens (para 4-2). The compound lens approximately corrects spherical aberration because the concave curves of the divergent lens neutralize the positive aberration of the convex curves. The refractive power of the combination is retained by the proper choice of indices of refraction for each of the two lenses. A lens in which spherical and other aberrations have been minimized or eliminated is said to be *aplanatic* (fig 2-59).

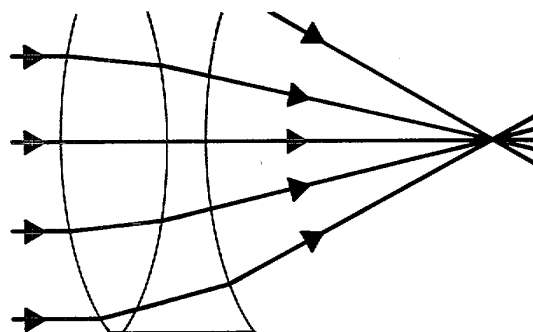

AR910065

Figure 2-59. Effect of compound lens on spherical aberration.

g. Spherical aberration is minimized by "bending" the lens. Bending is accomplished by increasing the curvature of one surface and decreasing that of the other. This tends to eliminate spherical aberration while retaining the same focal length. In telescope design, it is common practice to minimize spherical aberration in yet another way by placing the greater curvature of each lens toward the parallel rays so the deviation at each surface is nearly equal as in B, figure 2-58. The angles of incidence and emergence must be equal for minimum spherical aberration. In accord with this rule, telescope objectives always are assembled with greater curvature (the crown side) facing forward.

### 2-39. Chromatic (Color) Aberration.

a. White light consists of all colors. Upon being refracted through a prism, white light is dispersed into rays of different wavelengths forming a spectrum of various colors (para 2-27). The rays of different colors are refracted to different extents; red undergoing the least refraction and violet the most. Inasmuch as a lens may be thought of as being composed of an infinite number of prisms, this dispersion also exists where light is refracted through a lens. This produces an optical defect, present in every uncorrected single lens, known as *chromatic aberration* or *chromatism*. The violet rays focus nearer the lens than the red rays (fig 2-60) and the rays of the other colors focus at intermediate points. Thus, such a lens would have a different focal length for each color and the image would be fringed with

color. Similarly, spherical aberration is greater for blue rays than for red rays because the focal length of a lens is shorter for blue than for red rays. This is due to red rays being refracted the lesser of the two. The marginal parts of a blue real image

formed by a positive lens will show compression, while the marginal parts of a blue virtual image viewed through a positive lens will be more distended than the red rays.

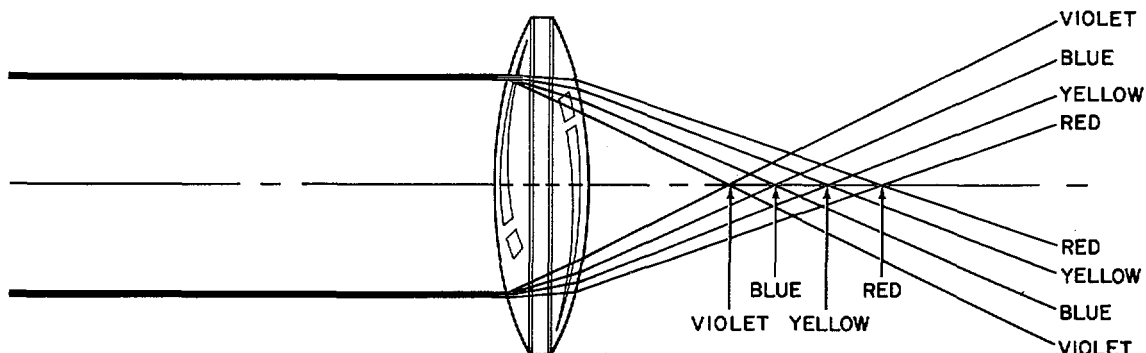
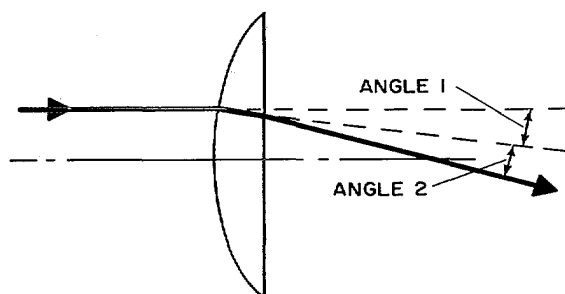

Figure 2-60. Chromatic Aberration

AR 910066

b. The aforementioned chromatic aberration, to prevent trouble in optical instruments, must be corrected by spacing between lenses and by adjusting curvatures. A, figure 2-61, illustrates the diminishing to such effects by equalizing the deviation at the two surfaces. Like spherical aberration, chromatic aberration is corrected by making a compound lens of two separate lenses; one positive (convergent) and one negative (divergent). The positive lens is made of crown glass while the negative lens is made of flint glass (B, fig 2-61). Crown glass is more strongly *convergent* for blue rays than for red, while flint glass is more strongly divergent for blue rays than for red. The high color dispersion of the flint glass negative lens is sufficient to compensate for the lower color dispersion of the crown glass positive lens without entirely neutralizing its refractive power. A compound lens so designed is said to be *achromatic*. Construction of a lens of this type is described in paragraph 4-2b.



ANGLE 1 = ANGLE 2  
FOR LEAST CHROMATIC  
ABERRATION

A - CORRECTION FOR LEAST  
CHROMATIC ABERRATION

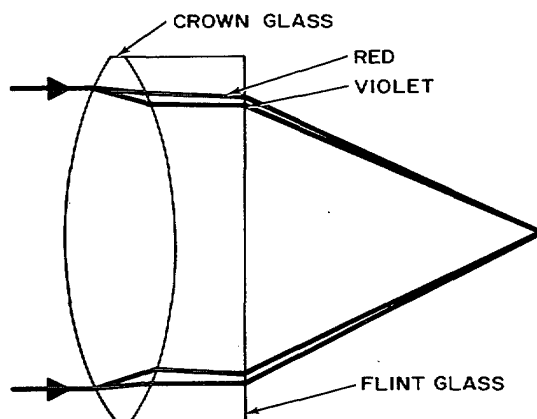

B - COMPOUND LENS

AR 910067

Figure 2-61. Correction of chromatic aberration of lens.

c. Spherical and chromatic aberrations usually are corrected by the same two elements of a compound lens. In some lenses, the negative element is planoconcave (only one surface ground spherically). In this case, the adjacent surfaces are ground to compensate for these two defects. In others, the inner curves of the lenses are calculated to eliminate chromatic aberration and the outer curves to remove spherical and other types of aberration.

d. The majority of prisms employed in fire-control equipment are used to reflect light; some are used to refract light. When light is reflected by a prism, there is no chromatic aberration because the light rays are not divided up or dispersed. Only when light is refracted by a prism, as through a measuring wedge of a range

finder, is the light affected by chromatic aberration.

e. Chromatic aberration in a refracting prism is corrected in much the same manner that it is in a lens. Two prisms made of different kinds of glass are cemented together (fig 2-62). The prism having the larger refracting angle and which is to be the means of refracting light from its normal path is made of crown glass. The prism having the smaller refracting angle is made of heavy flint glass which has a large dispersion of colors. The flint prism, by reason of its large dispersion, neutralizes the dispersion caused by the crown prism without entirely neutralizing the deviation of the path of light. This compound prism is known as an *achromatic prism*.

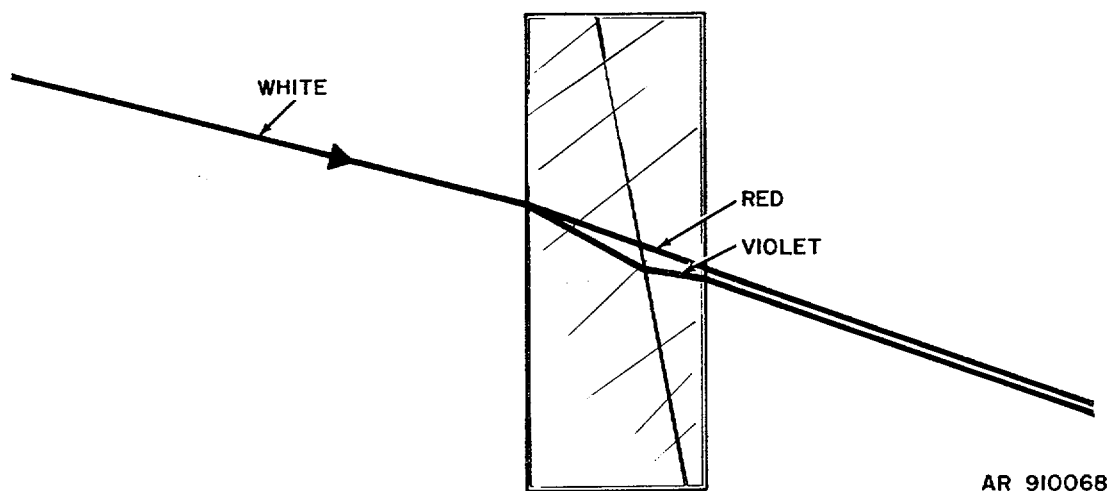

Figure 2-62. Correction of chromatic aberration of prisms.

#### 2-40. Astigmatism in Lenses.

a. Astigmatism is a lens aberration which makes it impossible to get images of lines equally sharp when these lines run at angles to one another. This optical defect is found in practically all but relatively complex lenses known as *anastigmats* which are designed to practically eliminate this condition.

b. A perfect lens refracts rays from a point of light to a sharply defined point of light on the image. The useful rays which form the image are refracted as a cone (fig 2-63). Each cross section of one of these cones is circular in form; each successive circle becoming smaller until the focal point is reached



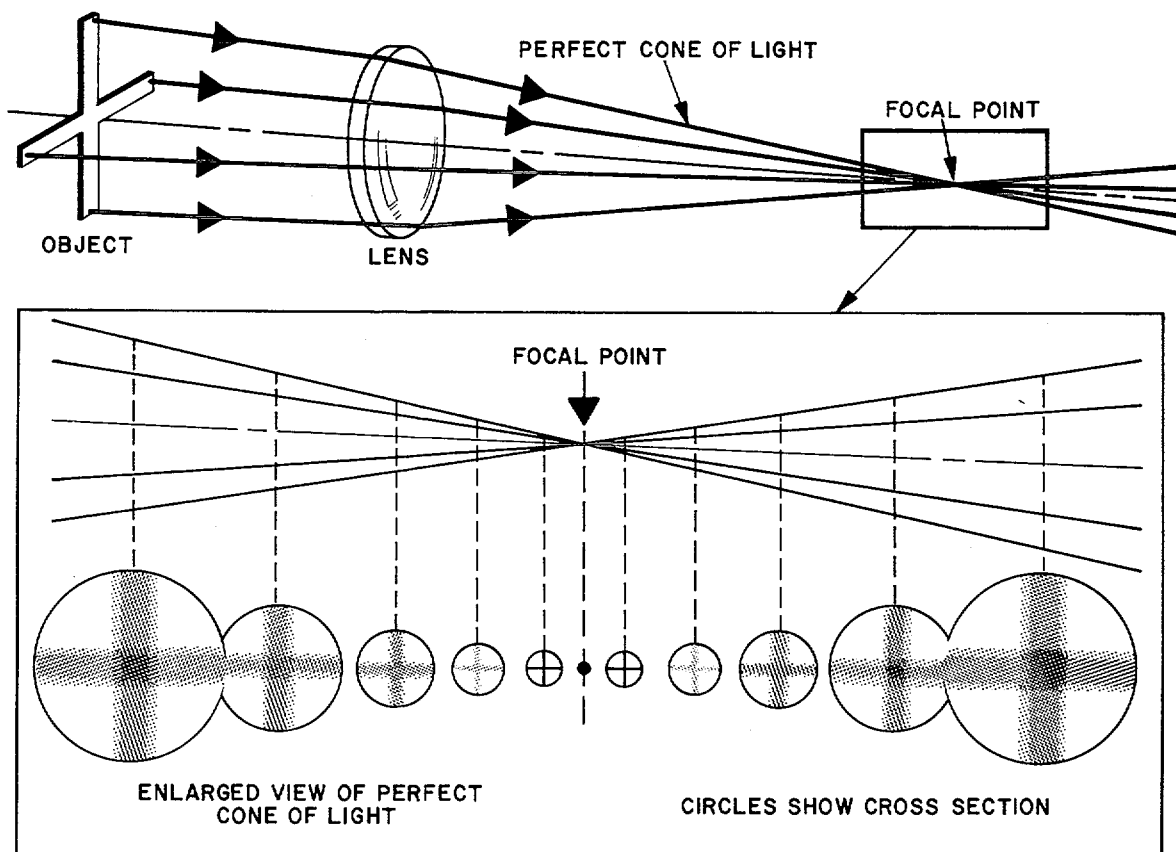

AR910069

Figure 2-63. Proper refraction of light .

c. A lens with spherical or plane faces properly ground will not show astigmatism for points near the axis but will show astigmatism for points laying at a considerable distance from the axis. The face of the lens is then presented obliquely to the incoming light rays. Cross sections of the cone of light refracted by the lens become successively narrow ovals until they become a line in the

vertical focal plane; then they become broader ovals until they are circular; and then they again become a line in the horizontal focal plane at right angles to the first line (fig 2-64). Between the two focal planes is an area known as the *circle of least confusion*. It is in this plane that the most satisfactory image is secured.

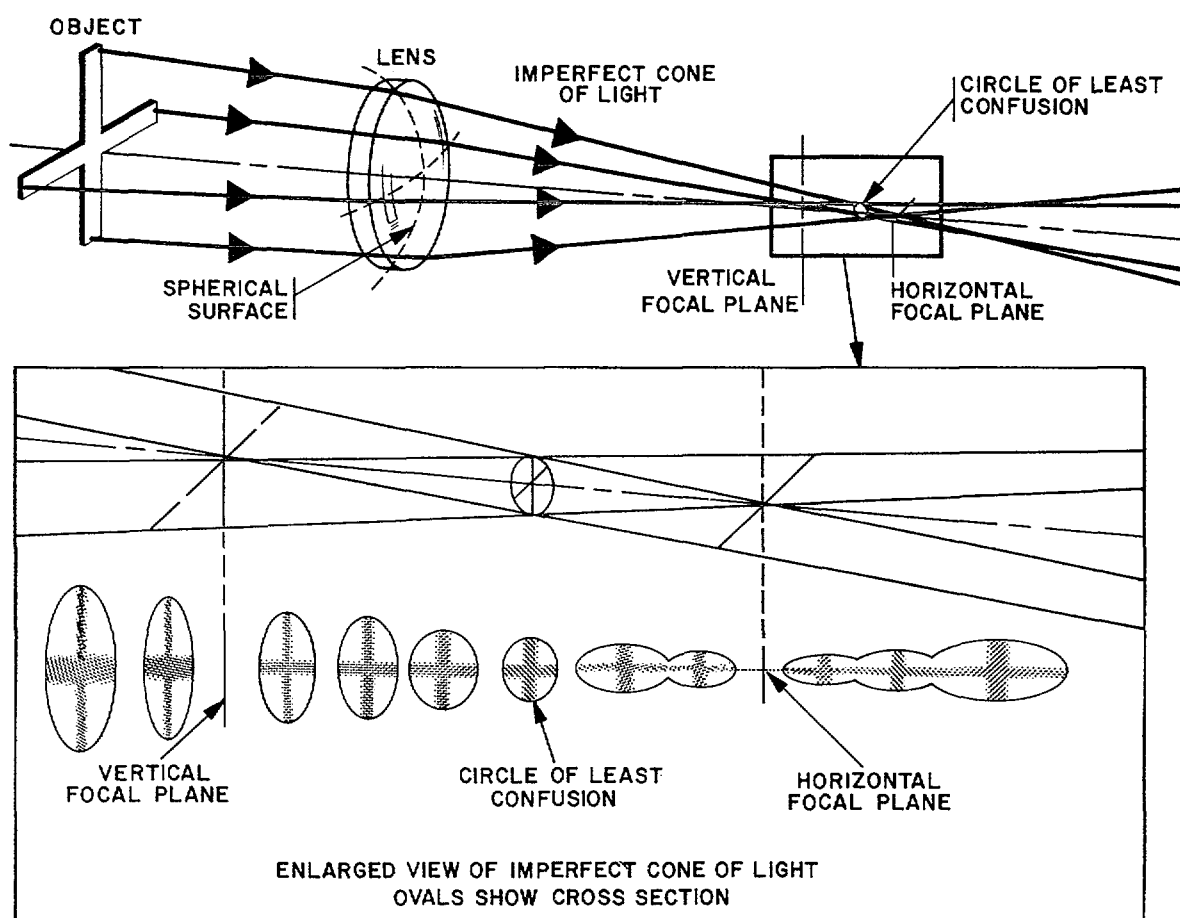

AR910070

Figure 2-64. Astigmatic refraction of light .

d. Astigmatism is reduced to acceptable quality by the use of several lenses in the same manner as spherical and other aberrations. Lenses are made of optical glasses possessing different degrees of refraction, ground to different curvatures, so that the aberrations of all types cancel each other.

#### 2-41. Coma.

a. Coma is due to unequal refracting power of the various zones or concentric ring surfaces of a lens for rays of light coming from a point which lies a distance off the axis. It is caused by the rays from the various zones coming to a focus at slightly different points so that they are not exactly superimposed. It appears as blurring of the images for points off the axis.

b. The image of a point of light is formed by a cone of useful light rays refracted through a

relatively wide portion of a lens. The lens may be considered to be divided into concentric circular zones or rings of varying thickness. To form a sharply defined point of light, the rays from each zone must come to a focus at exactly the same place in the focal plane.

c. In a lens producing coma, rays of light originating at a point located off the axis and refracted through the inner zone form a well defined image of the point. Rays refracted through the next zone form a larger, less-defined image of the point which is offset slightly from the first. The image formed by each successive zone is larger, less defined, and farther removed from the initial point of light (fig 2-65). The displacement of the successive images is in a direction toward or away from the center of the field of the lens.

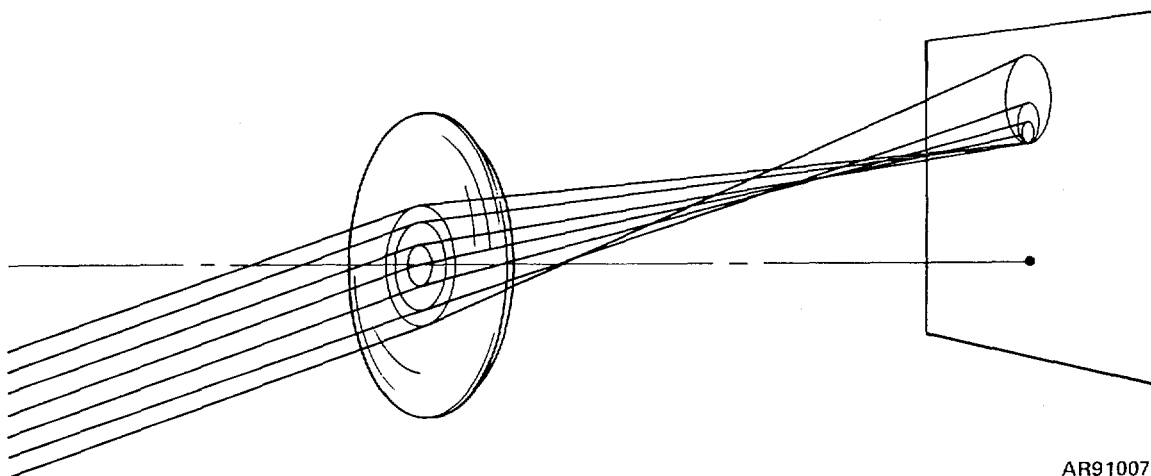

AR910071

Figure 2-65. Coma

d. The total image of the point offset from the axis may be any of a wide variety of patterns, an egg-1, pear-, coma-, or comet-shaped blur (fig 2-66). Its general appearance of a comet gives it the name of coma. When viewed under a microscope, a point of light influenced by coma may have a very fantastic shape due to its being affected at one time by all types of aberrations. Inasmuch as coma causes portions of points of light to overlap others, the result is blurred images of objects in the portion of the field affected by coma.

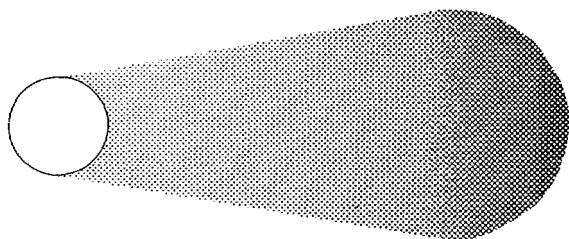

AR910072

Figure 2-66. Appearance of coma greatly magnified

e. In producing compound lenses the several types of glass and the curves of the various faces are carefully chosen to give approximate correction for coma as well as for other aberrations. Aplanatics are lenses corrected for spherical, coma and chromatic aberration.

#### 2-42. Curvature of Image and Distortion.

a. *Definition of Distortion.* Distortion is a form of spherical aberration in which the relative location of the images of different points of the object is incorrect. When imaged by a lens having this defect, a straight line extending across the field is curved. This is a serious defect in instruments of high magnifying power because the amount of distortion present is increased in proportion to the power of the instrument.

b. *Causes of Distortion.* Distortion (fig. 2-67) is particularly harmful when the object is held in close proximity to lens and is caused by rays of light from different points of the object being refracted by dissimilar portions of a lens. When a line extends across the field, is located close to lens, and is off clear, rays from the middle of the line strike the lens nearer its center. These rays are refracted at a different angle from that of rays striking near the margin of the lens, giving a curved instead of straight appearance to the image.

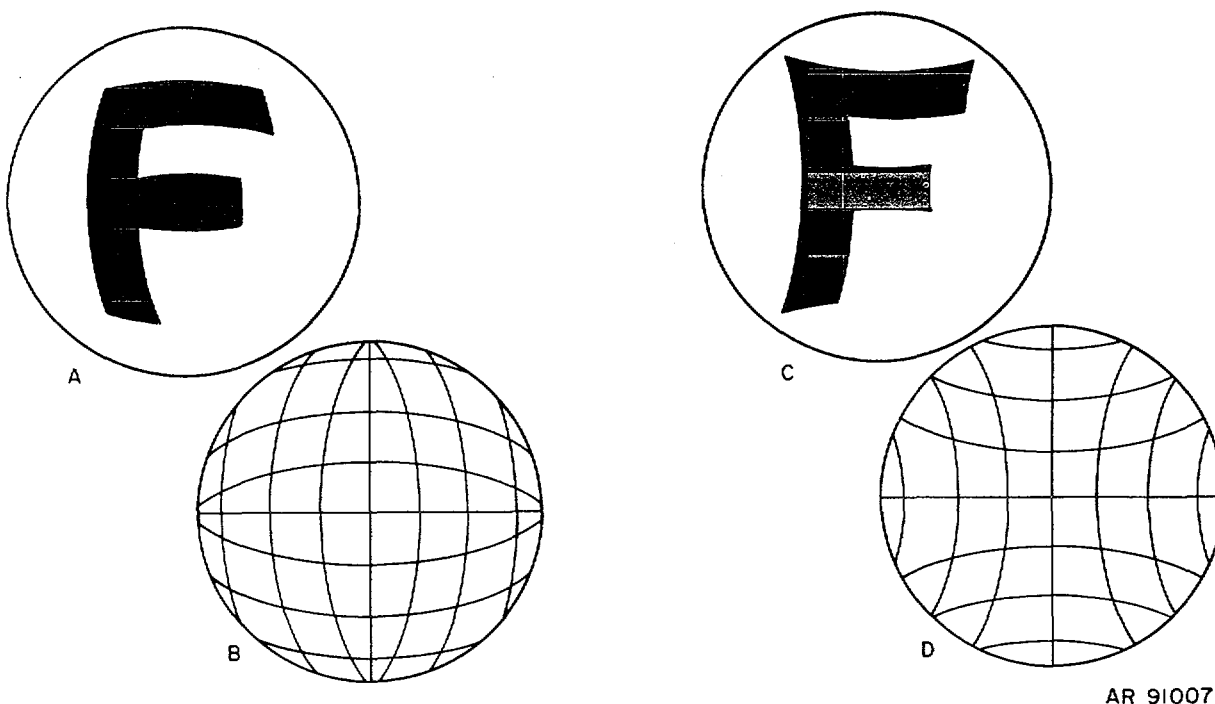

AR 910073

Figure 2-67. Barrel-shaped (A and B and hourglass (C and D) distortion .

c. Forms of Distortion. If the curvature of the lines of the image is away from the center of the lens, the distortion is termed barrel-shaped (A and B, fig 2-67). If the lines curve toward the center, the distortion is called *hourglass or pincushion* (C and D, fig 2-67).

d. *Curvature of the Image*. The field of a lens is the area in which the image produced by the lens

is formed. This area should be flat in order to form an undistorted image. When it is not flat, but is concave or saucer-shaped, the condition is termed curvature of the image or curvature of the field. An ordinary reading glass plainly shows curvature of the image (fig 2-68). In fire-control equipment this defect causes distortion in portions of the field located a distance off the axis.

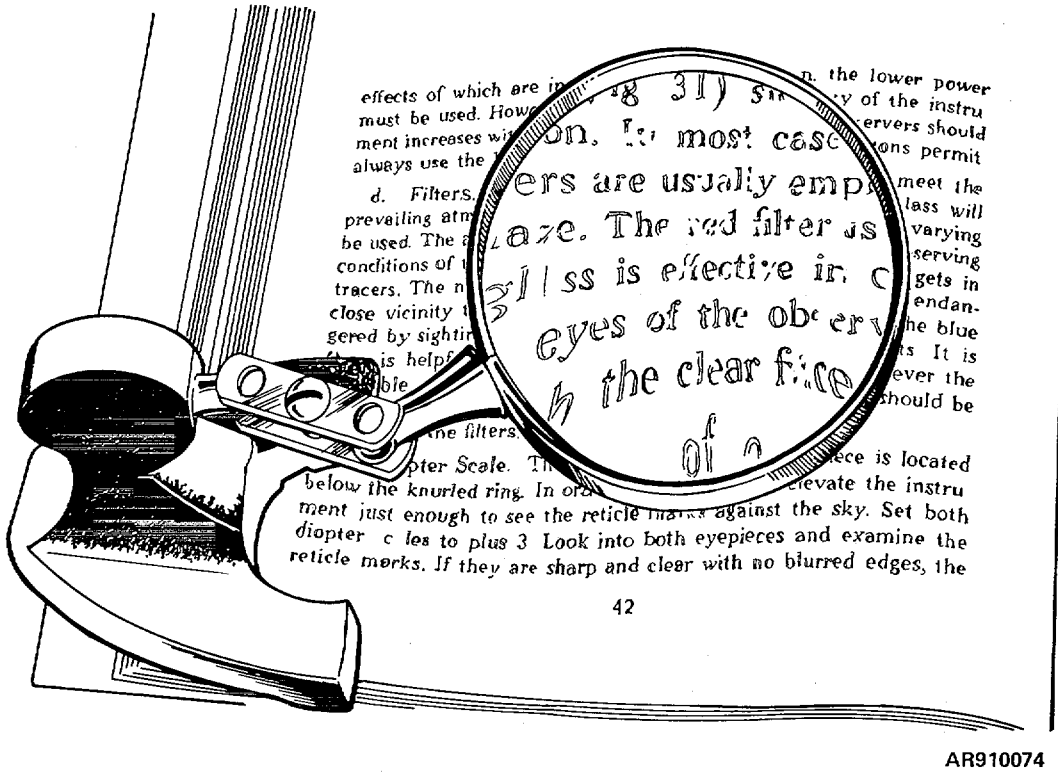
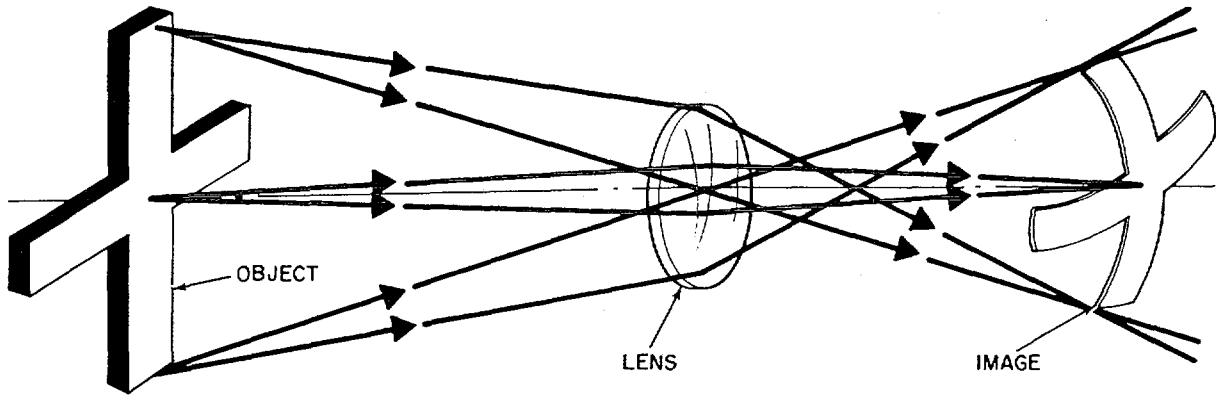

Figure 2-68. Hourglass distortion in magnification by reading glass .

e. *Formation of Image Curvature.* Curvature of the image is readily visualized by assuming that a cross is imaged by a lens with this defect (A, fig 2-69). Rays from points of light at the ends of the arms of the cross are brought into focus nearer the lens than rays from the center of the cross. If the

lens is focused on the center of the cross, the ends of the arms are not \_ sharp focus and vice versa. This is particularly disadvantageous in a photographic lens where a flat plate or film is used. If the image is to be in focus over the entire plate, the image also should be flat.



A - CURVATURE OF REAL IMAGE

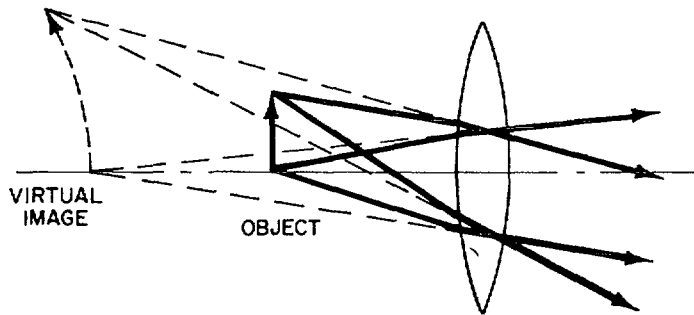

B - CURVATURE OF VIRTUAL IMAGE

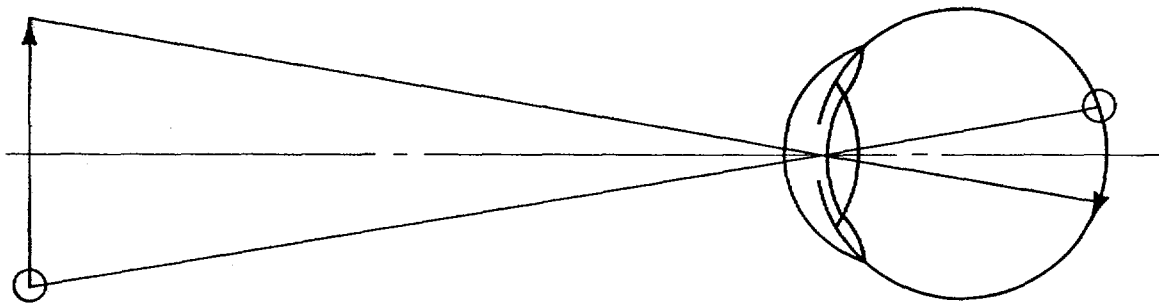

C - CURVATURE OF IMAGE IN EYE

AR 910075

Figure 2-69. Curvature of image .

f. *Rays and Pencils.* A definition of eccentric and paraxial rays and of centric, eccentric, and paraxial pencils will clarify curvature of image in spherical aberration. Eccentric rays are rim rays which pass through a lens remote from its center. Paraxial rays are those along the axis of the lens. Oblique centric pencils are cones of light which pass through the center of a lens at a considerable angle to the principal axis. Paraxial pencils are

those along the axis. Eccentric pencils are those which pass through the lens near the rim, remote from its center.

g. *Hourglass Distortion.* Paraxial magnification of a convergent lens (magnification through the lens near the optical axis) is actually less than the true magnification of the lens. Spherical aberration thus appears as hourglass or pincushion distortion when a virtual image is viewed through an un

corrected lens as in C and D, figure 2-67. The extremities of such a virtual image will be curved away from the lens so that we call this phenomenon curvature of image as in B, figure 2-69.

*h. Barrel Distortion.* Eccentric rays refracted more by a convergent lens and cross the axis closer to the lens than paraxial rays. Oblique centric pencils also focus closer to the lens than paraxial pencils. As the real image is formed where the eccentric pencils and the centric pencils come to a focus, it is obvious that such an image formed by an uncorrected convergent lens will be curved with the extremities of the image close to the lens as in A, figure 2-69. This curvature of image is especially troublesome in wide-angle instruments. This image on a screen will present barrel distortion (A and B, fig 2-67) and it will be impossible to focus all the image clearly at one time on the screen. On a screen of the same curvature as that of the image, no distortion or out-of-focus effect would appear. The human eye used such a screen as in C, figure 2-69.

*i. Correction for Distortion and Curvature of Image.* Distortion or curvature of image is partially corrected by employing a compound lens, consisting of one convergent and one divergent lens, the two having different types of distortion. In certain cases, field stops or diaphragms may also be used to restrict the passage of undesired marginal rays. A highly corrected distortion-free eyepiece or lens system is called *orthoscopic*; it gives an image in correct normal proportions and

gives a flat field of view.

### 2-43. Resolving Power of Lens.

*a.* When two points viewed through a lens are so close together that they cannot be distinguished as two distinct points, these points are not resolved. To make separation of such points possible, a lens of greater resolving power is required. The measure of the resolving power of a lens is the limiting angle of resolution which is the angle subtended at the optical center of the lens by two points which are close together and can be just barely distinguished as two distinct separate points.

*b.* It might be supposed that a point of light on the object on being refracted through a high quality compound lens would form a single point of light on the image. However, a factor termed diffraction tends to enlarge the point of light so that it merges with another point close to it.

(1) Diffraction causes the image of a point of light to become a tiny disk of light surrounded by a series of concentric rings of light which rapidly fall off in intensity, a minute bull's-eye target of light. This can be demonstrated to the best advantage by sharply focusing the lens on a very small single point of light. The image, if it were greatly magnified, would resemble a series of concentric rings (fig 2-70). The images of more detailed objects are made up of these tiny bullseyes.

(2) Diffraction sets the final limit to the sharpness of the image formed by a lens.

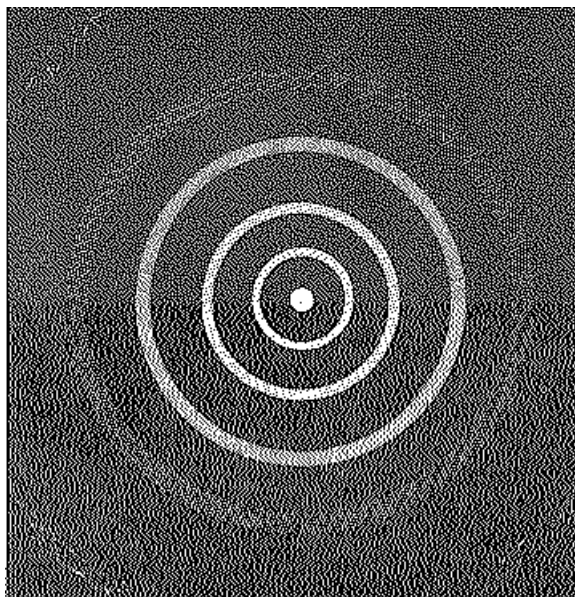
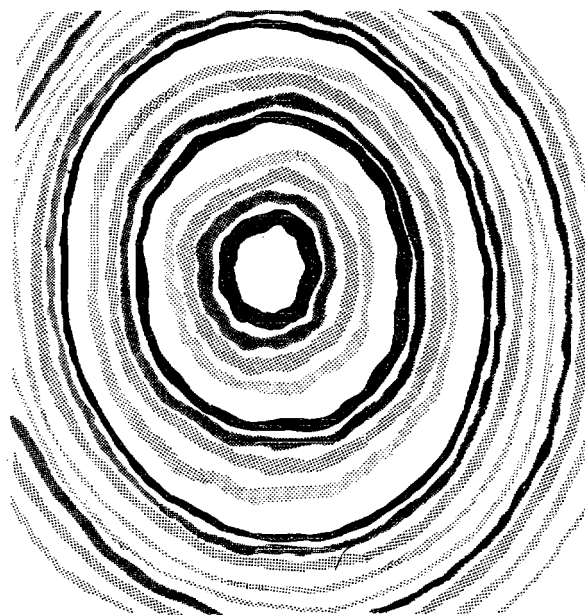

Figure 2-70. Diffraction pattern, greatly magnified .

c. In practice, the resolving power of a lens selected for a specific purpose is usually so great that any lack of sharpness of detail is too slight to be observed and, therefore, too slight to be objectionable in the performance of the service for which the lens is intended.

#### 2-44. Newton's Rings.

a. When position (convergent) and negative (divergent) lenses of slightly unequal curvature are pressed one against the other, irregular bands or patches of color appear between the surfaces. This pattern is called *Newton's rings* (fig 2-71) after Sir Issac Newton who directed attention to it. This condition is a defect if it occurs in a compound lens. It may be utilized to advantage as a means for testing the accuracy of grinding and polishing lenses.



AR910077

Figure 2-71. Newton's rings .



*b.* When testing lenses for accuracy of grinding and polishing, a test lens having the desired curvature is used. The test lens is placed in contact with the lens to be tested, care being taken that both surfaces are perfectly clean and dry. When the lenses have been squeezed together, if the lens being tested is perfect, the air film between the two lenses will be of uniform thickness and the color will be uniform all over the surface. Irregular bands or patches of color show that the surface of the tested lens is not perfect and point out clearly the parts of the lens needing attention.

#### **2-45. Light Loss.**

*a.* Whenever light rays strike the surface of any lens or prism, a certain amount of light is lost by absorption and reflection. Light is absorbed by every element it strikes or travels through. The more elements in the optical system, the more light is lost by absorption and reflection.

*b.* Light loss by reflection from surfaces has been greatly reduced by coating the surfaces of elements which are intended only to refract light (paras 4-13 thru 4-16). The additional light transmitted by instruments in which various

elements have been coated produces brighter, effective images.

#### **2-46. Parallax.**

*a.* Parallax is apparent displacement of one object with respect to another due to the observer's change of position (A, fig 2-72).

*b.* Parallax in a telescope sight is observed as a relative displacement (apparent movement) between the reticle and the field of view. Parallax is present when the reticle is displaced from the image plane; in other words, it is present when the image is not formed at the reticle but is located either in front of or behind the reticle as in B, figure 2-72. Parallax can be eliminated either by moving the objective lens, thus shifting the image, or by moving the reticle to coincide with the image. In a high-power instrument (above 4X), it is necessary to provide means of moving the objective to eliminate parallax if the instrument is to be used at all ranges, for example, from 50 feet to infinity. The engineer's transit has such an objective-focusing device as do all target-type telescopic sights used on rifles.

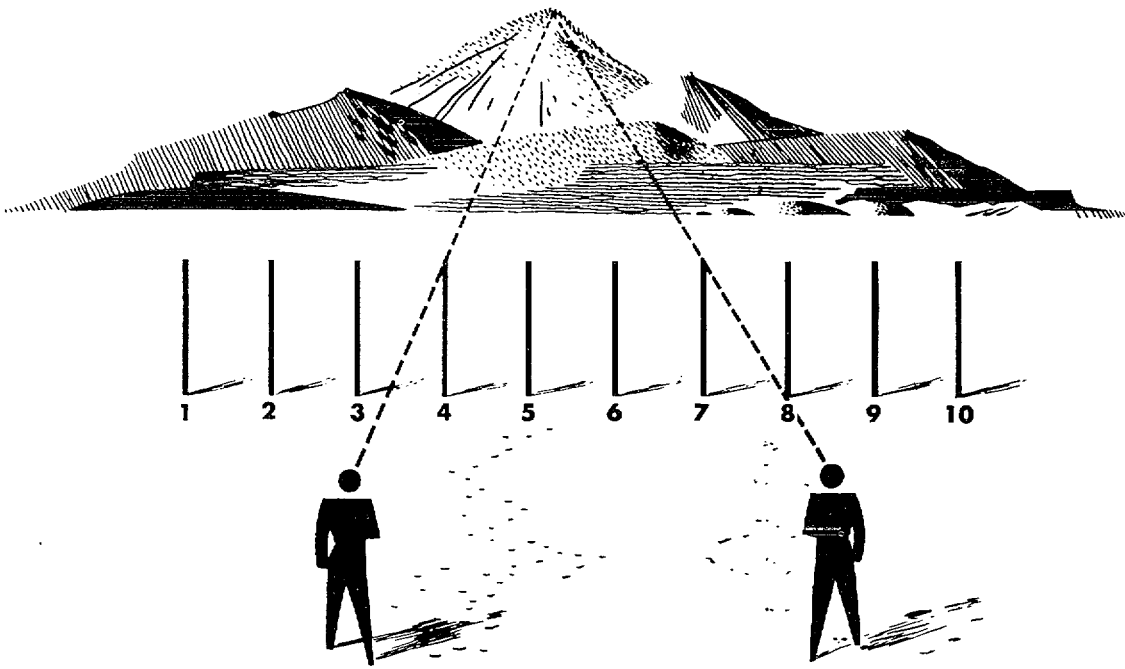

A—DEMONSTRATION OF PARALLAX

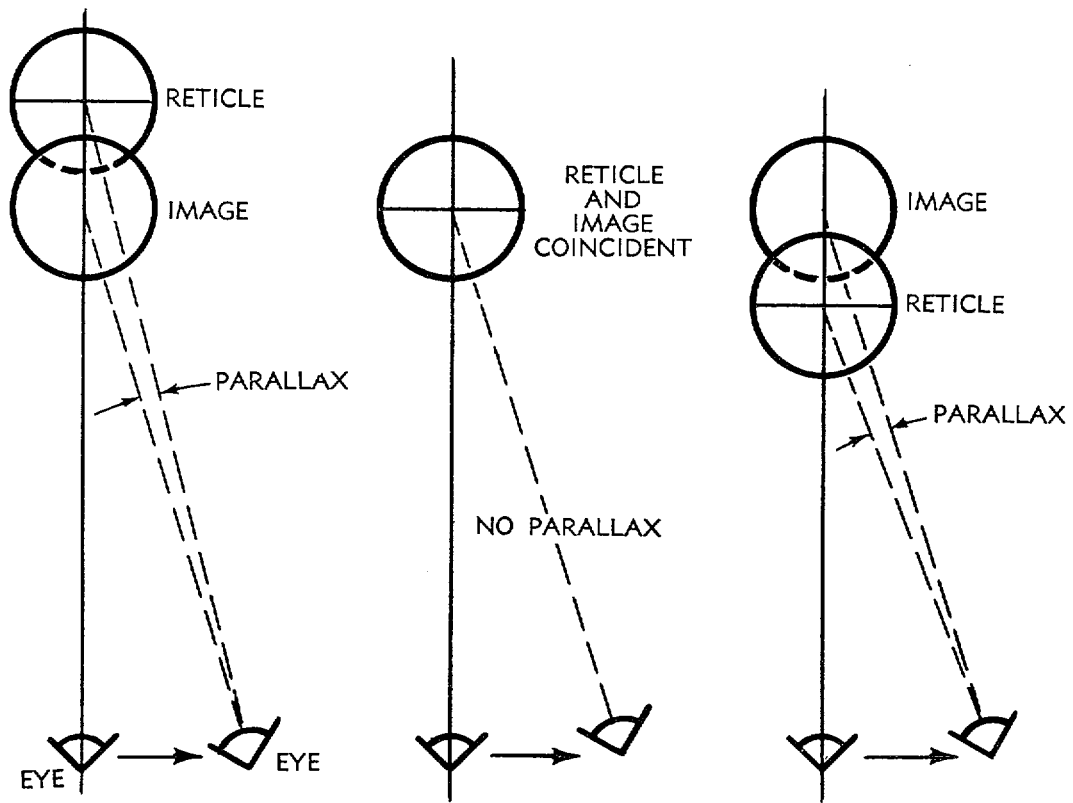

B—PARALLAX IN TELESCOPIC SIGHT

AR910078

Figure 2-72. Parallax

## CHAPTER 3

### THE HUMAN EYE

#### Section I. GENERAL

**3-1. Introduction.** All creatures endowed with sight have eyes of some sort; some are simple and others complex, some adapted to long range vision and others to short distances. Animals and birds of the mountains and plains, where vision is unobstructed for great distances, have visual ability which enables them to pick out objects too small for human perception. This ability appears to be associated with small nerve endings in the retina, faster retinal response to observed motion, and better interpretation by the brain. The other extreme is represented by the short range compound eye as found in insects and crabs. This arrangement consists of a patchwork of individual "eyes," each of which records a spot of shade or

light, and response of the whole patchwork makes a rough image but is coarse and inefficient in making visible any details of the outline in pattern resolution.

**3-2. Comparison of Eye and Camera.** The human eye, which is rather a sturdy organ of wonderful design, may be called a living automatic camera. A high-grade camera closely resembles the eye in basic essentials. Each has a compound lens to refract light rays and to project them to definite points by focusing. Each has a diaphragm to regulate the entering light, a sensitized surface to receive and record optical images, and a lightproof chamber to shut out extraneous light and to protect the receiving and recording mediums (fig 3-1).

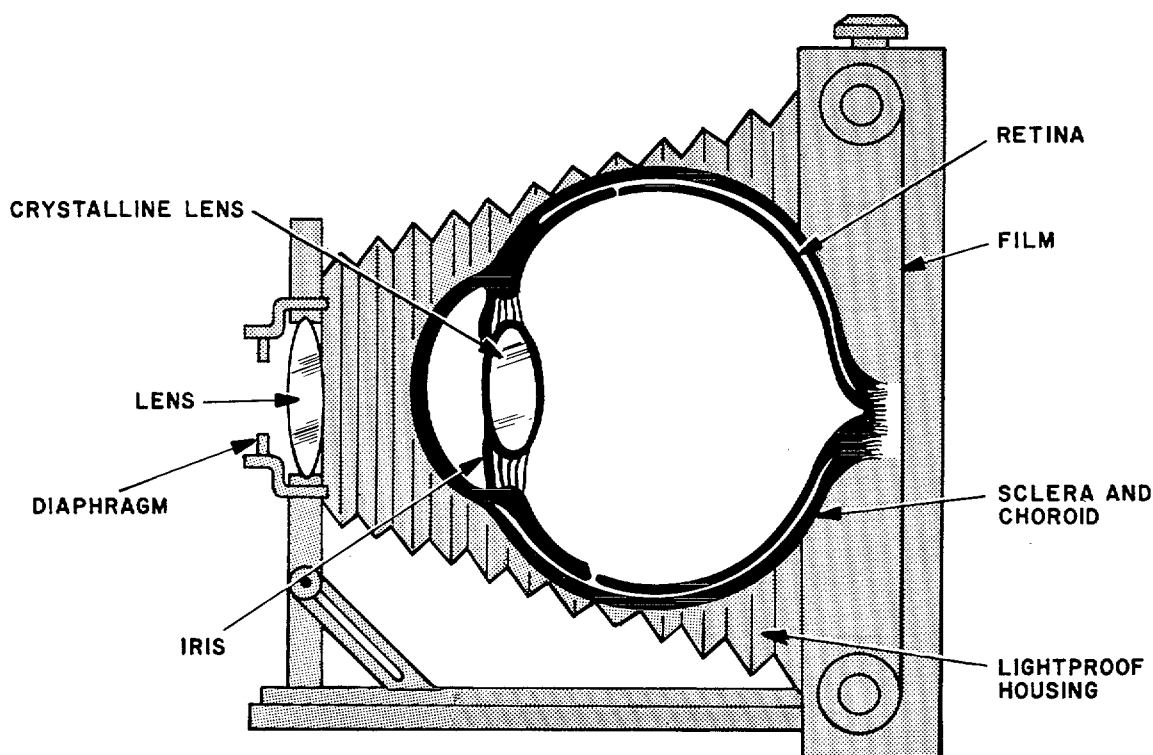

AR910079

Figure 3-1. Comparison of eye and camera .

## Section II. CONSTRUCTION

**3-3. Structure of the Eye.**

a. The eye is an organ nearly spherical in shape, approximately an inch in diameter which rotates through quite a wide range in a socket in the bone structure of the head. Muscles control the eyes in associated movements to a considerable extent and in individual movement to a lesser degree. Protection and shade are furnished by the eyelids, lashes, brows, and by the configuration of bones.

b. The eye has three coats which afford it

protection, supply it with nutrition, shut out extraneous light, and transmit visual impressions to the brain (fig 3-2). It has a refracting mechanism consisting of the crystalline lens, cornea, aqueous humor, and vitreous humor; together, these form a compound lens. The shape of the lens is changed by the ciliary muscles which serve to change the focus of the lens. The iris serves as a diaphragm to regulate the amount of incoming light

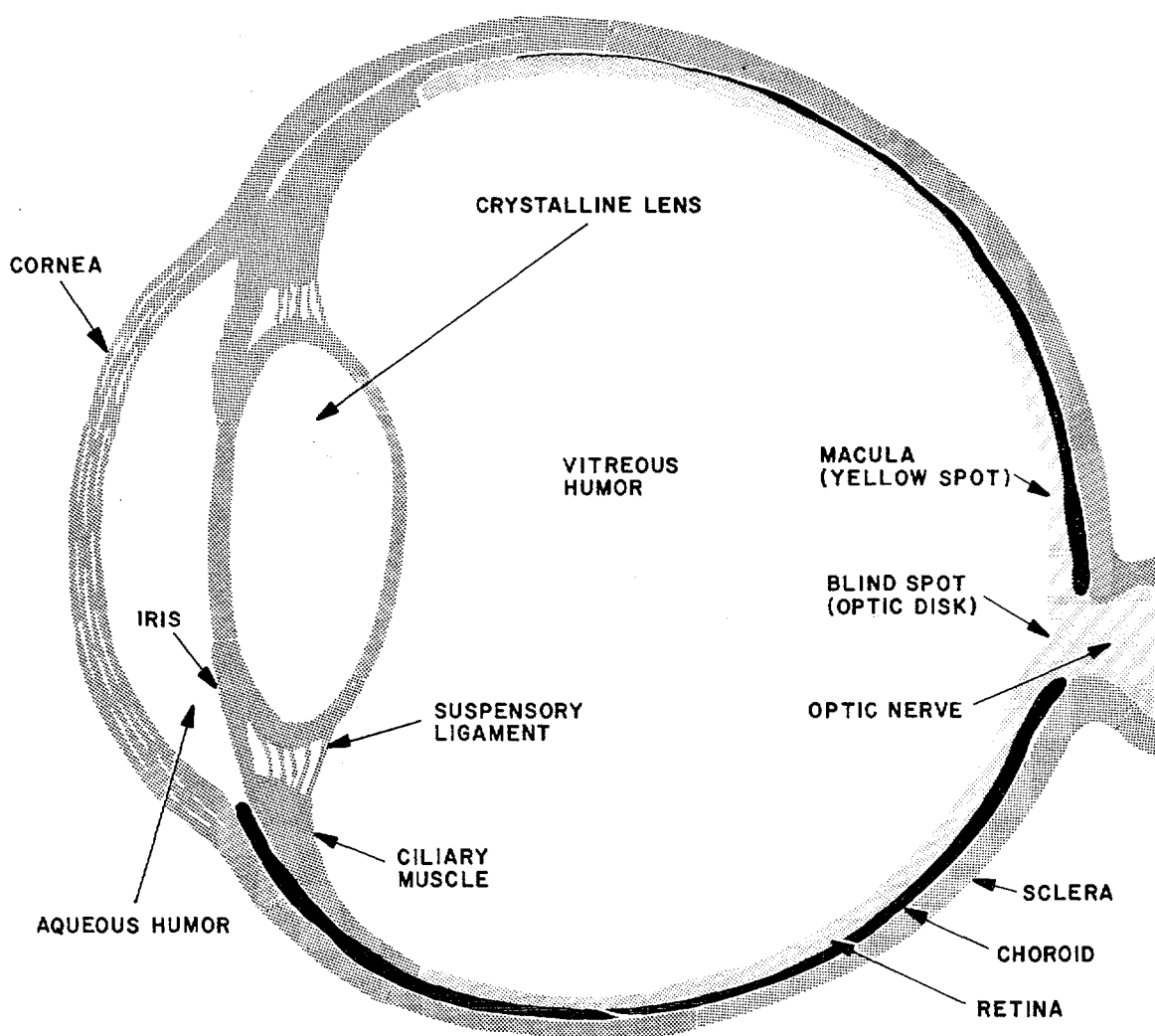

AR910080

Figure 3-2. Cross section of eyeball .

c. The clearest and most distinct vision of the response mechanism of the eye is centered in a small area called the *macula* or yellow spot on the inner coat or retina and in a still more sensitive smaller spot in the center of the macula called the *fovea or fovea centralis*. Sensations of light are received by tiny cones and rods attached to nerves and distributed over the fovea, macula, and retina. These sensations are transmitted to the brain by the optic nerve at the lower rear of the eyeball.

### 3-4. Three Coats or Tunics.

a. The outer of the three coats or tunics of the eye is the sclera (fig 3-2) to which are attached the six muscles that hold the eye in place. It is tough, white, and flexible and is the white portion of the eye normally seen. The slightly protruding tough transparent portion at the center front of the eye, the cornea, is part of this coat. The cornea and the transparent liquid or aqueous humor behind it are part of the refracting mechanism of the eye. The *aqueous humor* is essentially a weak salt solution.

b. The middle coat, the choroid, is a deep purple layer made up of veins and blood vessels which supplies nourishment to the eye tissues. The coloring of the choroid forms a dark housing and prevents external light from diffusing into the eye through the walls of the eyeball.

c. The inmost coat of the eye is the *retina*, a highly sensitive layer of nerve fibres by means of which visual impressions are transmitted to the brain. The retina is a part of the response mechanism. The interior of the eye is filled with a

thin jelly-like substance, the vitreous humor, which is transparent.

d. Light entering the eye passes successively through the cornea, the aqueous-humor, the crystalline lens, the vitreous humor, and falls on the retina.

### 3-5. Refracting Mechanism.

a. The chief refracting surfaces of the eye are those of the cornea and the crystalline lens. The cornea provides the constant portion of the refraction. The crystalline lens supplies a variable degree of refraction which permits the eye to focus on near or distant objects. This gives to the eyes the ability to see far or near objects distinctly and is termed the power of accommodation.

b. The iris is a diaphragm which contracts and dilates to regulate the amount of light entering the eye (fig 3-3). The iris is the variously colored portion of the eye around the pupil. The pupil is the circular opening in the center of the iris. Its size is limited by the contraction or dilation of the iris. It appears black because of the comparative darkness of the inside of the eyeball. The pupil varies in size from 2 to 8 millimeters, depending upon the illumination. In intense illumination, the iris steps the pupil down to about 2 millimeters. In moderate (daytime) illumination, the opening is about 4 or 5 millimeters. This is considered to be the opening for maximal acuity or best resolution. In very faint (night) illumination, the diameter of the pupil is approximately 8 millimeters

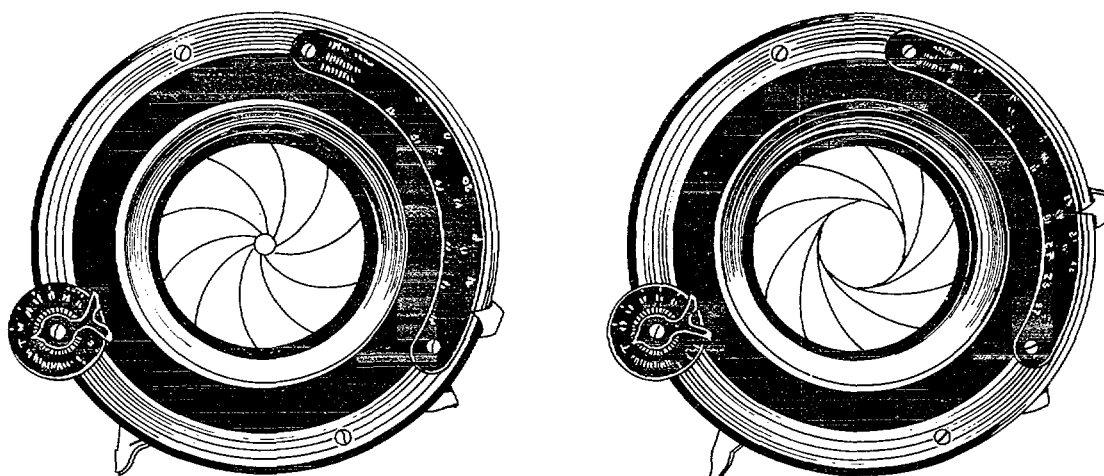

AR910081

Figure 3-3. Action of iris compared with camera diaphragm .

c. The crystalline lens is transparent and is suspended by the ligaments and muscles of the *ciliary body* which encircles it (A, fig 3-4). The front of the lens rests against the aqueous humor, the rear against the vitreous humor. The *suspensory ligaments* and muscles

of the ciliary body draw upon or release the outer edges of the lens to change its refracting power by altering its shape.

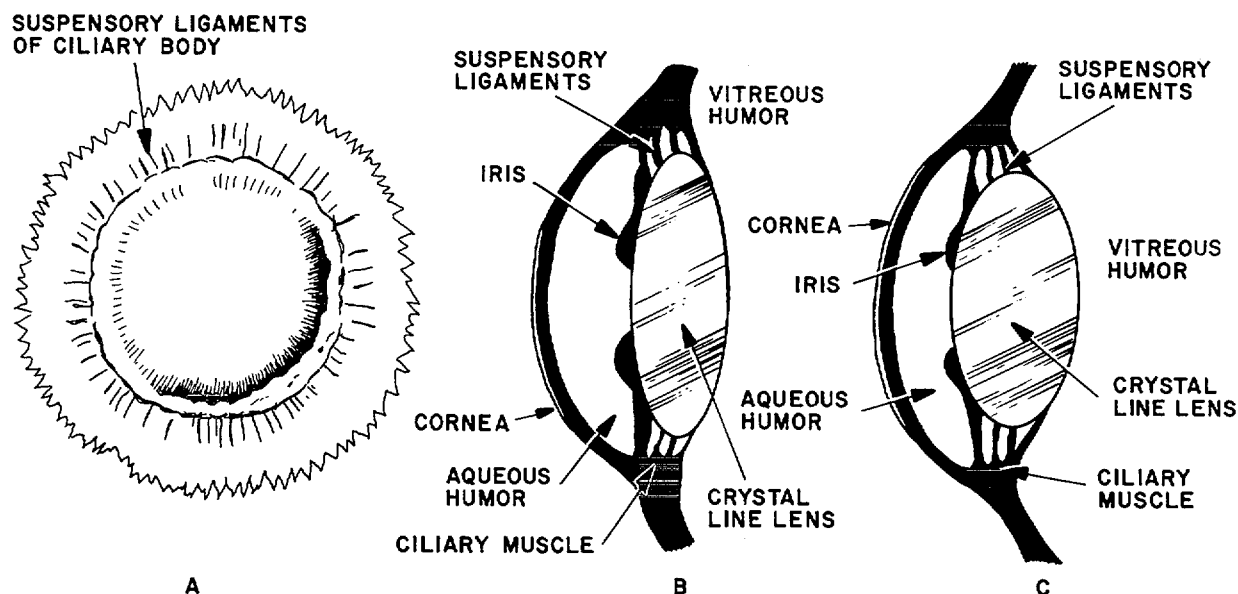

AR910082

Figure 3-4. Suspension and action of crystalline lens .

d. The crystalline lens is double-convex and the front surface is flatter than the rear (fig 3-2). When the eye is relaxed (B, fig 3-4) the lens of a normal eye will focus upon distant objects. To increase the refractive power of the lens, for focusing the eye upon a close object, the surfaces are made more strongly curved, more convex by the compressive action of the tense muscles of the ciliary body (C, fig 3-4). This process is known as *accommodation*, permitting the normal adult eye to view near objects as close as 25 centimeters (about 10 inches). An object viewed at this distance is said to be at the *near point* of the eye. The ability to accommodate usually decreases as a person gets older making the wearing of bifocals

necessary in most cases. Bifocals contain lenses having a small section ground to a higher power through which the user looks at near objects.

e. The image formed on the retina is inverted, but we do not see the image inverted, as there is simply a correspondence between the retina and external directions.

### 3-6. Response Mechanism.

a. The response mechanism of the eye, the area on which images are formed and examined consists of the retina (fig 3-5) or thin inner coat of the eyeball which is sensitive to light. The cause of light sensitiveness of this area is an almost infinite number of visual cells. They are connected by nerve fibers to the optic nerve

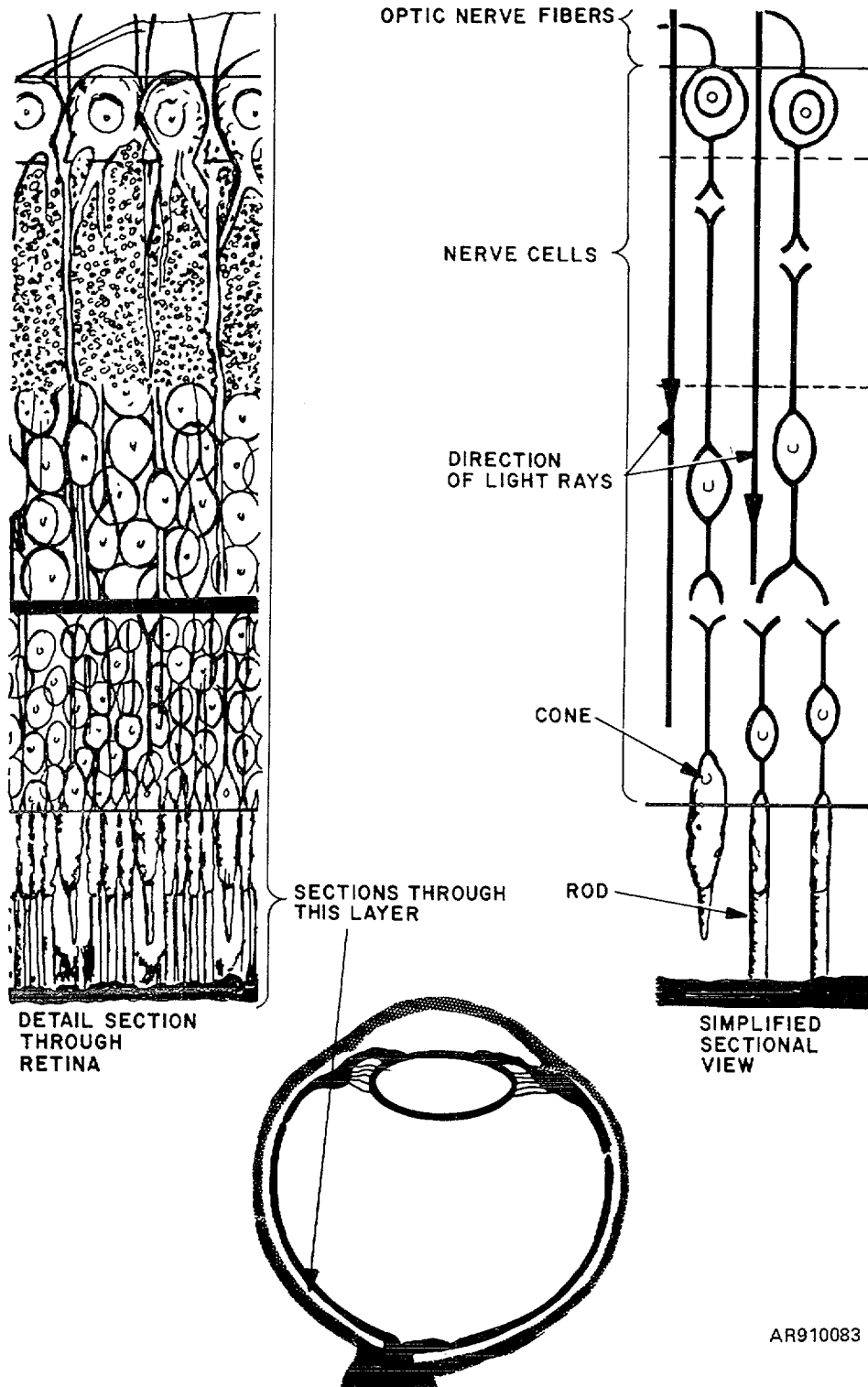

AR910083

Figure 3-5. Cones and rods of retina .



b. The light sensitive elements or visual cells are of two distinct types called rods and cones (fig 3-5). The rods are cylindrical-shaped and longer than the cones; the shorter cones are bulb-shaped. All are so small that they must be magnified to 300 times their actual size to be visible. While the mechanism of the eye has not been fully explained it appears that the cones provide daylight vision, where light intensities are high; the rods are more sensitive to light, and give twilight vision, where light intensities are low. The cones give clear sharp vision for seeing small details and the distinguishing of colors; the rods detect motion.

c. A slight depression in the retina on the visual axis of the eye is called the *macula* or *yellow spot*. It is about 2 millimeters in diameter and contains principally cones and only a few rods. At the center of the macula is the fovea or fovea centralis, where the retina is much more highly developed than elsewhere, a small area about 0.25 millimeter in diameter containing cones alone. This area of the retina, therefore, gives the sharpest detail and the best appreciation of color. No fibers of the optic nerve overlie it.

d. The rods are stimulated by a substance known as *visual purple* to increase their sensitiveness of subdued illumination. This substance builds up and accumulates during the time an eye is becoming accustomed to darkness. An eye affected in this manner is termed a dark-adapted eye. The visual purple is bleached out by light. A different substance serves the cones in the same way to produce what is known as a *light-adapted eye*.

e. One small portion of the retina is insensitive to all light. This is an area known as the blind spot or optic *disk*. It is where the optic nerve enters the eye and is located slightly to one side of the macula. In most instances, this blind spot has no effect on vision because the mind has learned to ignore it.

f. The optic nerve carries visual sensations to the brain. This nerve is really a cable of nerves through which the rods and cones activated by light images send messages to the brain which result in what is termed sight.

g. Foveal vision is much more acute than extrafoveal vision and the muscles controlling the eye always involuntarily rotate the eyeball until the image of the object toward which the attention is directed falls on the fovea.

h. The outer portions of the retina serve to give a general view of the scene and to warn of an object approaching within the field, while the fovea enables the object of chief interest to be examined minutely. If the eye is directed at a particular point on a printed page only the words close to that point are seen distinctly.

i. An impression registered upon the retina and the optic nerve persists, at least as a mental effect, for an appreciable time (about 1/15 sec) after the stimulus has been removed. Thus, the glowing end of a whirling stick gives the impression of a streak of light. This is known as *persistence of vision*. It is this effect which is the chief aid in securing the illusion of smooth motion in moving pictures so that we are not aware of the gaps between successive pictures.

### Section III. BINOCULAR (TWO-EYED) VISION STEREOVISION

#### 3-7. General.

a. Binocular vision is coordinated two-eyed vision. The two eyes of a person are normally identical and they work together as a team. The muscles used in adaptation and accommodation of the eyes are sympathetic in action; that is, they tend to dilate, contract, and focus together. Both eyes usually meet with the same light conditions and are turned to converge on the same object or field of view. The two images received by the eyes are not seen separately but are fused by the brain into a single image.

b. Stereoscopic vision, stereovision, or stereopsis, as it is called, is inseparably associated with binocular vision because it is the result of seeing with both eyes. Stereovision is the power of depth perception; the ability to see in three dimensions. This power is due to the spacing

between the pupils of the eyes which enables the eyes to see objects from slightly different angles. Eyes normally are about 62 millimeters apart. This distance between the eyes is called the *interpupillary distance* and is abbreviated "ipd".

c. The ability to record with each eye a slightly different picture or image of the same object often enables the observer to see more of one side of a given object with one eye than with the other. Together, the two eyes see farther around the object than one eye can see. They get a better impression of the shape of the object, its depth, and its position with relation to other objects. This ability is increased through the use of certain firecontrol instruments which increase the virtual distance between the pupils of the eye of the observer by optical means.

### 3-8. Field of View.

a. What may be seen by the eyes rotated in their sockets without movement of the head is termed the field of view; what may be seen without movement of the eye is termed the *field of fixation*. The field of view of the eyes is a horizontal extent of about 160° and a vertical extent of about 70°. In comparison, the average telescope has a field of view of about 10°.

b. The field of distant vision of immobile eyes is extremely limited, distinct vision being limited to only a very small central portion of the retina. Portions of the field focused on the remainder of the retina are seen indistinctly and serve as a finder to locate objects of interest. When an object

of interest is located, the eye turns in its socket until the image falls upon the central portion, the fovea and macula, and distinct vision is secured.

c. The field of vision of both eyes includes portions which are viewed by the right eye, the left eye, and both eyes (fig 3-6). The binocular field exists only in that portion of the field of view where the field of the separate eyes overlap. This explains why stereovision or depth perception is appreciated only in the center of the field of view, it is not apparent, except by association, in the outward portions of the field. The extreme outer areas of the field of view serve in the perception of motion, light, and shadow and form in two dimensions.

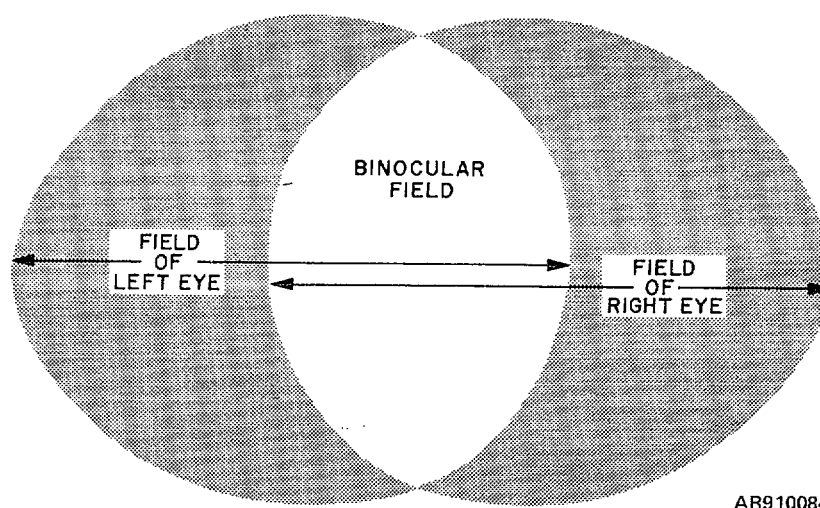

AR910084

Figure 3-6. Field of view of the eyes .

### 3-9. Principles of Stereovision.

a. In a military sense, stereovision implies the ability to recognize the existence of differences in range to objects by visual means only. It is an ability that can be developed by training and practice. Certain fire control instruments are designed to greatly increase the normal stereovision possessed by the individual.

b. There are various means requiring the use of but one eye which can be used to determine which of two objects is the more distant.

(1) When one object is known to be larger than another and both appear to be the same size, the larger object is known to be more distant.

(2) If an object partly conceals another, the second is recognized as being the farther away.

(3) Differences in the amount of atmosphere

(haze), light, and shadow; the difference in focus (accommodation of the eye) required for more than one object in the field of view; and the relative apparent movement of distant objects as compared with that of near ones when the head is moved from left to right, all influence the estimate of distance.

c. None of these means of depth perception are of value if its contributing factors are lacking. This is difficult to realize completely in any practical case, however, because one or more of these factors are present in almost all commonplace observations and are subconsciously used by persons with two-eyed vision whenever possible to augment their stereovision. Binocular vision can be investigated by placing two very small objects on a large table and then scanning them with the eyes

placed at the edge of the table. To gauge their relative distances, the use of both eyes and the employment of stereovision will be required.

*d.* A simple demonstration of stereoscopic vision can be made by looking at a near object such as a small cube. The observer will see a different view with each eye. The left eye will see the front and left side of the cube (A, fig 3-7). The

right eye will see the front and right side (B3, fig 3-7). The brain fuses these two separate pictures into a single image giving the impression of depth. The observer sees the front, both sides, and forms a conception of the depth of the cube, and in this way pictures the cube in three dimensions (C, fig 3-7).

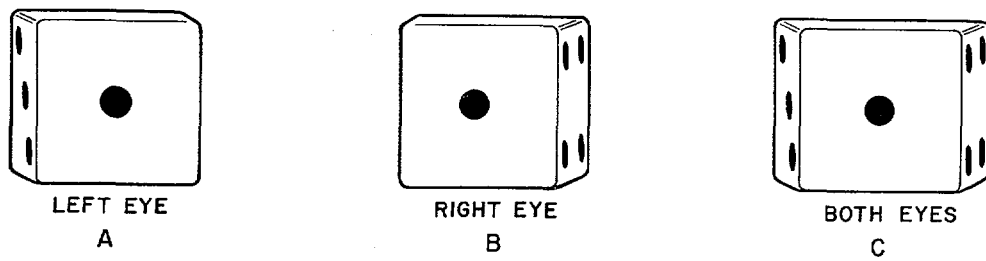

AR910085

*Figure 3-7. Cube is seen by left eye, right eye, and both eyes.*

e. In much the same manner when two objects are observed simultaneously, stereovision enables the observer to judge the relative distance of one object from the other, in the direction away from the observer, or depth. This can be done with considerable accuracy without utilizing other characteristics which suggest nearness of distance.

f. The ability to distinguish the relative positions of two objects stereoscopically depends upon the interpupillary distance of the observer's eyes, the

distance of the objects from the observer, and their distance from each other (A, fig 3-8). Other factors of depth perception being equal, the wider the spacing between the pupils of the eyes, the better appreciation of depth, one should be able to secure by stereovision. The farther one object is from the observer, the farther away the second object must be from the first, if the observer is to distinguish their relative positions stereoscopically

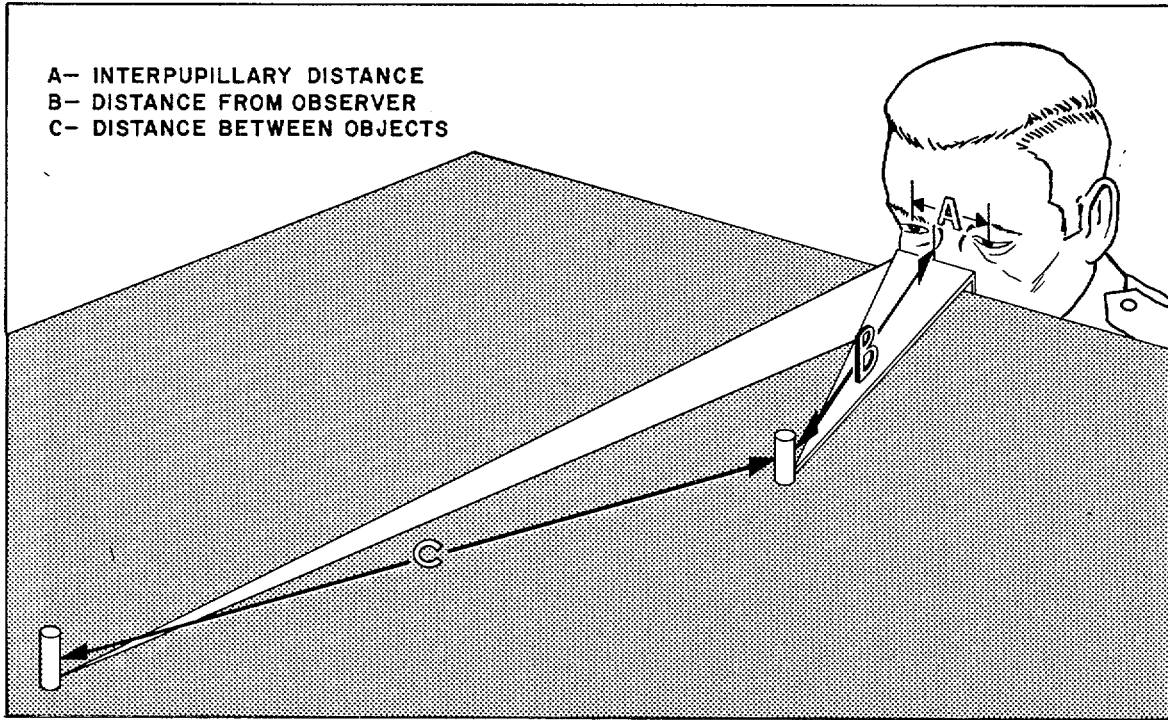

A-THREE FACTORS LIMIT JUDGING OF RELATIVE DISTANCE

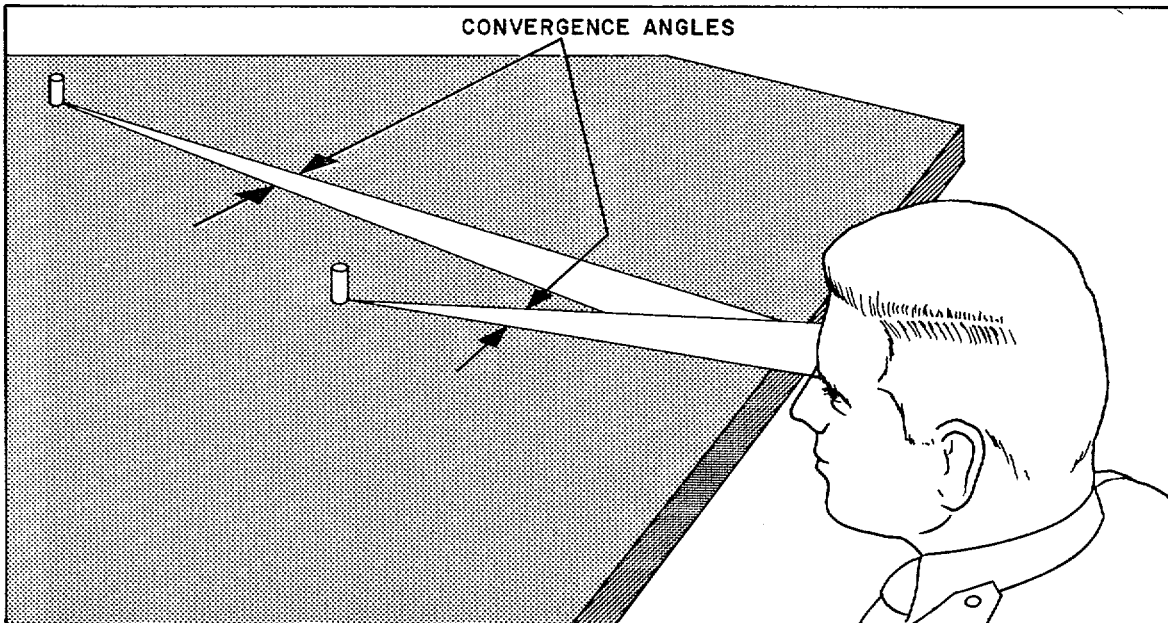

B-LINES OF SIGHT FORM CONVERGENCE ANGLES

AR910086

Figure 3-8. Judging distance .

**TM 9-258**

g. When a person looks at two objects and attempts to determine which is farther away, the lines of sight from both his eyes converge or come together to form angles on both of these objects. The angles formed by the converging lines of sight are the angles of convergence (B, fig 3-8). If the angles of convergence to both objects appear to be identical, there is no impression of one being farther away than the other. If there is a difference

in the angles of convergence to the two objects, one of the objects will appear more distant.

h. The difference between angles of convergence may be slight but the brain possesses the faculty of distinguishing between them. The ability to see stereoscopically is dependent upon the ability to discern the difference between angles of convergence (A, fig 3-9).

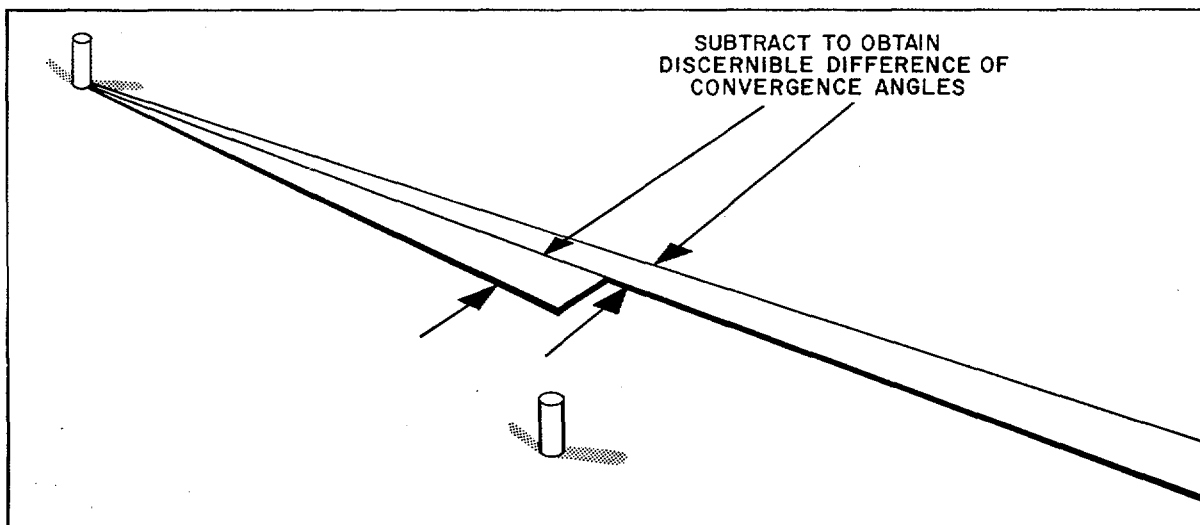

A—GRAPHIC VIEW OF DIFFERENCE BETWEEN CONVERGENCE ANGLES SHOWN IN A AND B FIGURE 3-8

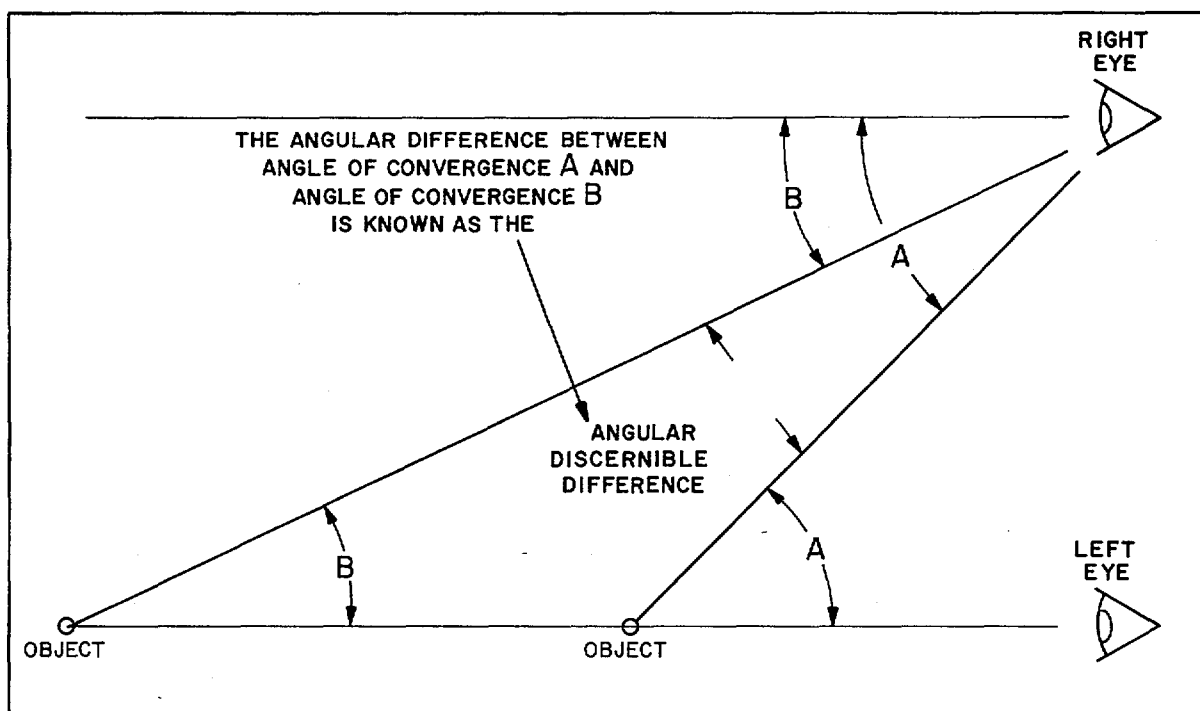

B—CONVERGENCE ANGLES IN STEREOSCOPIC VISION

AR910087

Figure 3-9. Angular discernible difference.

i. Angles of convergence become smaller and the difference between them becomes more difficult to discern as the objects are farther removed from an observer or as their distance from one another is decreased. This difference is known as the discernible difference of convergence angles (B, fig 3-9) and is measured in fractions of minutes and seconds of arc. This provides a means of gaging the ability of observers to see stereoscopically.

j. The sense of depth perception or stereoscopic vision for the unaided eye is effective, at most to 500 yards. In using a binocular or range finder, the lines of sight for the two eyes are further separated thus increasing stereoscopic vision.

k. *Stereoacuity* (or stereopsis) is sharpness of sight in three dimensions. It is the ability to gage distance by perception of the smallest discernible difference of convergence angles. This ability may

be developed by practice and training which aids recognition. The smallest difference between convergence angles that an observer is able to distinguish is known as his *minimum discernible difference of convergence angles*.

l. The minimum difference that can be discerned between two angles of convergence depends upon the vision of the individual observer, his state of training, and other general conditions such as visibility. A well-trained observer should consistently discern an average difference of 12 seconds of arc and at times, under excellent observing conditions, this difference may be reduced to as low as 4 seconds of arc for a series of observations.

The average untrained observer should be able to distinguish a minimum difference of 30 seconds of arc between two angles of convergence under normal conditions of visibility.

**Section IV. DEFECTS AND LIMITATIONS OF VISION**

**3-10. General Eye Defects.**

a. *Classification of Eye Defects.* Common eye defects fall into two classifications: those pertaining to sight itself and those which are the result of muscular disorder. Names ending in "ic" signify the condition while "ia" signifies the name of the disorder. Likewise, the "tropias" derived from the Greek "op" meaning sight, signify optical or sight abnormalities while the "phorias," from the Greek "phora" meaning movement, signify muscular disorders. The normal eye is said to be emmetropic; the person enjoys emmetropia. The abnormal eye is ametropic; the person suffers from ametropia.

b. *Common Eye Defects.* The common eye defects are listed below. Explanation may be found in the glossary.

Nearsightedness (myopia)      Farsightedness  
(hypermetropia)                      or                      hyperopia)

- Old-sightedness (presbyopia)
- Astigmatism
- Colorblindness (dichromatism)
- Night blindness
- Muscular imbalance (heterophoria)
- Double vision (diplopia)
- Squint, cross-eye, wall eye (strabismus)

c. *Nearsightedness and Farsightedness.* The size of the eyeball, the curvature of the cornea, and the focal length of the compound elements are not always matched. If the lens is too convex or the retina too far back, the eye is nearsighted or myopic. This condition is corrected by negative or diverging spectacles (fig 3-10). If the lens focal length is too long or the retina too close, the eye is farsighted or hypermetropic. This condition is corrected by positive or converging spectacles (fig 3-11).

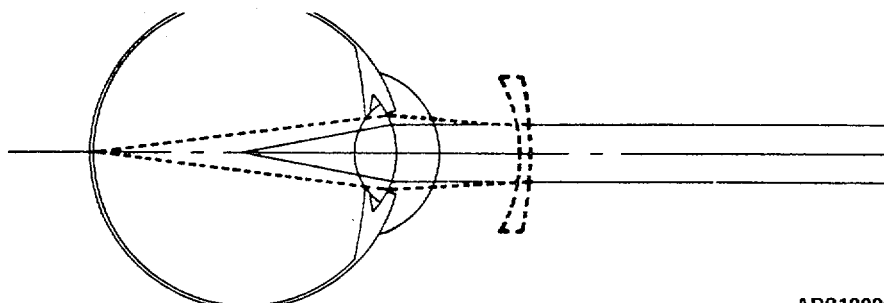
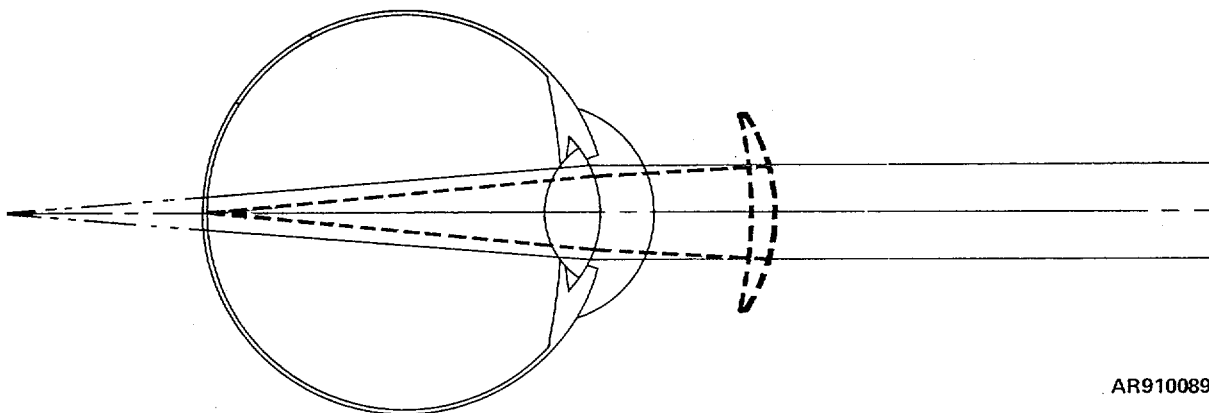

Figure 3-10. Nearsightedness (myopia)

AR910088





AR910089

Figure 3-11. Farsightedness (hypermetropia)

d. *Astigmatism of the Eyes.* This condition occurs when at least one refracting surface is not spherical but is somewhat cylindrical (curvature not symmetrical). In this case the image of a point source is not a joint image but a short line image as in A, figure B-5. Such line images will form from sources on the optical axis. Thus, visual astigmatism is different from that encountered in optical instruments (where astigmatism of a properly centered spherical lens system is zero on the axis). This condition is corrected by cylindrical or toroidal (toric) spectacles.

**3-11. Visual Limitations.**

a. *Apparent Size (A, fig 3-12).* This is the basis of all magnification (para 2-4 e (1)). It is measured by the angle the object subtends at the point of

observation. This is not to be confused with actual size. A plane flying away from one will shrink in apparent size until it is only a speck in the sky. Obviously, it does not become any smaller but, as it recedes, light rays from the wingtips make a progressively smaller angle until the eye no longer can separate them and the entire plane appears as a single point. Apparent size then is inversely proportional to distance and is expressed mathematically as follows:

$$\text{Apparent Size} = \frac{\text{Size of Object}}{\text{Distance to Object}}$$

When two adjacent objects become so small in apparent size that any further reduction in size results in failure of the eye to separate them, the angle of resolution of the eye has been reached.

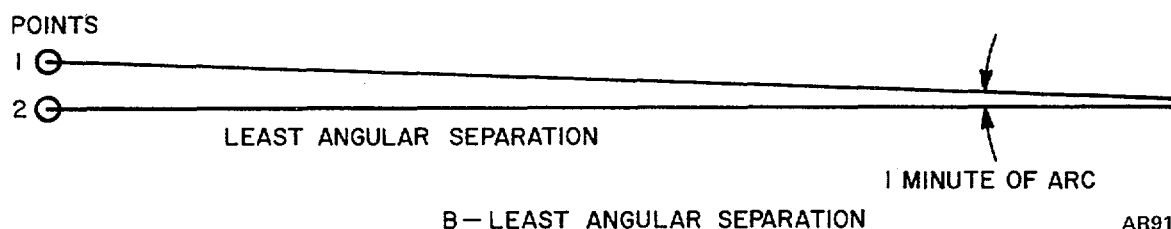
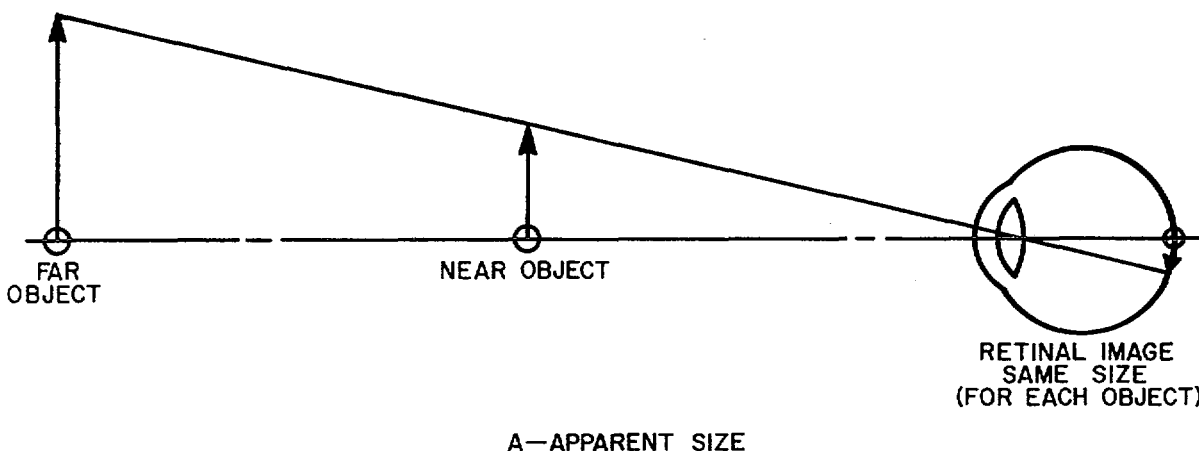

AR910090

Figure 3-12. Visual Limitations

b. *Resolving Power of the Eye.* The retina is a mass of nerve endings. Their individual diameters (between 0.0015 millimeter and 0.0054 millimeter) determines the resolving power of the particular eye. The size of these nerve endings vary in different individuals. These nerve endings may be compared to the sensitive particles in a photographic film. Although a perfect image may be formed in the retina, it will not be perceived as such, for the distance between two adjacent image points must be greater than the distance between rods or cones (nerve ends) for perception.

c. *Acute Vision.* Acute vision is limited to the area of the *fovea centralis*, a spot (about 0.25 millimeter in diameter) on the macula which lies on the retina at the visual axis. Here are cone nerve endings alone instead of the longer rods with a diameter of approximately 0.002 millimeter. This area of acute vision covers a true field of less than 1° of arc (ordinarily) or a circle approximately 3.5 millimeters in diameter at 25 centimeters distance from the eye. Least angular separation between any two discernible points in this field of acute vision is normally one minute of arc (B, fig 3-12). Coincident readings, as on a vernier or micrometer, can be read closer as angular displacement of two

lines can be distinguished by adjacent cone endings closer than displacement of points. Some persons can read accurately angular measurement (between two displaced lines) as small as 10 seconds of arc.

d. *Measure of Visual Acuity.* Visual acuity is keenness of sight. It is the ability to see near and distant objects clearly in order to compare minute details and to discriminate between them. Visual acuity commonly is measured by viewing a standard letter of one-minute details, such as the following example: A person able to view the letter E composed of lines one minute of angle of width at the standard distance of 20 feet is said to possess 20/20 vision. In case a letter is used at 20 feet which should normally be identified at 40 feet, vision is said to be 20/40. Some eyes, on the other hand, have better than average resolving power and can perceive letters having less than one-minute details. An example of this is 20/10 vision, which is the ability to discern at 20 feet what the normal eye can appreciate at 10 feet. A whole series of letters have been designed (subtending one-minute details at their respective distances) for use at the standard distance, so that the testing can be done at a fixed distance rather than at various distances.

## Section V. OPTICAL INSTRUMENTS AND THE EYES

**3-12. General.** Optical fire-control instruments may be placed in two general classifications: monocular, for the use of one eye and binocular, for the use of both eyes. Both types require certain adjustments to accommodate them to the eye as the use of any optical instruments affects the functioning of the eye itself.

### 3-13. Accommodation of Optical Instruments to the Eyes.

*a. Conditions for Clear Vision.* In order that the eye may function properly in the use of a monocular instrument, the instrument must be focused to permit light entering the instrument from an object to form a distinct image on the retina without undue effort on the part of the eyecontrolling muscles of the observer. The exit pupil (rear opening of the eyepiece) must be sufficiently large to let the maximum amount of light enter the pupil of the eye. Stray light must be kept out of the eye. In addition, the use of a binocular instrument demands that the two optical systems of the unit be properly aligned with each other and conform to the interpupillary distance of the individual.

*b. Focusing.* Precise focusing of the instrument permits light from the object to form a distinct image on the retina. Focusing changes the position of the eyepiece with relation to the focal plane of the objective and the angles at which the light rays are brought to a focus. The eyepieces of focusing-type telescopes generally are designed to accommodate the refracting qualities of the eyes of individual observers. If the instrument is used consistently by an individual, the eyepiece setting can be memorized to expedite the focusing of the instrument. Low-power telescopes have a wider range of accommodation without adjustments than high-power telescopes. Telescopes in which the magnifying power is 4X or less have a sufficiently wide range of accommodation so that a single focus setting will be satisfactory inasmuch as the eye correction is not extremely large. They are generally constructed with a fixed-focus eyepiece which cannot be adjusted during operation. They are called fixed-focus telescopes, and usually have a minus 3/4 to minus 1 diopter setting (para 10-2).

*c. Use of Spectacles.* If the proper spectacles are worn, the corrected eyes will focus at the normal setting of the instrument. However, the use of spectacles prevents the eyes from coming up properly to the eyeshield of the instrument and the eye may be placed so far from the eyepiece as to restrict the field of view. In spite of these con-

siderations, when the eyes are seriously affected by astigmatism, the observer should not remove his spectacles as no compensating adjusting can be secured by focusing the eyepiece of the instrument.

*d. Eyeshields.* The proper fit and use of the eyeshields should be such that it excludes stray light from the eyes. This is particularly important in night observation and under conditions of poor illumination so that the pupil may dilate as much as possible. If a monocular instrument is used, the eye not in use should also be shielded from light; if it receives too much light, the pupil of the eye in use will contract sympathetically. Rubber shields at the eyepiece make the most effective seal. Any light used to illuminate the reticle must be held to a bare minimum.

*e. Interpupillary Adjustment.* A binocular instrument must be adjusted to the eye spacing or interpupillary distance of the observer. If this is not done, the lines of sight of both eyes cannot traverse the most effective optical paths of the instrument; the observer will not have full binocular vision, nor view the most distinct images, nor be able to seal out unwanted light from the eyepieces. Practically all instruments of this type are equipped with means for interpupillary adjustment. They are marked with calibrations for such adjustment. The observer should determine his interpupillary distance (para 2-35), memorize it, and adjust any such instrument he may use to conform to the spacing between the pupils of his own eyes.

### 3-14. Eye Tension or Fatigue

*a.* Blinking of the eyes is an automatic process resulting from eye tension or fatigue. It will occur in the use of optical instruments because the eyes cannot focus steadily very long without relaxing. It is muscular rather than retinal, and is least apparent when the eye is relaxed as when accommodated for distant objects. For this reason, in focusing an instrument, it should be focused for distance and the first distinct focus setting should be used.

*b.* Fatigue of the eye muscles will be experienced after comparatively short periods of continuous observation. This fatigue usually is greater with low illumination. Inasmuch as the eyes quickly recuperate, frequent rest periods are advisable.

*c.* A particular type of fatigue results from the use of binocular instruments if not set at proper interpupillary distance. This is due to the fact that both eyes involuntarily adjust themselves so that a

single image is formed when the image is focused on the macula of each eye where best vision is obtained. Under ordinary conditions this is done when viewing a distant object. In using an instrument, images may be at different points and

the eyes are placed in a condition of forced equilibrium by the expenditure of an amount of nervous and muscular force resulting in rapid fatigue.

## CHAPTER 4

## OPTICAL COMPONENTS, COATED OPTICS, AND

## CONSTRUCTION FEATURES

## Section I. OPTICAL COMPONENTS

**4-1. Optical Glass.**

*a. Types.* Two of the most important types of optical glass are known as crown glass and flint glass. Crown is an alkali-lime glass. Boro-silicate crown glass contains salts derived from boric and silicic acids. Flint glass contains lead. The refractive indices of these types of glass are listed in paragraphs 2-12c and 5-31a.

*b. Characteristics.* The characteristics affecting the values of all types of optical glass may be divided into the purely optical properties, which directly influence the light in passing through the glass, and the general physical qualities. The purely optical properties are constant density (homogeneity), transparency, refraction, dispersion, and freedom from color and defects. The general features of optical glass are chemical stability, mechanical hardness, and freedom from internal strain.

(1) Constant density or homogeneity is the most important property. The uniformity of the index of refraction of a given sample of glass is dependent upon its constant density.

(2) The greater the transparency, the less light is absorbed and the more light will pass through.

(3) The refractive and dispersive qualities are dependent upon the type of glass. Crown glass has approximately half of the dispersive power (ability to spread the colors of so-called white light) of flint glass.

(4) Freedom from color tint, while preferable, is not as essential as the other requirements. It is obtained by careful selection of raw materials which must be of the greatest possible purity.

(5) Types of defects are known as stones, bubbles, seeds, and striae (layers). Stones are due to solid material that accidentally may get into the molten glass at the time of manufacture. Bubbles are air pockets in the glass. Seeds are very minute bubbles. Striae are wavy bands which appear to be of different density and color than the surrounding medium.

(6) Chemical stability and mechanical hardness determine the resistance of the finished optical element to handling and contact with atmospheric moisture.

(7) Freedom from internal strain depends upon annealing or very slow cooling of the glass in manufacture. Any large amount of internal strain may cause the glass to break during grinding or if subjected to shock at any time after grinding.

*c. Manufacture.* Although an understanding of the manufacture of optical glass is not essential to a knowledge of elementary optics, some appreciation of the many processes involved will show why fine optical glass is considered a critical material. The finely divided materials are very thoroughly mixed, usually by hand. This mixture is melted in small charges, small quantities being fed to the melting pot at intervals regulated by the melting time of the charge previously introduced. Each charge is brought to a liquid state before the next charge is placed in the pot. The next operation, the fining process, consists of holding the molten glass mixture at a high temperature, sometimes as long as 30 hours, to drive off the bubbles contained in the liquid. To secure homogeneity and prevent striae, the molten glass is then stirred during the gradual cooling of the mass until it is so stiff that the stirrer cannot be moved. The mass is stirred from 4 to 20 hours, depending on the glass and the size of the pot. As soon as the stirring ceases, the pot is withdrawn from the furnace and allowed to cool to about the annealing temperature. It is then placed in an annealing kiln at a temperature of from 4000 to 5000 C. and slowly cooled to ordinary temperature. Annealing takes from 1 to 2 weeks, according to the size of the batch. When cooled, the pot is withdrawn from the annealing kiln and broken away from the glass.

**4-2. Lenses.**

*a. Single Lenses.* Lenses are optical elements with polished faces, one plane and one spherical or

both spherical. Lenses deceive the eyes by bending rays of light so that, depending on the type of lens, they appear to come from closer and larger objects or from farther and smaller objects. Lenses are divided into two general classes (fig 4-1). One

class forms real images and lenses in this class are termed convex, convergent, positive, or collective lenses. The other class can form by itself only virtual images and lenses in this class are termed concave, divergent, negative, or dispersive lenses.

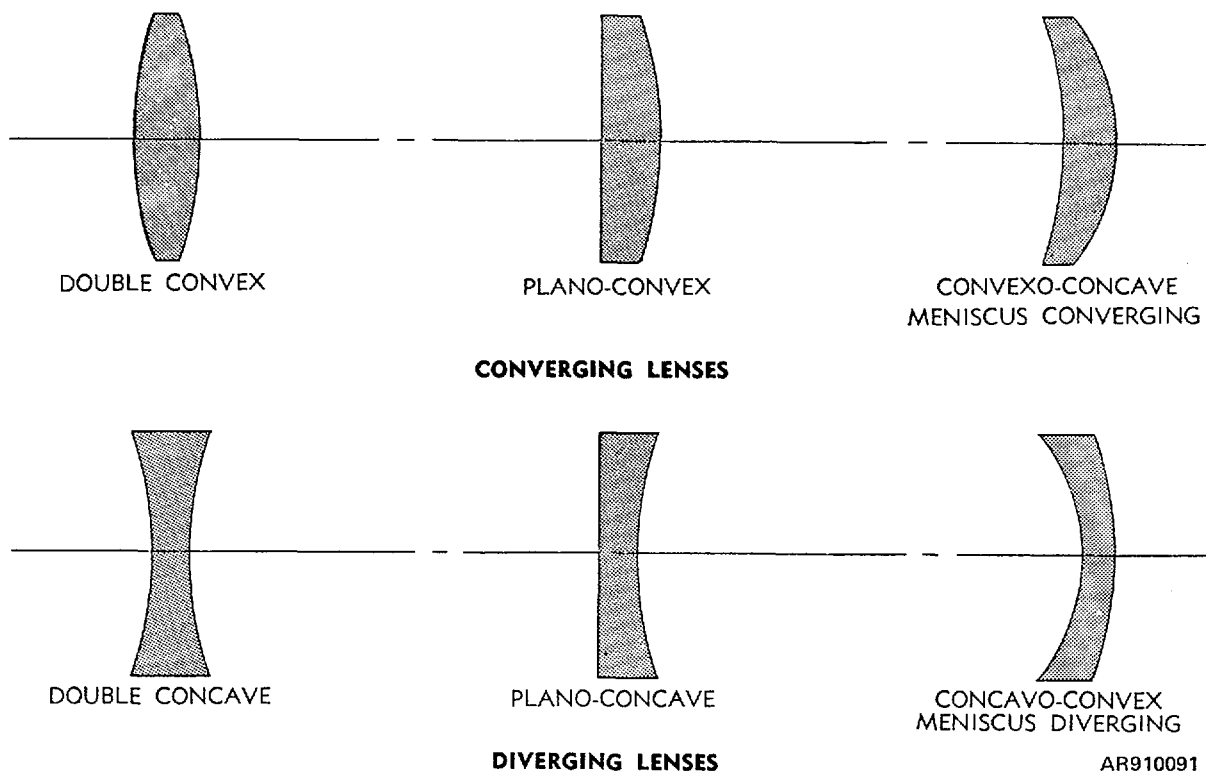

AR910091

Figure 4-1. Types of simple lenses.

(1) Convex lenses. All convex or converging, positive lenses are thicker in the center than at the edges and will converge light from sources and objects. Both faces of a convex lens may be convex, one surface may be convex while the other is flat (termed *plano* or plane), or one face may be convex while the other is concave.

(a) A double-convex lens (fig 4-1) is one in which both surfaces have convex curvature. Both surfaces contribute to the converging power of the lens. The greater the convexity of the surfaces, the shorter the focal distance.

(b) A planoconvex lens (fig 4-1) has a plane surface and a convex surface. The plane surface does not contribute to the converging power of the lens.

(c) The *convexo-concave* or, *meniscus converging lens* (fig 4-1) possesses both a convex and a concave surface with both centers of curvature on the same side of lens. The more powerful convex curve makes this a positive lens despite the fact that the concave surface tends to diverge the light, thus subtracting from the converging power of the lens. Meniscus lenses are mainly used for

spectacles because they permit undistorted vision through their margins 'as the eyes are rotated in their sockets.

(2) *Concave Lenses*. *Concave or diverging, negative lenses* (fig 4-1) are thinner in the center than at the edges and will diverge light from sources and objects. Both surfaces of a divergent lens may have a concave curvature (doubleconcave); one surface may be concave and the other plane (planoconcave); or one face may be concave while the other is convex (concavoconvex or divergent meniscus), with both centers of curvature on the same side of lens.

(3) *Cylindrical lenses*. Cylindrical lenses are ground with a cylindrical surface instead of a spherical one; they are either positive or converging, or else they are negative or diverging. Their use is very limited. They are used in some of the coincidence range finders.

b. *Compound Lenses*. As an optically perfect single lens cannot be produced, two, three, or more lenses ground from different types of optical glass are frequently combined as a unit to cancel

aberrations or defects which are present in the single lens (paras 2-37 thru 2-42).

(1) The refractive power of a compound lens is less than that of the convex lens alone. For example, if a double-convex lens of crown glass is combined with a planoconcave lens of flint glass, the latter would have little more than half the

refraction power of the former but sufficient dispersive power to neutralize the dispersion. The result would be that light passing through this compound lens would be brought to a practical focus at a point that would be about double the distance of the point of principal focus of the crown lens alone (fig 4-2).

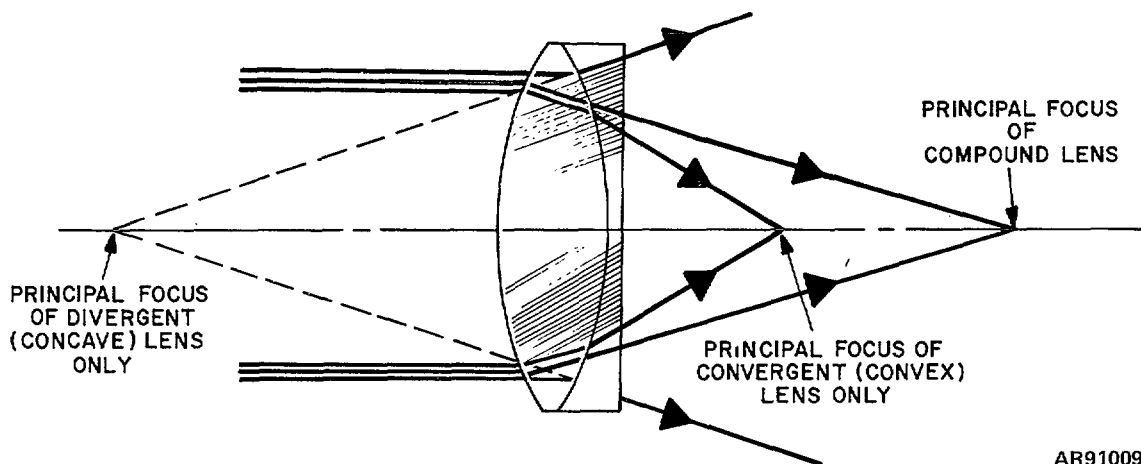

AR910092

Figure 4-2. Comparative focal lengths of elements in compound lens.

(2) The elements are frequently cemented together with their optical axes in alignment. Two lenses may be cemented together as a *doublet* or three may be cemented together as a *triplet*, or each lens of the unit may be mounted separately as a *dialyte* (fig 4-3). In the *dialyte* compound lens, the inner surfaces of the dissimilar faces of the two lenses cannot be cemented together inasmuch as they are ground to different curvatures in order to correct for aberrations; the two lenses are separated by a thin ring spacer and are secured in a threaded cell or a tube with burnished edges. The cementing of the contact surfaces, ground to the same curvature, generally is considered desirable because it helps to maintain the two elements in alignment under sharp blows, it aids cleanliness, and it decreases the loss of light through reflection

at the two surfaces in contact, if the cement used, such as thermosetting cement (para 2-12c), is a substance having approximately the same index of refraction as glass.

#### 4-3. Objectives.

*a. General.* The lens nearest the object in any optical system of the refracting type is called the objective. Its function is to gather as much light as possible from the object and form a real image of that object. Objectives lenses in most optical instruments form real images (except Galilean telescope).

*b. Construction.* The majority of objectives are constructed of two elements, a double-convex converging lens of crown glass and a planoconcave flint lens (A, fig 4-3).

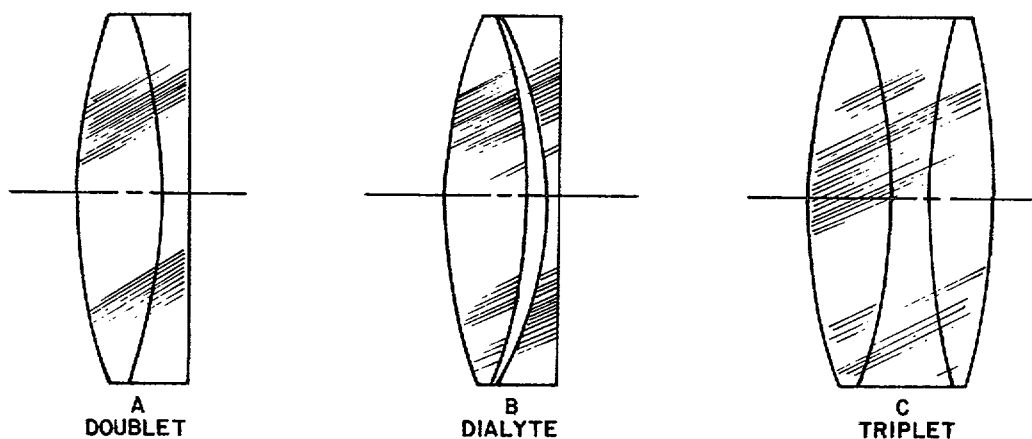

AR910093

Figure 4-3. Types of objectives.

(1) When the elements of the objective are of large diameter or when the faces of the elements are of different curvature, the elements are not cemented but are held in their correct relative positions in a cell by separators and a retaining ring (B, fig 4-3 and 4-35). This construction permits giving the inner surfaces of the two elements different values and allows greater freedom in the correction of aberrations. An objective of this type is often called a dialyte or Gauss objective.

(2) Certain objectives are composed of three elements securely cemented together (C, fig 4-3) or with two of the elements cemented and one mounted separately, or with all three elements mounted separately. Such objectives afford a total of six surfaces upon which the designer can secure the best possible correction for aberrations.

*c. Relation of Objective to Optical System.*

(1) The size of the objective affects the amount of magnification that can be used in the instrument. Only so much light can pass through a given objective. If the magnification were increased, that amount of light would be distributed over a larger image area and a dimmer image would result. The effective size to which an image

may be magnified is, therefore, governed to a great extent by the size of the objective. It is likewise governed by the limits set by distortion due to diffraction (para 2-43b).

(2) Increasing the size of the objective beyond a certain point does not improve the brightness of the image appreciably because of the restriction imposed by the size of the pupil of the eye.

(3) Some fire-control instruments, notably tank telescopes, have objectives which are smaller than the eyelenses of the instruments. Most instruments of this nature, however, have low magnification. Others sacrifice a certain amount of the light-gathering qualities of the larger objective for compactness of instrument.

#### 4-4. Eyepieces.

*a. General.* The *eyepiece* may be considered a magnifying glass which enlarges the image produced by the objective (fig 4-4). The eyepieces of modern fire-control instruments generally consist of two or three lenses; one, two, or all three of which may be compound lenses.



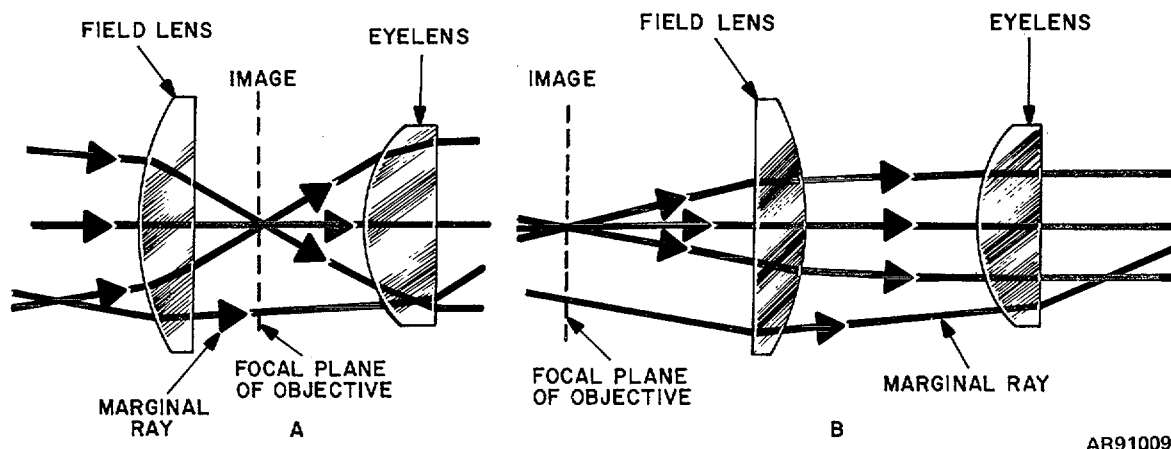

AR910094

Figure 4-4. Typical light paths through field lens and eyelens of eyepieces.

b. *Construction.* The lens of the eyepiece nearest the eye is called the eyelens. The eyelens does the actual magnifying of the image and can affect the quality of the image as seen by the eye. The lens in the eyepiece nearest the objective is called the field lens. The field lens gathers the light from the objective and converges it into the eyelens. If it were not for the field lens, much of the marginal light gathered by the objective would not be brought into the field of the eyelens (A and B, fig 4-4).

c. *Relation of Eyepiece to Optical System.* The objective takes nearly parallel rays of light from a distant object and brings them to a focus turning them into angular rays. The eyepiece takes these rays, which are diverging after having been brought to a focus, and directs them into the eye.

d. *Magnification.* Magnification by the eyelens or eyelenses may be fixed of variable, or there may be no magnification. Some instruments are provided with changeable eyepieces to secure different degrees of magnification. In other instruments, the relative positions of lenses not in the eyepiece are changed to effect changes in magnification.

e. *Types of Oculars or Eyepieces.* Types of eyepieces used in optical fire-control instruments are discussed in the following subparagraphs. They represent general types rather than the specific eyepieces of instruments inasmuch as a specific type of eyepiece generally is modified to make it best suited for a particular instrument.

f. *Kellner.* The Kellner eyepiece (achromatized Ramsden, g below) consists of two lenses, field lens and eyelens; the eyelens is corrected for color and is a doublet or compound lens with the crown forward and the flat flint facing the eye. For full chromatic correction, image lies in plane surface of field lens, but to use with reticle is positioned forward of field lens as illustrated in A, figure 4-5. In this case, some color correction is sacrificed. To reduce aberration a dense barium crown and light flint are used in the eyelens. This ocular gives an achromatic and orthoscopic field that in some models is as large as 500. Its most serious disadvantage is the pronounced ghost resulting from light reflected successively from the inner and outer surfaces of the field lens. This system is common in prism binoculars.

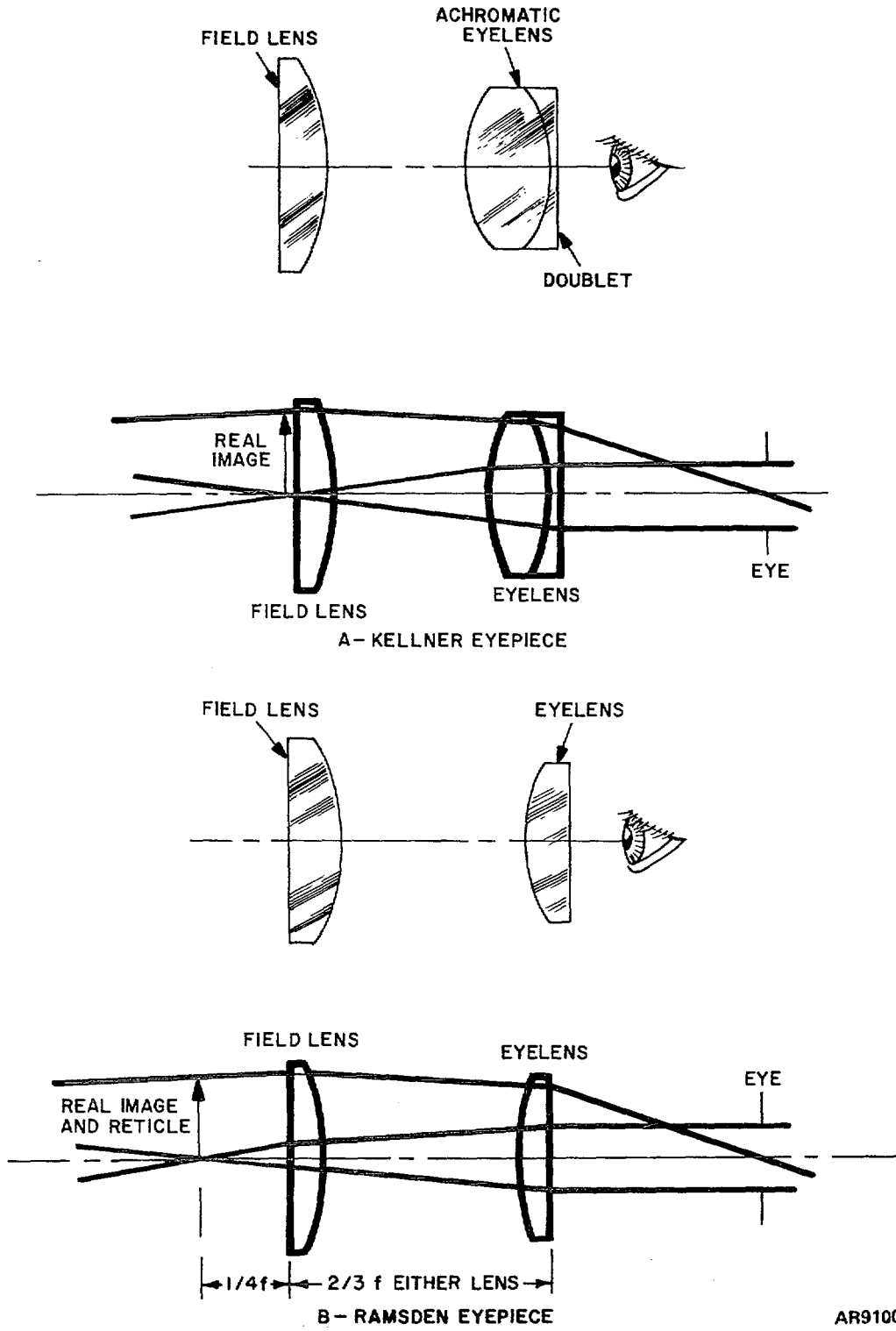

AR910095

Figure 4-5. Kellner and Ramsden eyepieces.

*g. Ramsden.* The Ramsden eyepiece consists of two planoconvex lenses made of ordinary crown glass of equal focal lengths separated by a distance equal to two-thirds of the numerical value of the focal length of either. The reticle is located in front of the field lens at one-quarter of its focal length as illustrated in B, figure 4-5. The field lens thus contributes to the magnification and quality of the image. Dirt on its principal plane is not in focus and, therefore, not visible. The convex surface of each lens faces the other. This eyepiece has the disadvantage of considerable lateral color which can be defined as a difference in image size for each color. It is widely used with reticles, however. This type of ocular can be used as a magnifier and it is therefore called a positive ocular.

*h. Huygenian.* This eyepiece employs a collective or field lens moved away from the eyelens so that the real image lies between the two lenses. The Huygenian eyepiece (A, fig 4-6) is not suitable for use with reticles in telescopes as distortion of the reticle would result since the individual components are not corrected for aberration. It is sometimes used however with a small reticle in the center of the field in some microscopes and it is useful in observation instruments. Eyepiece focal length usually used is over 1 inch for sufficient eye relief. Both elements are normally of the same type of crown glass with convex surfaces facing forward. This type of ocular is of negative type in contradistinction to the Ramsden or positive type (g above).

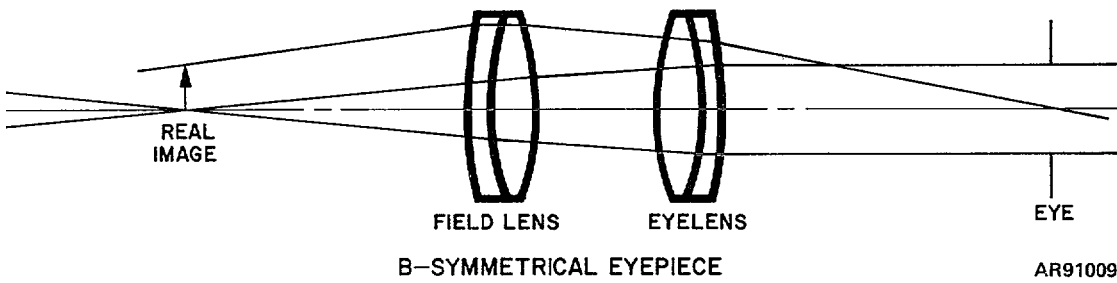
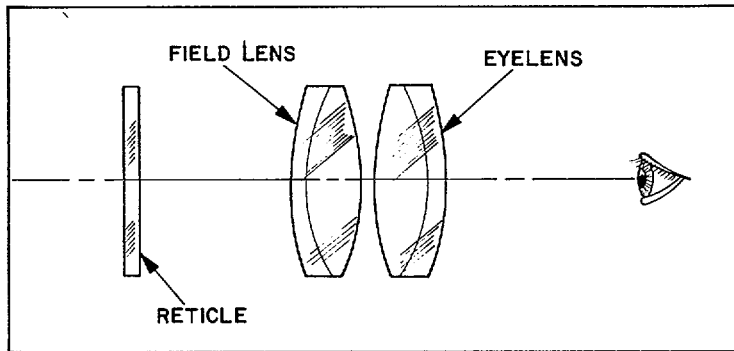
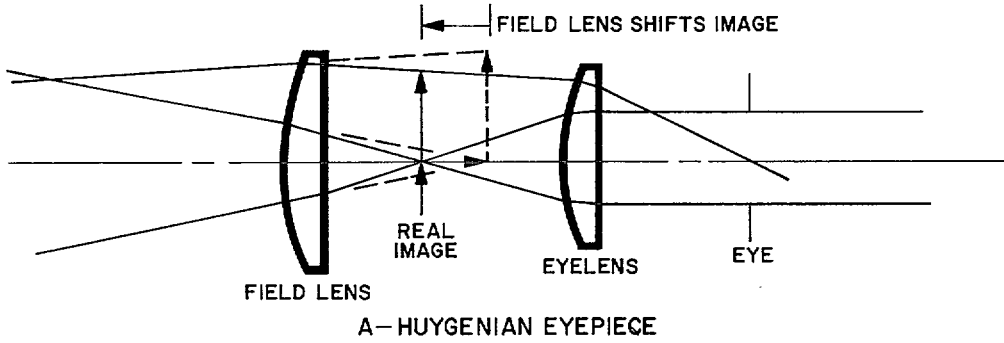
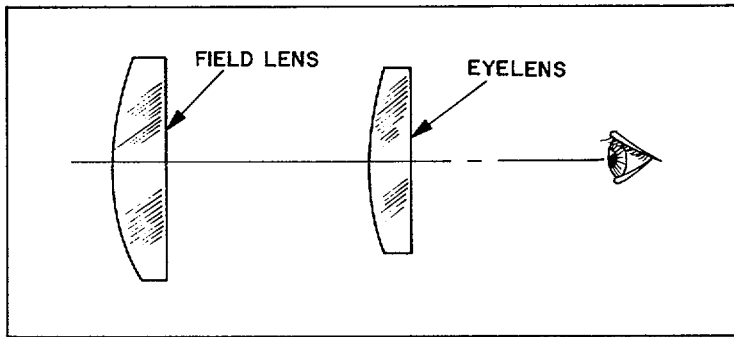

AR910096

Figure 4-6. Huygenian and symmetrical eyepieces

*i. Symmetrical.* This eyepiece employs two doublet (compound) double convex lenses, with the greater curvature (crown side) of each lens facing that of the other. The symmetrical eyepiece illustrated in B, figure 4-5, provides long eye relief (related to low power and large exit pupil). It has a larger aperture than a Kellner of the same focal length providing a rather wide field. It is used commonly in rifle scopes and gunsights requiring long eye relief between the eye of the gunner and the eyepiece when the weapon recoils, and low power with a large field.

*j. Erfle.* The Erfle eyepiece illustrated in A, figure 4-7 employs three elements. One is a concavo-convex doublet field lens. Another is a symmetrical collective center lens which adds to the power of the eyepiece by shortening the focal length and improves the illumination of the outer

portion of the field providing a more uniformly illuminated image. The third is a double convex doublet eyelens with a slight curvature facing the eye and the greater curvature facing the collective lens and the convex surface of the field lens. The periscope using this eyepiece is the battery commander's periscope.

*k. Orthoscopic.* This eyepiece is illustrated in B, figure 4-7. It employs a planoconvex triplet field lens and a single planoconvex eyelens with the curved surface of the field lens facing the curved surface of the eyelens. It is free of distortion and is useful in high-power telescopes because it gives a wide field and high magnification with sufficient eye relief. It is useful in range finders to permit use of any part of the field. It is so named because of its freedom from distortion.

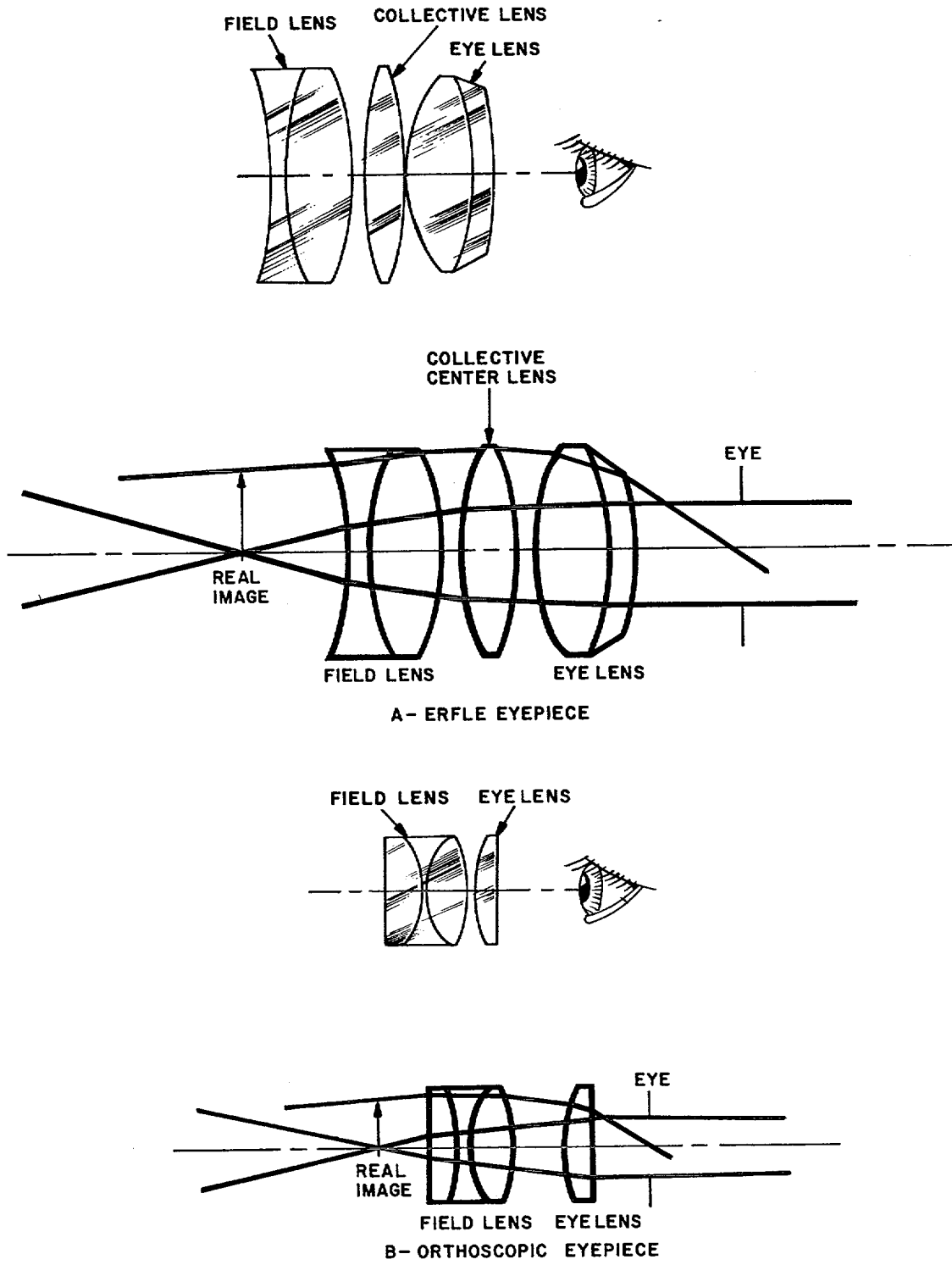

AR910097

Figure 4-7. Erfle and orthoscopic eyepieces.

l. *French*. This eyepiece is illustrated in A, figure 4-8. It employs elements substantially resembling those of the orthoscopic eyepiece in the reverse order. It was generally indicated on French drawings furnished the United States of America during World War I.

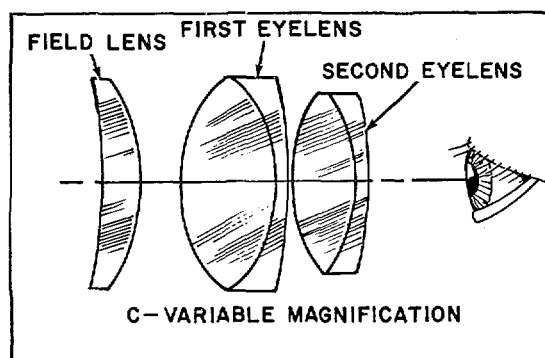
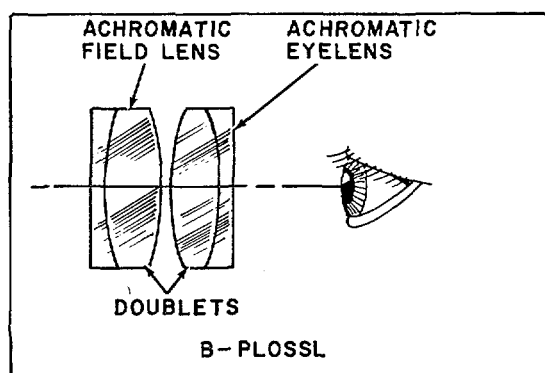
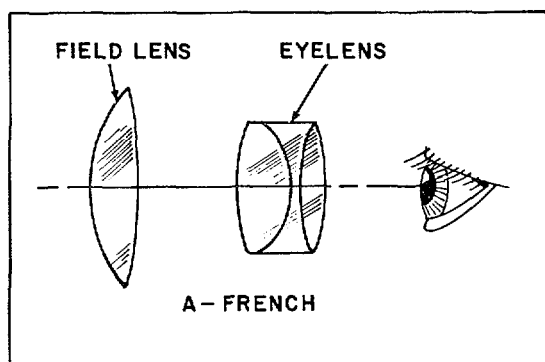

AR910098

Figure 4-8. French, Plossl, and variable magnification eyepieces.

m. *Plossl*. This eyepiece employing an achromatic doublet for each lens is illustrated in B, figure 4-8. The converging components of the doublets face each other.

n. *Eyepiece With Variable Magnification*. These eyepieces generally employ two eyelenses in addition to the field lens. The forward eyelens is called the first eyelens and the eyelens nearest the

eye, the second eyelens (C, fig 4-8). Variable magnification is obtained by changing the distances between elements of the eyepiece and the erecting system of the telescope. A collective lens in the body of the instrument is often one of the elements of the optical system of such an instrument.

#### 4-5. Prisms.

##### a. General.

(1) A prism, unlike a lens, is bounded by plane surfaces and can be designed to deviate, displace, and reflect light in numerous ways. The introductions of prisms into optical instruments permits design variations otherwise impossible.

(2) In fire-control instruments, it frequently is desirable to bend the rays of light through an angle in order to make a shorter, more compact instrument, to bring the eyepiece into a more convenient position or to erect an image. Plane mirrors are sometimes used to change the angles of the light rays but the silvered surfaces tend to tarnish and cause a loss of light which grows more serious as the instrument becomes older. A prism used for the same purpose can be mounted in a simpler and more permanent mount, the angles of its surfaces cannot be disturbed, and it can produce more numerous reflection paths than would be practical with mirrors.

(3) Optical prisms are blocks of glass of many shapes especially designed and ground to permit them to perform the various functions. They are used singly or in pairs to change the direction of light from a few seconds of arc (measuring wedges) to as much as 3600 (Porro prism system).

(4) When the incident rays strike the reflecting surface of a prism at an angle greater than the *critical angle* (para 2-16) of the substance of which the prism is composed, the reflecting surface does not need to be silvered. This surface must be silvered, to insure total reflection, if the incident rays strike it at an angle less than the critical angle.

b. *Right-Angle Reflecting Prism*. Depending upon which reflecting surface is struck by the incident ray, the right-angle reflecting prism will bend the light rays through an angle of 900 or 1800. The manner in which this prism reflects rays through an angle of 900 is illustrated and described in paragraph 2-16e (A and B, fig 2-36) and through an angle of 1800 in paragraph 2-21a(1) (fig 2-43). When used to reflect rays through an angle of 900, the rays are reflected only once with the result that the image is reverted with reflection in a horizontal plane or inverted with the reflection in a vertical plane. When used to reflect rays through an angle of 180°, the rays are reflected twice and a

normal erect image is produced with reflection in a horizontal plane while inverted, reverted image is produced with reflection in a vertical plane.

*c. Porro Prism System.*

(1) Each element of the Porro prism system is a right-angle reflecting prism placed to bend rays of light through an angle of 180°. One element is arranged to bend the rays horizontally and the other to bend the rays vertically; one element reflects the rays into the other (fig 4-9). With one prism in horizontal position and the other vertical, the Porro prism produces an inverted, reverted image. The Porro prism system is used as the erecting system in many fire-control instruments; it is commonly used in binoculars. The sharp corners of these prisms are removed making the ends round. This reduces the weight and lessens the chance of breakage.

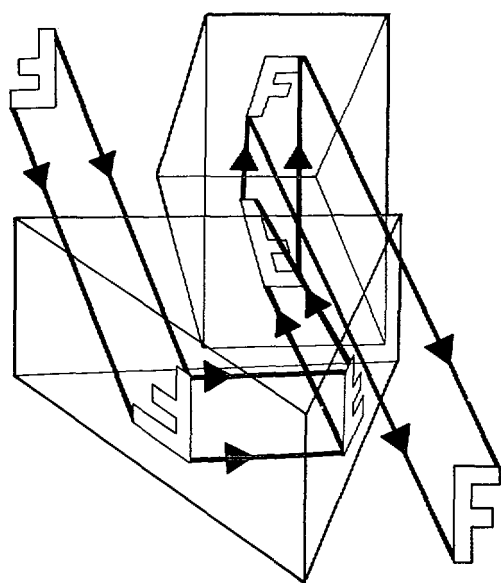

AR910099

Figure 4-9. Porro prism system.

(2) A second type of Porro system is known as the Abbe system (fig. 4-10). It consists of a single system which is three prisms in one or it can be made in the form of two prisms (fig 4-21). It is substantially the same in principle as the first Porro type but the reflections occur in different order. It likewise produces an inverted, reverted image.

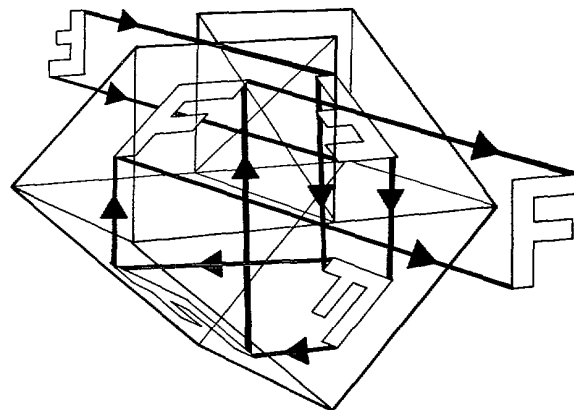

AR910100

Figure 4-10. Abbe system.

*d. Amici or Roof-Angle Prism.*

(1) This is a one-piece prism which may be considered as made up of a right-angle reflecting prism (fig. 2-43) with the hypotenuse face or base replaced by two faces inclined toward each other at an angle of 90° (fig 4-11). The latter two faces form the "roof" and give this prism its name. When inserted in the optical system of a telescope, it bends the light rays within the instrument through an angle of 90° while, at the same time, inverting and reverting the image.



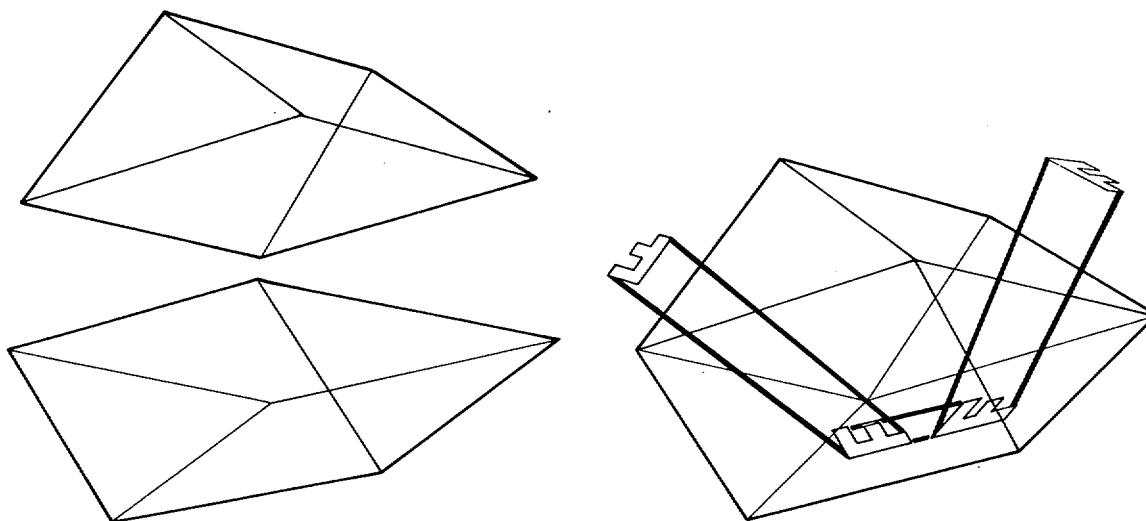

AR910101

Figure 4-11. Amici or roof-angle prism.

(2) When employed as the erecting prism of an elbow telescope (fig 8-11), one of its uses, the light ray enters One short face (fig 4-11) where it strikes the reflecting surface of one side of the roof. It is reflected to the other side of the roof where it is reflected outwardly at right angles to the direction in which it entered the prism.

Usually, the parts of the prism not used by light rays are removed affecting the appearance of the prism but not its fundamental shape or function.

(3) The Amici prism is compact and it transmits a great amount of light but is one of the most difficult of all prisms to manufacture because the angle between the two inclined faces of the roof cannot differ from  $90^\circ$  by more than 2 seconds if the prism is to function satisfactorily.

e. Rhomboidal Prism. The Rhomboidal or Rhomboid prism (fig 4-12) may be considered as made up of two right-angle reflecting prisms built in one piece, or as a block of glass with the upper and lower or two other opposite faces cut at an angle of  $45^\circ$  and parallel to each other. This prism has two parallel reflecting surfaces providing two reflections in the same plane and transmits the image unchanged. It does not invert or revert the image nor change the direction of the light rays but displaces the light rays parallel to themselves.

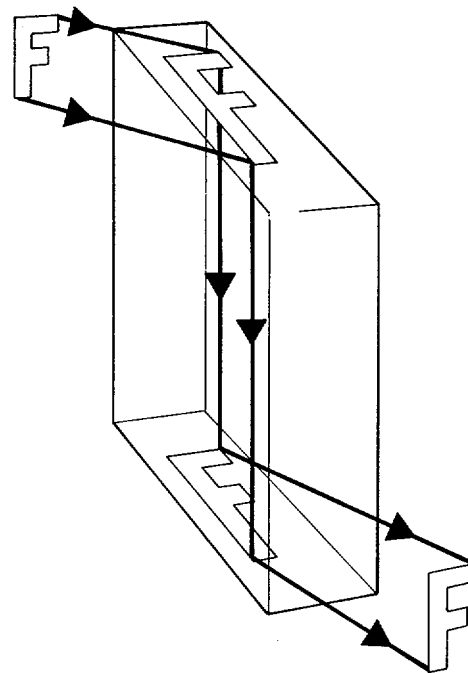

AR910102

Figure 4-12. Rhomboidal prism.

This is due to double reflection without reversal of the direction of light. This result is obtained from mirrors in certain periscopes (fig 8-19). Rhomboidal prisms are employed to shift the lines of sight to secure interpupillary distance adjustment. It is used in the range finder.

f. Rotating Dove Prism. The rotating Dove prism (A, fig 4-13) resembles the rhomboidal prism except that the angles of its ends are opposite to one another and this prism serves an

entirely different purpose. Light rays entering the upper face of the prism are reflected once against the longest face of the prism after which they continue along their original path out of the lower face. The image is inverted only by the single reflection. This inversion of the image is corrected

in panoramic telescopes by a second inversion in the 90° objective prism. When this prism is rotated about its longitudinal axis, the image rotates in the same direction with double angular speed (para 4-7d(4)).

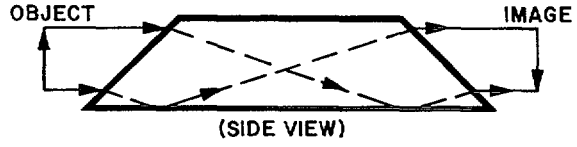
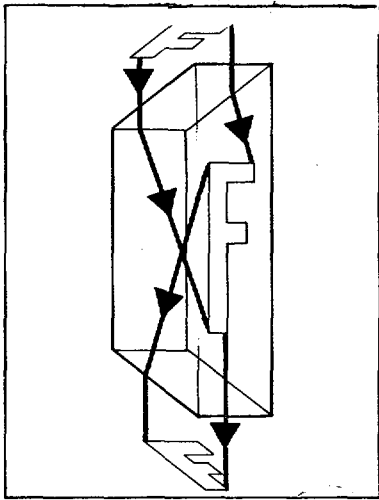

A-DOVE PRISM

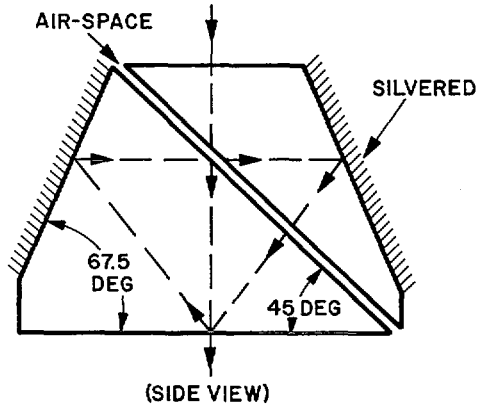
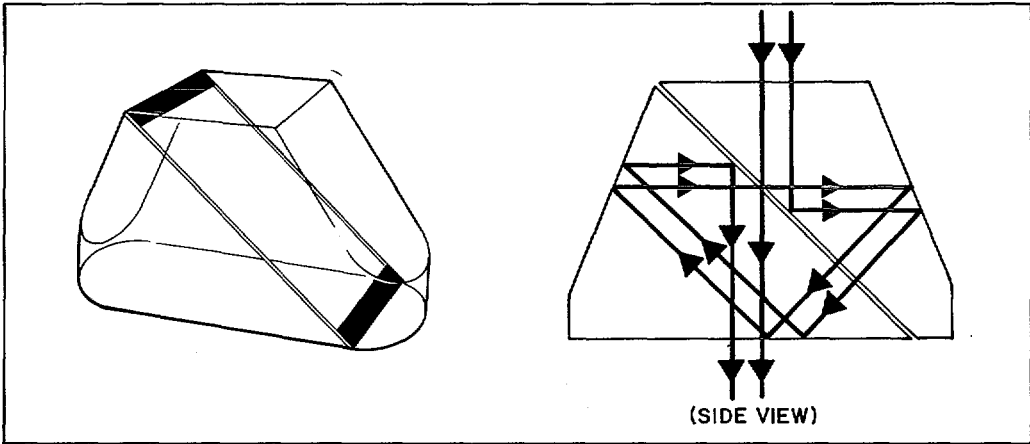

B-PECHAN PRISM

AR910103

Figure 4-13. Rotating prisms.-

*g. Pechan or Z Rotating Prism.* The rotating Pechan or Z prism (B, fig 4-13) consists of two prisms separated at an angle of  $45^\circ$ . Light rays entering this prism assembly are reflected five times before emerging; twice in one element and three times in the other providing reversion because there are five reflections in one plane. The incident rays and the emergent rays are in alignment and travel in the same directions. Two of the external reflecting surfaces must be silvered. When this prism is rotated about its longitudinal axis, the image rotates in the same directions with double angular speed.

*h. Pentaprism or Five-Sided Prism.*

(1) The pentaprism (A and B, fig 4-14) reflects light rays through an angle of  $90^\circ$  by two reflections from two silvered surfaces at a  $45^\circ$  angle to one another. It does not invert or revert the image if reflection takes place in either the

horizontal or vertical plane (the figure shows the front of the object and the rear of the image). This prism is useful in range finders where the angles of the ray must remain constant, it is necessary to reflect light rays through an angle of  $90^\circ$  in a horizontal plane, and the image should neither be reverted nor inverted. The angles measured by the range finder are so small that; if a greater number of prisms were used, any deviation in the angles brought about by slight bending of the tube and consequent rotation of the prisms would be sufficient to impair the accuracy of the instrument. It is necessary to silver the two reflecting surfaces of the pentaprism as the rays strike the reflecting surfaces at angles less than the critical angle and total reflection otherwise would not result. It also is used in elbow telescopes to erect the image and produce the  $90^\circ$  deviation.

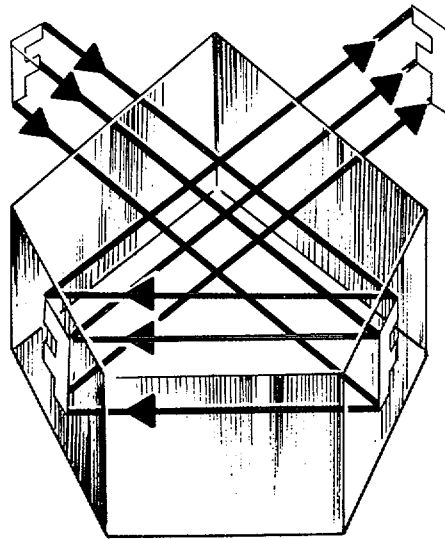

A

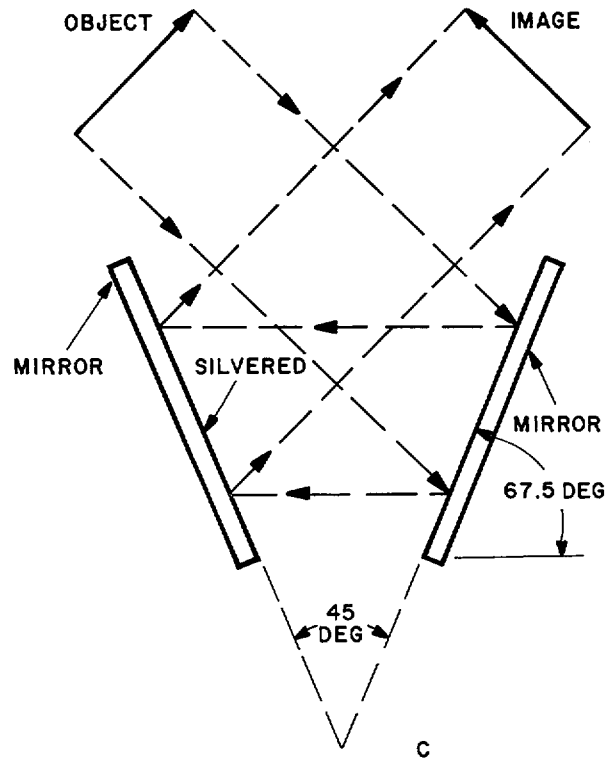
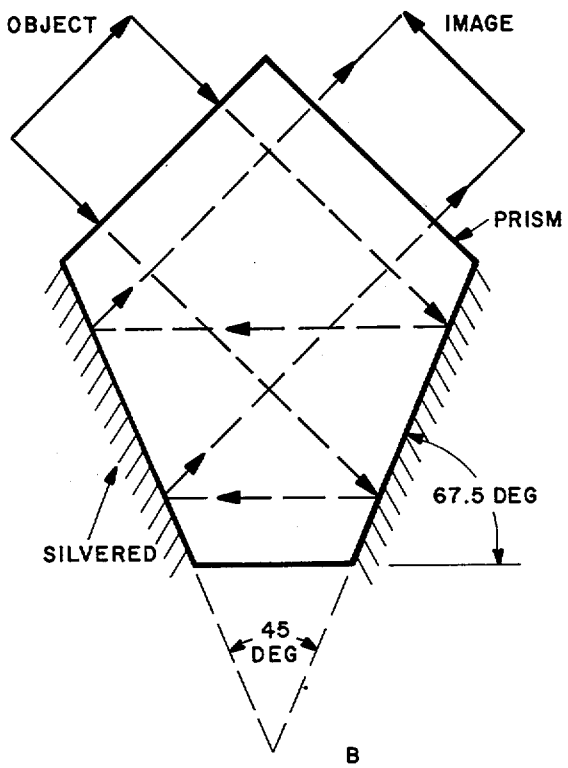

AR910104

Figure 4-14. Pentaprism (diagrams show same effect obtained with mirrors).

(2) In the obsolete long base height finders, the pentaprism that would be required would be so large that it would be difficult to find blocks of glass sufficiently large and homogeneous for the construction of such prisms. Two mirrors were used to replace the two reflecting surfaces of a pentaprism (C, fig 4-14). These mirrors were fastened in a rigid mount at precisely the same angles as the reflecting surfaces of the pentaprism of the same size and produced the same effect. The effects of temperature changes were eliminated insofar as possible to hold the reflecting surfaces in the proper relation to each other.

(3) This prism is known as a constant deviating prism because it deviates light constantly  $90^\circ$  regardless of slight deviation of incident rays from the perpendicular.

*i. Triple Mirror Prism.* The triple mirror prism (fig 4-15) has four triangular faces, any three of which can be reflecting surfaces. It may be considered as consisting of two triangular roofs, one above and one below, with the crests of the roofs at right angles to one another. This prism has the unique property of deviation, through an angle of  $180^\circ$ , any ray of light entering it. If the angles of this prism are accurately made, incident light will be returned back along a course parallel to its original path. It produces an inversion of the image.

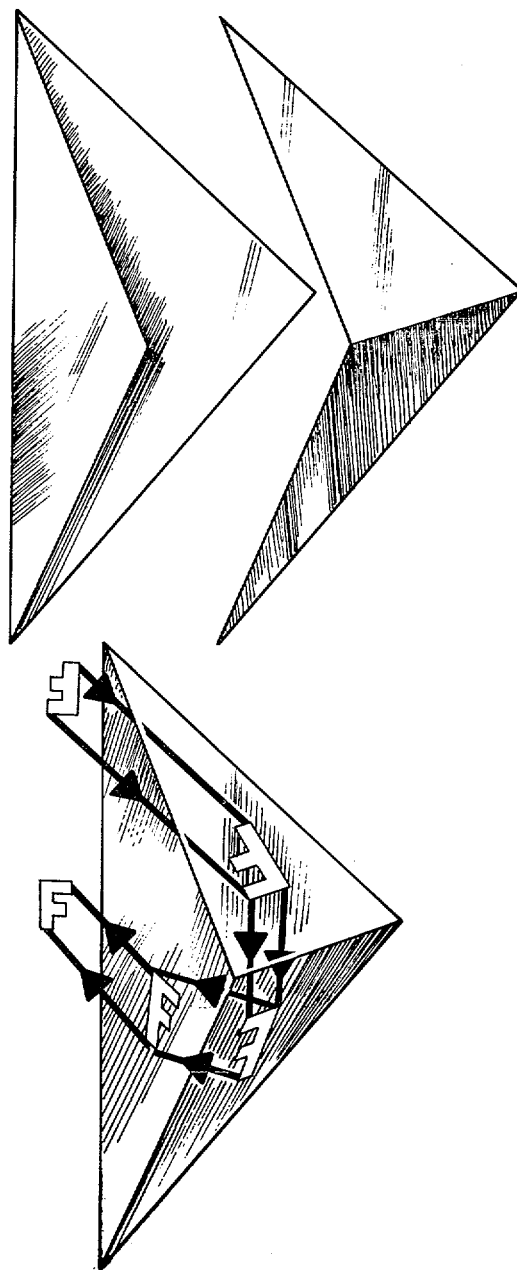

AR910105

Figure 4-15. Triple mirror prism.

j. *Double Right-Angle Abbe Prism.* The double right-angle Abbe prism consists of two right-angle prisms joined as shown in figure 4-16. This prism reflects light twice at right angles to the direction of the incident ray. The image is rotated 90° two times.

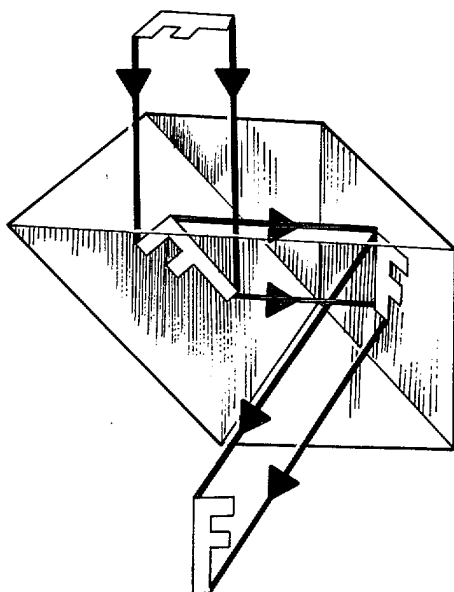
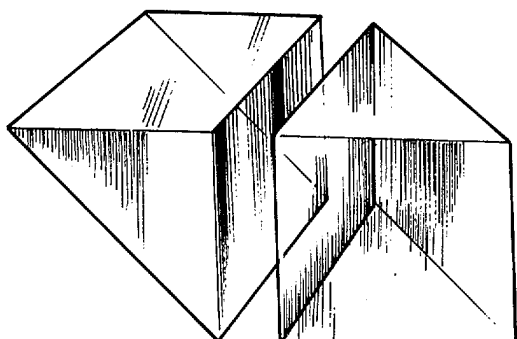

AR910106

Figure 4-16. Double right-angle Abbe prism.

**4-6. Wedges.**

a. The optical wedges used in fire-control instruments are prisms with two plane surfaces at slight angles which divert the paths of light through small angles by refraction instead of by reflection. They are used where the angle of deviation required may be a matter of fractions of seconds and it would not be practical to produce

such slight deviations by means of reflection surfaces. Wedges are used in the measurement systems of range finders and to correct or adjust the alinement of paths of light. They are of two general shapes--rectangular and round.

b. The angle at which a wedge will deviate the path of light is dependent upon the relative slant of its two faces which are inclined toward each other like the surfaces of a common house shingle. Some wedges used in fire-control instruments appear to be plates or disks of glass with parallel surfaces, because the angle between the surfaces is so slight it cannot be detected except by careful examination or by actual measurement.

c. Because deviation of rays of light by wedges is produced by refraction instead of reflection, a certain amount of dispersion or separation of colors results from the use of wedges. For this reason achromatic wedges, composed of two different kinds of glass to neutralize the dispersion, must be used where the angles through which the rays are bent are relatively large or where the work performed by the wedges is of the most exacting nature.

d. All wedges cause a certain deviation of the path of light. Instruments employing wedges are sometimes designed so that the path of light entering the wedge has a certain amount of initial deviation which is termed the constant deviation. The constant deviation makes it possible for the wedge to neutralize the deviation in the path of light or divert the light at a minus angle.

e. A wedge may be caused to change the path of light in various directions by rotation of the wedge (fig 4-17). The extent to which a wedge may be made to divert the path of light may be varied, likewise, by changing the position of the wedge with relation to the other elements of the optical system (fig 4-18).

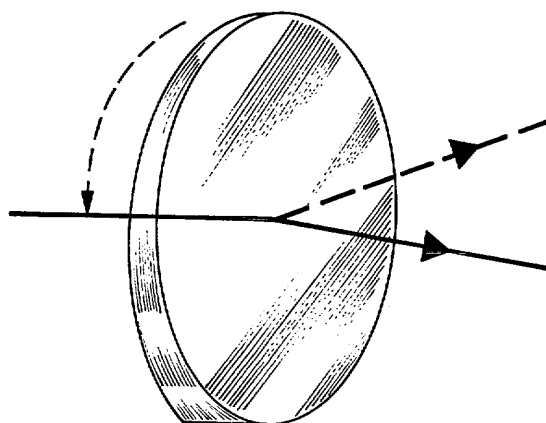

AR910107

Figure 4-17. Rotation of wedge changes direction of path of light.

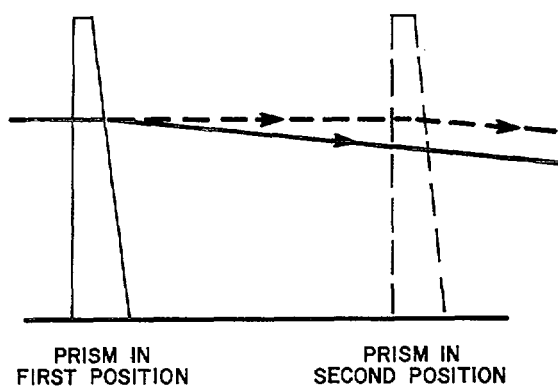

f. Another means of varying the path of light is through the use of pairs of wedges which are geared to rotate in opposite directions. The wedges of such a system are referred to as rotating wedges or rotating compensating wedges. When the thicker edges of two of these wedges are together (A, fig 4-19), they produce a deviation twice that of one wedge and in the direction of the thicker edges of the wedges. When rotated until the thick edge of one wedge is toward the thin edge of the other (B, fig 4-19), the wedges neutralize one another and the wedges produce no deviation. Intermediate positions cause a deviation which increases as the thick edge of one wedge rotates farther from the thin edge of the other. When both wedges are rotated through  $180^\circ$  (C, fig 4-19), the thick edges again are together and the wedges function as in A, figure 4-19, except in the opposite direction.

AR910108

Figure 4-18. Extent of displacement of light may be changed by movement of wedge.



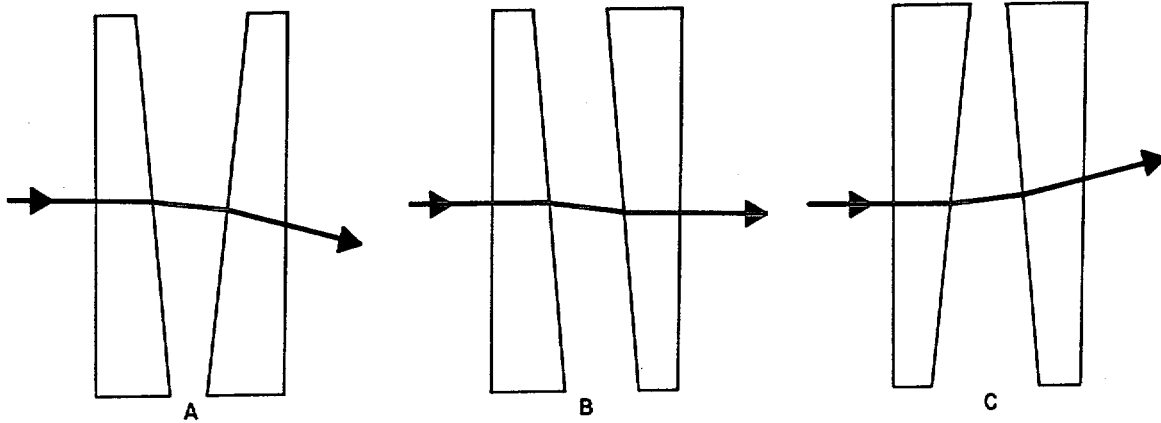

AR910109

Figure 4-19. Principles of rotating measuring wedges.

**4-7. Erecting Systems.**

*a. General.*

(1) The image generally is reverted and inverted by the objective.

(2) The function of the erecting system is to bring the image upright and correct reversion.

*b. Types.* Erecting systems are of two general type, lens and prism. While most lens erecting systems are of the same general design, differing only in the types of lenses used and the spacing of the elements, the prism erecting systems employ elements of a wide variety of shapes causing the rays of light to be diverted in different paths in the different systems.

(1) A lens erecting system greatly increases the length of an instrument. It is often used where

length in the optical system is a distinct advantage as in periscopes. This system also is employed in instruments with variable magnification because different degrees of magnification can be obtained by changing the relative positions of the lenses.

(2) Where compactness of instrument is a desirable feature, a prism erecting system is used. Such a system may consist of a single element or several. The great reduction of length resulting from the use of a prism system is due to the doubling back of the path of light. The prism erecting systems in most general use employ Porro and Abbe prisms, the Amici or roof prism, and single and double right-angle prisms.

*c. Lense Erecting Systems.*

(1) The simplest form of lens erecting system

places a second convex or converging lens in the proper position to pick up the inverted image framed by the objective and forms a second erect image which is magnified by the eyepiece (upper, fig 4-20). In most

fire-control instruments, a lens erecting system of two and sometimes three lenses is substituted for the single erecting lens (lower, fig 4-20). The entire lens erecting system functions as a single lens.

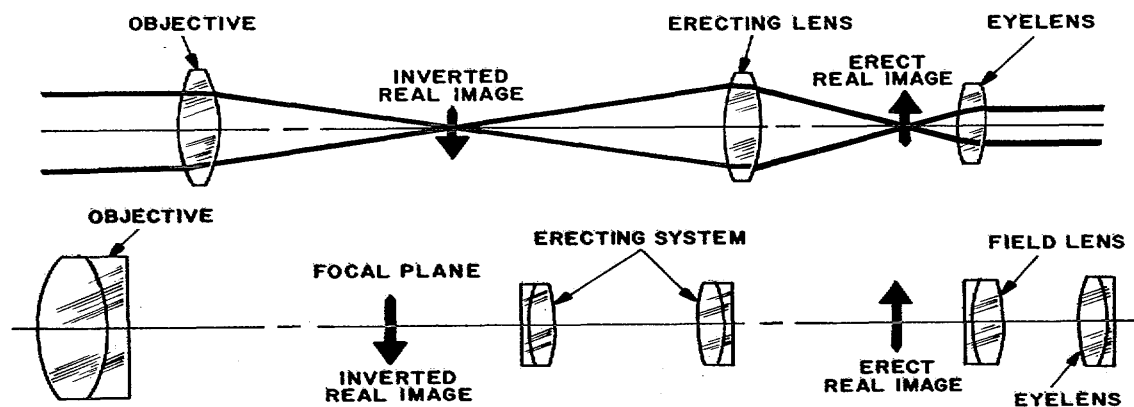

AR910110

Figure 4-20. Lens erecting systems.

(2) In a two-element lens erecting system, both lenses usually are of compound (achromatic) type. In a three-element system, the third lens is of planoconvex or double-convex type and serves as a collective lens. It converges the light rays of the image formed by the objective so they will pass through the erecting lenses. It increases the field of view and brightness of image for a given diameter of the lenses of the erecting system. Inasmuch as the collective lens is sometimes placed at the point where the image of the objective lens is formed, and a reticle must be placed at this same point, the reticle markings are simply engraved on the flat face of the planoconvex lens used as the collective lens.

(3) According to the placement of the erecting lenses, a lens erecting system may increase or decrease the magnifying power of the instrument or it may not affect magnification. Moving the erecting lenses closer to the focal point of the objective lens and farther from the eyepiece increases the magnification but cuts down the field of view. When the erecting lenses are located at equal distances from the focal points of the objective and the eyepiece there is not additional magnification due to erecting lenses. This method of changing the degree of magnification is employed in instruments of variable power.

#### d. Prism Erecting Systems. Prism erecting

systems function by internal reflection. With the exception of rotating prisms, if the path of light is to continue in an unchanged direction, a total of four reflections is required.

(1) *Porro erecting system.* This system (fig 4-9) is employed in prism binoculars and in a number of telescopes. It tends to decrease the curvature of the field and its use is particularly advantageous when a compact instrument having a large field of view is desired as is the case in observation telescopes. This system is not well suited to telescopes which are to be mounted on gun carriages as the prisms are of awkward shape and it is difficult to clamp them so tightly that they will not shift their positions when the gun is fired. In some periscopes and in the battery commander's periscope, the 900 prisms in the heads together with the lower prisms constitute a Porro prism erecting system.

(2) *Abbe erecting system.* This erecting system (fig 4-21) employs two double right-angle prisms (fig 4-16). The two prisms are assembled in the instrument to give the same optical effect as in the three piece Abbe prism (fig 4-10). The two prisms are not joined, a slight amount of space being left between them. This system, which inverts and reverts, is used in some telescopes, including those incorporated in periscopes, as an erecting system.

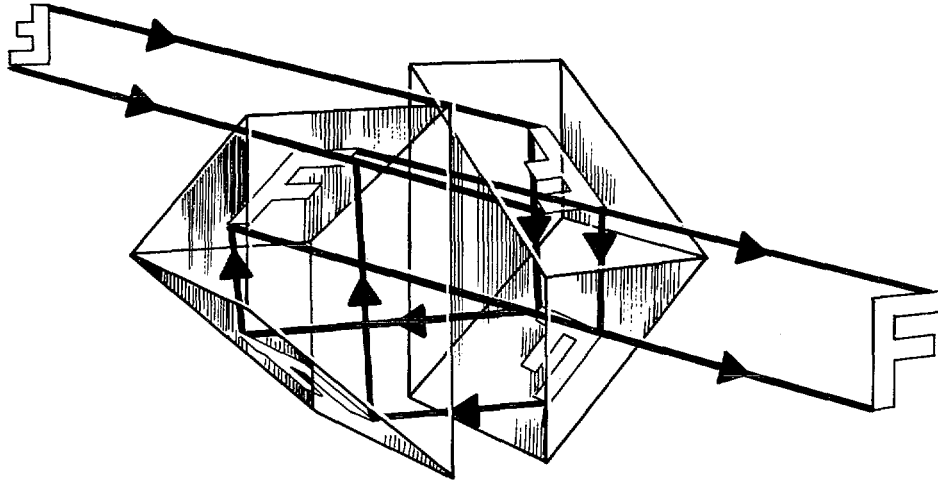

AR910111

Figure 4-21. Erecting system using two double right-angle Abbe prisms.

(3) Amici or roof-angle prism. When used in an elbow telescope, this single prism (fig 4-11) serves as an erecting system as well as a right angle prism. By its use the light rays are diverted through the right angle of the telescope and the erection of the image is

secured by reflection on two of its surfaces. It can be mounted securely and thus is suitable for telescopes are mounted on gun carriages. Combined with a rotating prism and a right-angle prism it is used in the erecting system of panoramic telescopes (fig 4-22).

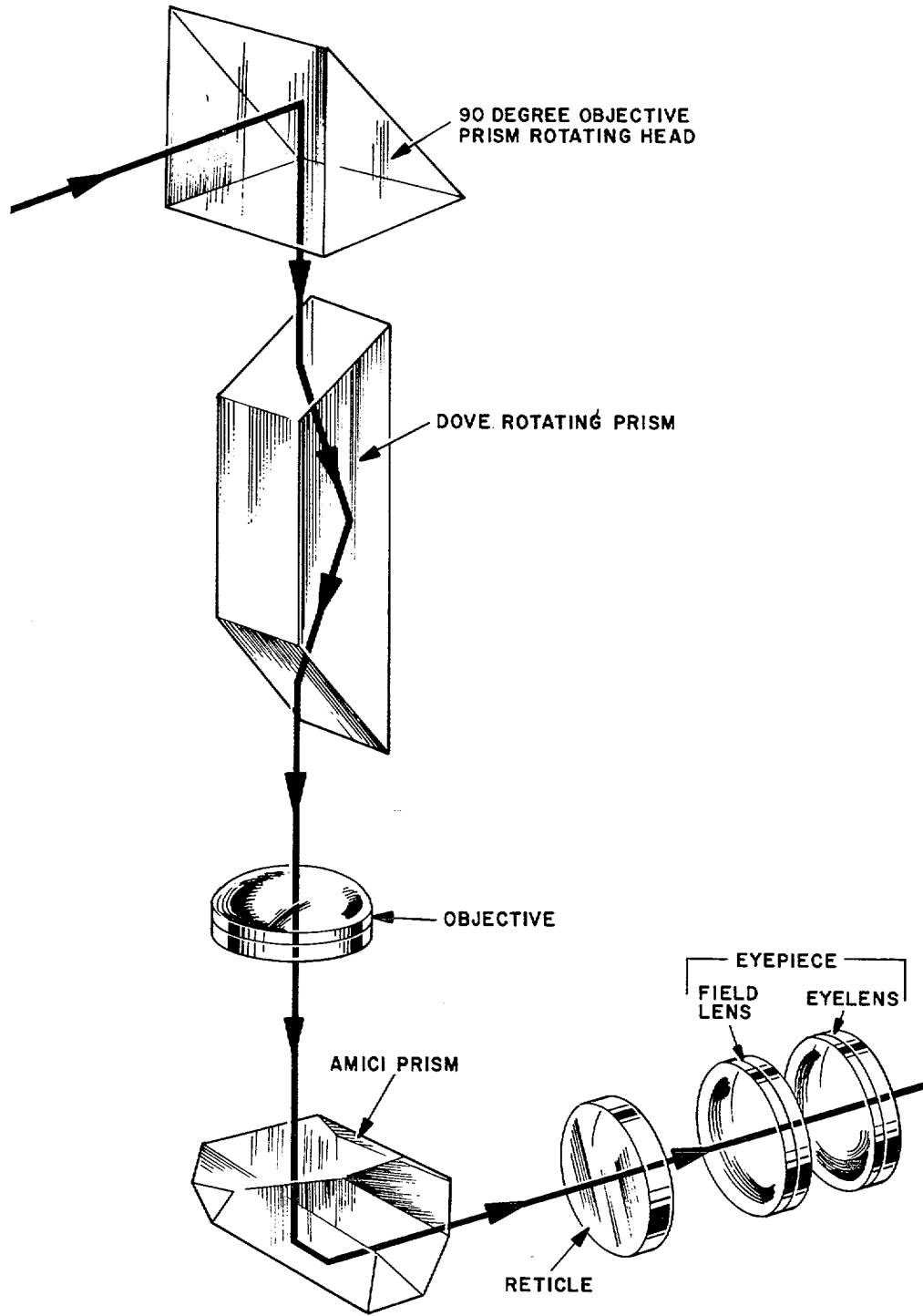

AR910112

Figure 4-22. Optical system of panoramic telescope.

(4) *Dove rotating prism.*

(a) The Dove rotating prism (A, fig 4-13) is the means by which the image in some panoramic telescopes is caused to remain erect as the head of the instrument is rotated. It usually is placed either outside the telescope system proper or between symmetrical erectors. The line of sight of the rotating head can be revolved in azimuth  $360^\circ$  (a complete circle) while the eyepiece is fixed so that the observer does not move. Some panoramic telescopes (fig 8-16) employ the objective  $90^\circ$  prism in the head, and the Dove (rotating) prism is caused to revolve in the same direction and through one-half the arc of the  $90^\circ$  prism in the head. The field, inverted by the objective  $90^\circ$  prism, and again inverted by the Dove prism, also is rotated through twice the arc of travel of the Dove prism itself as illustrated in figure 4-23.

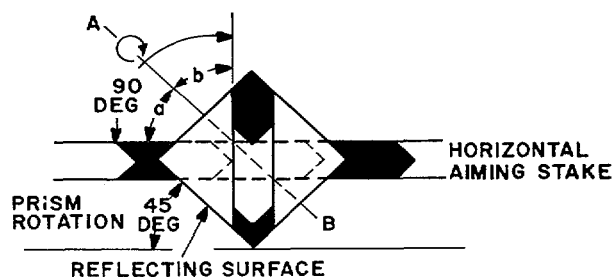

AR910113

Figure 4-23. Image rotation in Dove prism (end view).

(b) An object such as a vertical aiming stake will appear upside down when viewed through a Dove prism positioned with its long face horizontal. When looking forward through the panoramic telescope this inversion corrects that initially introduced by the  $90^\circ$  prism in the head. As the panoramic head prism is revolved from this forward looking position, it introduces angular tilt equal to its angular rotation so that when it is turned to look to the user's left (for example) a vertical aiming stake will become horizontal in the image. Since the rotation, or tilt, of the field image produced by rotation of the Dove prism is twice the rotation of the plane of the reflecting surface (in accord with the law of reflection), this  $90^\circ$  tilt will be eliminated by a  $45^\circ$  rotation of the Dove prism.

(c) As an example, consider a horizontal

aiming stake viewed through a horizontal Dove prism positioned with the reflecting face at  $45^\circ$  angle to the horizontal (fig 4-23). Since the image is reverted in the plane of reflection, it can be considered to revolve about the axis AB, which is parallel to the reflecting surface. In this case, angle "a" is  $45^\circ$ ; therefore, angle "b" is  $45^\circ$  and their sum is  $90^\circ$  or twice the angular rotation of the prism itself. When the  $90^\circ$  prism (in the panoramic head) is turned  $180^\circ$ , it will transmit an upright but horizontally-reverted image to the Dove prism. Because the field is behind the observer, the effect is the same as in viewing the user in a mirror where the user's image appears reverted horizontally. In order to provide a normal image, the Dove prism is so positioned by the  $90^\circ$  rotation of the plane of reflection that horizontal reversion occurs.

(d) As both incident and emergent rays are refracted by a Dove prism, it must be fed by parallel light, otherwise an aberration is introduced. For this reason it is usually placed outside (in front of) the telescope system proper. If it is desired to place a rotating prism within a telescope system where rays are not parallel, the Pechan prism is used as its incident and emergent faces are perpendicular to its surfaces and it is, therefore, not a refracting prism and will not cause aberrations. If it is desired to introduce a Dove prism within a telescopic system, it must be placed between erectors so positioned that principal rays between erectors are parallel.

(5) Pechan or Z rotating prism. The Pechan or Z rotating prism (B, fig 4-13) can be used, similar to a Dove rotating prism, as a rotating prism in panoramic telescopes to maintain an erect field by neutralizing the reverting effect of the objective prism and when the rotating head is turned (4) above). When this prism is rotated about its axis, the image rotates in the same directions with double angular speed. By rotating the prism, erection of the image is accomplished.

**4-8. Mirrors.** The mirrors used to reflect the paths of light in fire-control instruments are not the common household type made of plate glass. The reflecting surfaces on household mirrors produce a faint reflection from the front glass surface in addition to that produced by the silvered back. To eliminate this "ghost image," the reflecting surfaces of optical mirrors are placed on their front faces. Mirrors of this type are termed front surface mirrors. The reflecting surface is a thin film of metal chosen for its resistance to tarnish. Such mirrors must be handled carefully as they can easily be scratched and become useless until they can be resilvered or realuminized.

**4-9. Reticles.**

a. The majority of reticles (para 5-19) are glass disks with plane parallel surfaces. Appropriate markings are engraved or etched on one of the surfaces. In some cases, a planoconvex lens is required at the point where the reticle would be mounted. In such cases, the markings are engraved on the plane surface of the lens.

b. Military reticles are of several types: wire (or some filament material), a post (picket), an etching on a plate glass or lens surface, or a punched metal

plate as in a reflex system.

(1) Crosswires (A, fig 4-24), commonly used in rifle scopes, give increased light transmission by eliminating one piece of glass. With a wire reticle, there is no glass surface present to become dirty and require cleaning. Crosswires may be cleaned with little effort by using a camels-hair brush dipped in carbon tetrachloride. A dirty glass surface in the image or reticle plane is in sharp focus and under magnification. Such a glass reticle surface, therefore, must be clean.

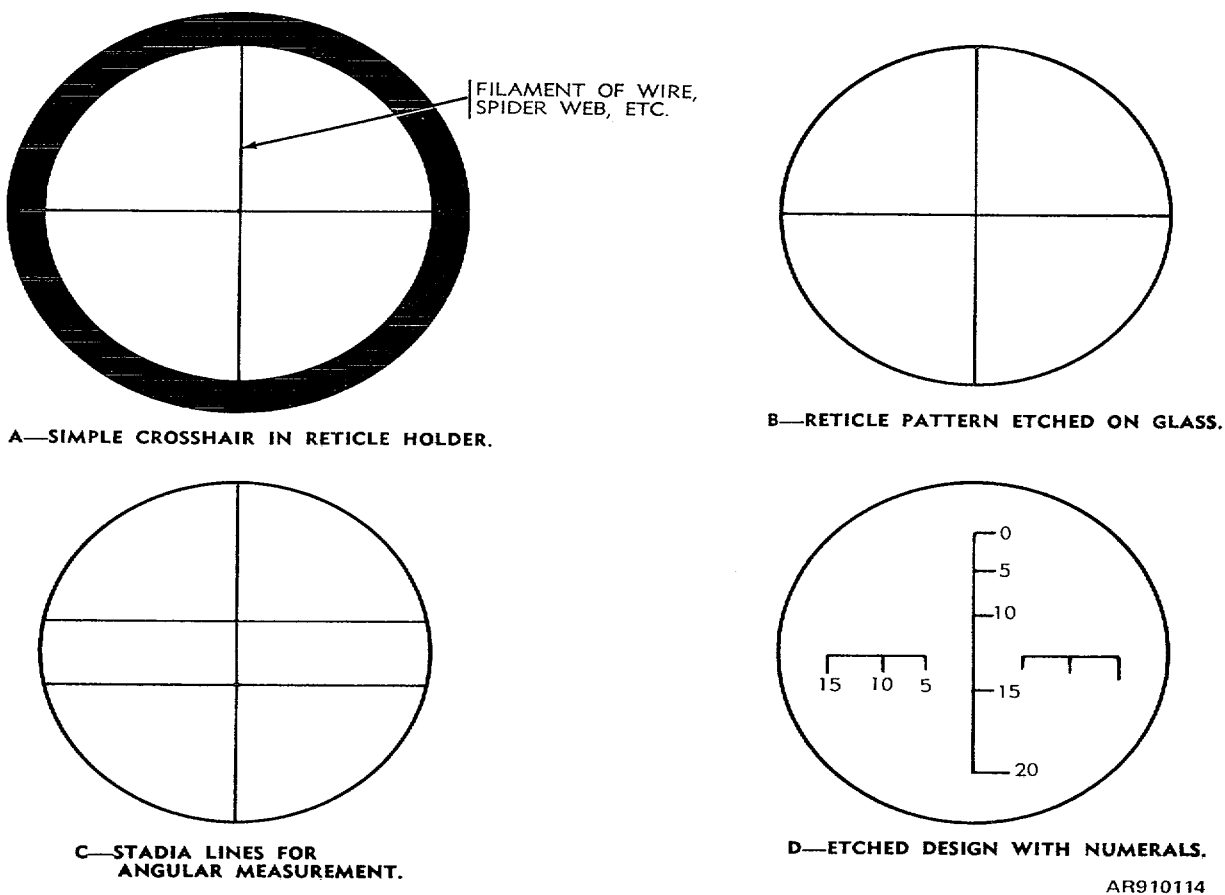

Figure 4-24. Representative types of reticles

(2) Reticles on glass commonly are used in most military sights. The reticle pattern is etched and filled on a planoparallel plate so that it is seen as a black silhouette. If illuminated, it will glow with reflected light.

Glass provides a surface for any desired reticle design or pattern as illustrated in B, C, and D, figure 4-24. This glass surface must be perfectly clean as it is in a focal place and all dirt is in perfect focus and magnified. A

*lensatic retical* (reticle-lens) is one etched on the plane surface of a collective or field lens.

c. There are many different types of reticle patterns (fig 4-25) designed for different purposes. The reticle of an instrument designed for use on a particular weapon, when used with specific ammunition, is

identified by a group of small figures and letters which appear near the bottom or top of the field of view (C and E, fig 4-25). These figures and letters may be *firing table numbers* or *F.T. numbers* to indicate the firing table used in designing the reticle or may be other characteristic identification information.

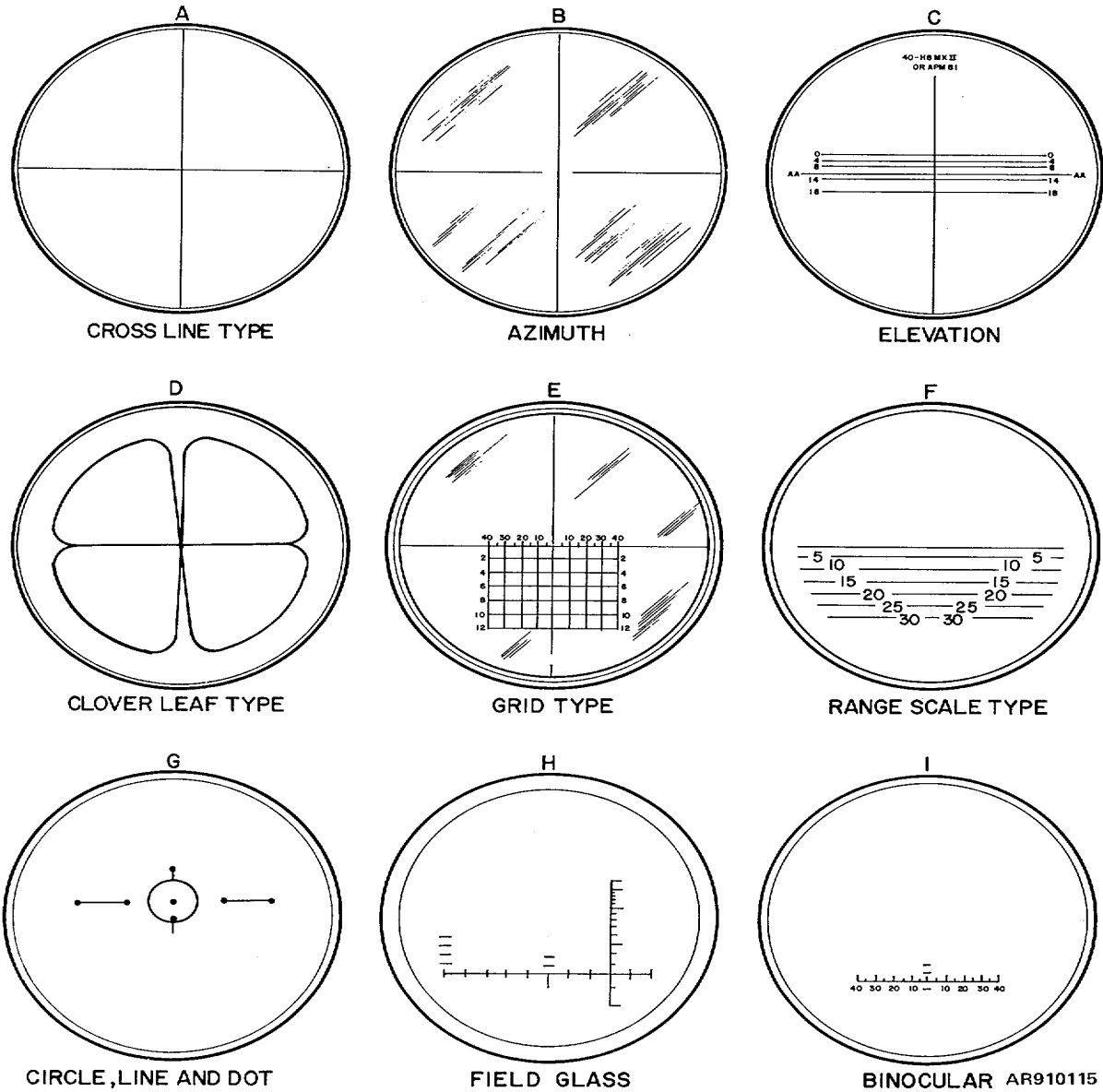

Figure 4-25. Representative types of reticle patterns.

#### 4-10. Diaphragms or Stops.

a. General. Diaphragms are rings of opaque material placed in an optical system so that light passes through their centers. As their apertures limit the field of view they are sometimes called field stops. When placed around the edges of lenses, they prevent rays from passing through the margins of the lenses and causing aberrations. When placed between the objective and the erecting system or between the erecting system and the eyepiece, or in both or these positions or between parts of the erecting system, they eliminate marginal rays which would otherwise cause glare and haze by reflecting from the inside walls,

or ghost images caused by internal reflections from curved lens surfaces.

##### b. Antiglare Stops.

(1) Antiglare stops improve contrast by preventing rays exterior to the field from bouncing off the interior of the instrument and fogging the field or causing glare ray (2, fig 4-26). Nonreflecting paint and baffle finish on inner wall of the tube likewise eliminate most of this undesired light. Light from a brilliant source may still be reflected off a dark wall and cause serious trouble especially with a glass reticle. This is particularly true in wide-angle telescopes and aircraft instruments which may be pointed toward the sun.

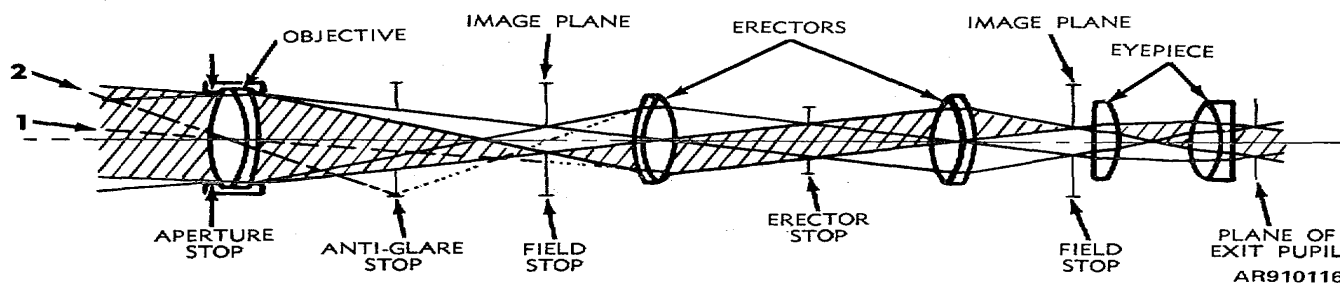

Figure 4-26. Diaphragm (stop) location.

(2) In straight-tube telescopes, the stops are merely washers or disks with a hole in the center. The prism shelf in a binocular is designed to act as a stop. The groove in the face, the rounded corners, and flattened apex of Porro prisms are designed to function as stops.

(3) Antiglare stops usually are located between the objective and the erectors or wherever an image of the aperture stop is formed (fig 4-26). They are known as erector stops if they are located between erectors. Such stops provide balance illumination by limiting the rays from the center of the field to the same area as those from the edge of the field.

c. *Field Stops.* The field stop (fig 4-26) limits the field to that area which is fully illuminated and sharply focused by eliminating the peripheral region of poor imagery (caused by aberrations) and also prevents the observer from viewing the inside of the instrument. It is located in an image plane providing a sharply defined limit to the field. It is designed to admit all the light or limiting rays needed by the next element whether erectors or eyepiece. The field stop also may function as an antiglare stop preventing rays exterior to the field from being reflected off inner surfaces back into the field (ray 1, fig 4-26). If a field stop is used in each image plane, the second such stop is slightly larger than the

image of the first at that point so that slight inaccuracy in size or positioning will not conflict with the sharply defined image of the first.

d. *Aperture Stops.* In telescopes, this stop (fig 4-26) usually is the objective lens cell or retaining ring as there is no reason for reducing the size of the aperture of the single compound objective lens usually used in such an instrument (as contrasted with the need for such stops in wide-angle camera lenses to reduce aberrations). A stop in close proximity to such a single compound lens objective would only reduce the illumination and exit pupil size (the same as using a smaller lens) without reduction in aberrations from the lens area used. In a complex objective (two or more separate lenses), however, a stop located between the lenses may reduce aberrations. Also, in a complex eyepiece of several elements, a stop between the elements may serve to reduce aberrations.

e. *Field Effects.* All stops, excepting an objective aperture stop, can be considered to limit the field since they may prevent rays exterior to the field from reaching the eye. In designing a system, however, this field limit is determined from the apparent field of the eyepiece so that in the final analysis the true field of the instrument must be governed by the eyepiece.



#### 4-11. Filters.

a. *General.* Filters or ray filters are colored glass disks with plane parallel surfaces. They are placed in the path of light through the optical system of a fire-control instrument to reduce glare and light

intensities. They are provided as separate elements which may be attached and detached (A, fig 4-27) or are mounted so they may be placed in or out of position as desired (B and C, fig 4-27).

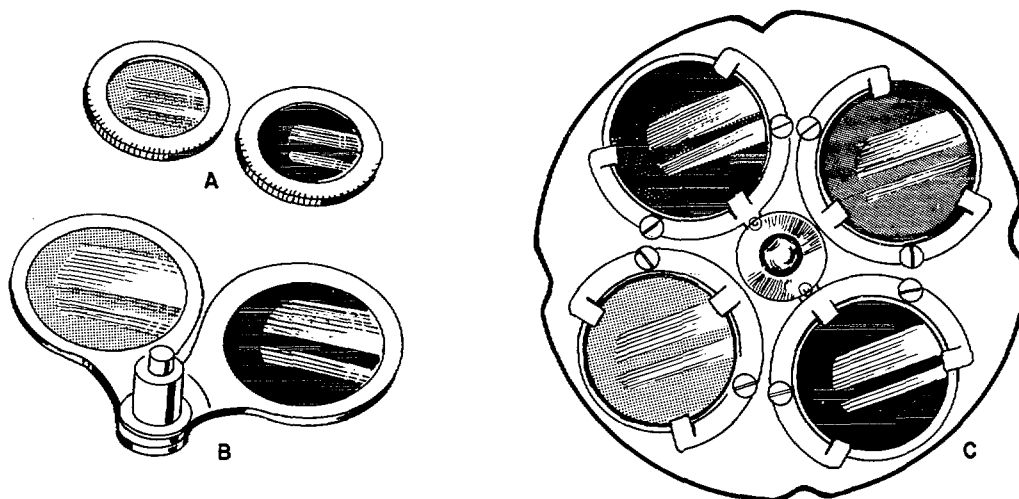

AR910117

Figure 4-27. Types of filter mountings.

b. *Colored Filters.* Filters of various colors are used to improve visibility under different atmospheric and light conditions. Among the colors of filters used are: smoke, yellow, amber, blue, red and greenish-yellow.

(1) The smoke (neutral) filter reduces the intensity of light and is effective when observing against or in close vicinity of sun or a searchlight; usually it is too dark for other purposes.

(2) The yellow and amber are used to protect the eyes from the reflection of sunlight on water and other general conditions of glare.

(3) The amber and red filters are usually employed under various conditions of fog and ground haze. Red filters are also used in observing tracer fire.

(4) The blue filter is helpful in detecting the outlines of camouflaged objects.

(5) The greenish-yellow filter is intended to serve the purpose of both smoke and amber.

c. *Polarizing filters.*

(1) Polarizing filters do not change the color of objects but merely decrease light intensity and are used to eliminate glare. When mounted in pairs, they can be used to provide continuous control of light intensity.

(2) Light polarizing substances can be considered as being made up of very minute parallel bars or grain (A and C, fig 4-28). Light vibrates in waves with the crests of the waves in all directions. A polarizing substance, placed in the path of the light, permits waves vibrating parallel to the direction of the grain to pass through; waves vibrating at right angles to the bars or grain are stopped (B, fig 4-28). By eliminating a portion of the light, the intensity of the light is decreased. When two polarizing substances are held with the grain of one at right angles to that of the other, no light passes through. By shifting the substance to intermediate angles, light at different degrees of intensity is permitted to pass through.

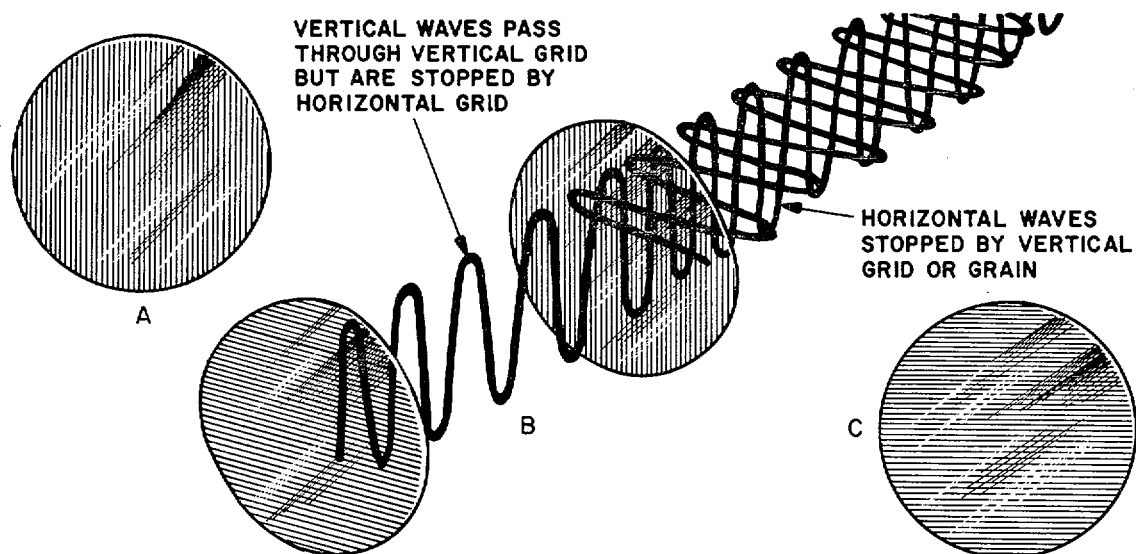

AR910118

Figure 4-28. Principles of polarization of light.

(3) Glare is due to light which is reflected from smooth or wet horizontal surfaces. It can be very annoying and detrimental to clear vision. Such light as being reflected at a glancing angle from a smooth horizontal surface is found to be also polarized in the horizontal plane, the vertical waves being substantially eliminated. A polarizing filter consisting of vertical grain or grid will destroy the remaining horizontal component of that portion of the light which causes glare while permitting normal vision to continue practically unobstructed. The principal function of polarizing filters is to eliminate glare in the field of vision.

#### 4-12. Lighting.

a. The reticles of fire-control instruments require illumination for night operation and under certain conditions for day operation in order that their markings may be seen clearly.

b. Reticles are edge-lighted. The markings are etched or engraved into the surface of the glass. When light is introduced at the edge of the reticle, it travels through the glass and is diffused at these etched or engraved marks illuminating them. Light is introduced at the edges of the reticles through small glass windows set in openings in the body of the instrument. At night, tiny shielded electric lamps are placed over the windows.

c. Lucite is a transparent plastic having the property of transmitting light which enters one end of a rod of this material. The light travels from end to end of the rod with little loss through the outside surface, despite the fact that the rod may be bent. Lucite is employed in the lighting systems of a number of instruments (fig 4-29).

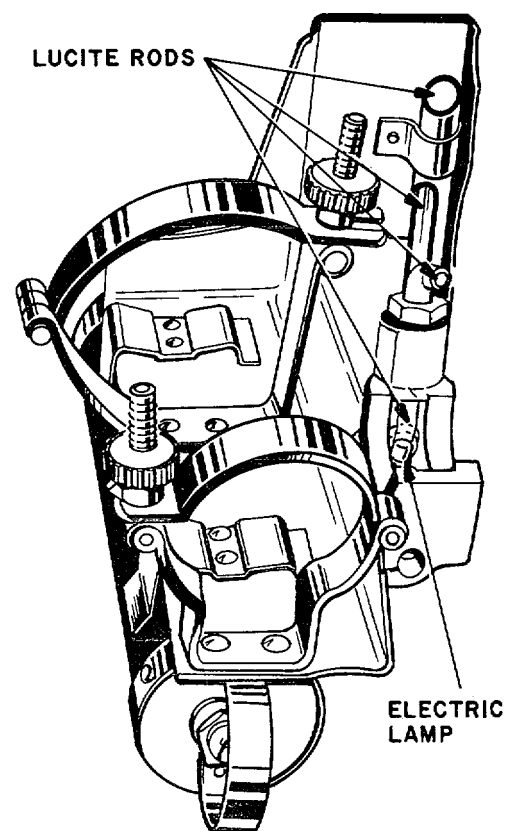

AR910119

Figure 4-29. Instrument light for panoramic telescope.

d. Instrument lights for the majority of fire-control instruments are detachable. They consist of a container for one or more dry-cell batteries, a light switch which is sometimes combined with a rheostat, a clamping arrangement, and a miniature electric bulb with facilities for directing the illumination to one or more points on the instrument (fig 4-29). Some systems have an additional "finger light" (fig 4-30) to permit directing light to any part of the instrument.

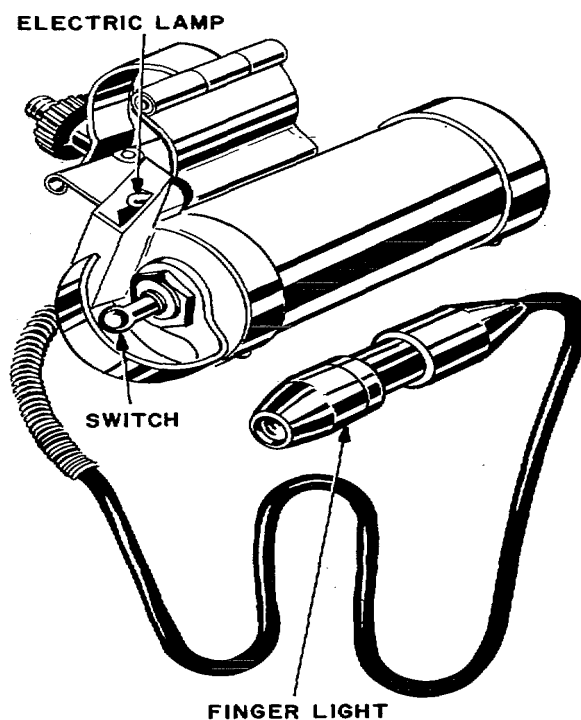

AR910120

Figure 4-30. Instrument light for BC periscope.

e. Some instrument lights are not supplied with dry-cell batteries, but use the vehicle power source.

## Section II. COATED OPTICS

### 4-13. Introduction.

a. Light loss by absorption and scattered dispersive reflection on a silvered surface is about 7 percent. Whenever light strikes an ordinary glass surface, most of the light is transmitted through the glass and undergoes refraction. However, even under the most favorable conditions generally about 4 to 6 percent of the light is lost by reflection from the surface. This loss takes place when light passes from glass to air as well as when light passes from air to glass.

b. This condition occurs at each optical surface of the elements in a fire-control instrument. For example, in a straight telescope with 6 optical elements there are 12 surfaces at which there is reflection and loss of light. Consequently, if each surface transmits 96 percent of the light which it receives, only about 60 percent of the

light which enters the telescope is transmitted to the eye; the remaining 40 percent is lost by reflection and absorption at the surfaces of the various elements. The result is that the image becomes dimmer, the stray reflections produce glare which reduces contrast, and "ghost images" are produced when viewing bright objects at night due to reflection from the curved lens surfaces.

c. A process has been developed for coating the air-to-glass surfaces of optical elements with a very thin film of transparent substance. The coating reduces the loss of light by reflection from each optical interface surface to less than 1 percent (about 1/2 percent), resulting in a corresponding increase in the amount of light transmitted through the element. Optical elements so treated are termed coated optics.

d. A number of types of coating have been tested and applied to optical elements. Some have proved too soft to stand up under handling in normal use and service. The present transparent coating consists of magnesium fluoride applied by an evaporation method of sublimation under heat in vacuum. The coating is durable enough to permit handling during assembly and disassembly and to withstand careful cleaning.

e. The main advantages of coating are as follows:

(1) *Increased light transmission.* When all elements of a straight telescope are coated, except the reticle and filters, there is approximately 90 percent transmission of light instead of 60 percent, or half again as much light as would pass through the instrument were its optics uncoated. This improvement will result in a brighter image at times when light is scarce. It will be most obvious at dawn, dusk, or at night; in other words, at times of poor visibility. Targets are visible from 1/4 to 1/2 hour longer at dusk and at dawn. The range of vision at night is increased approximately 20 percent for standard binoculars. Therefore, coating is essential in night glasses or in instruments to be used under adverse conditions and now is used in all military optical systems.

(2) *Reduction of haze.* Light reflected from

the surfaces of optical components in an instrument tends to throw a veil of stray light over the field of view. Coating will reduce these internal reflections. Better contrast and sharper definition of the image will be the result even under intense illumination.

(3) *Reduction of ghost images.* Internal reflections from the curved lens surfaces sometimes form an image or series of images which are slightly out of focus and not quite as bright as the image of focus. These ghost images are very distracting for proper aiming. Coating will greatly reduce the formation of ghost images.

(4) *Reduction of front surface reflections.* Reflections from the front surface of observation instruments are very noticeable at night and might give the observer's position away. By reducing reflections by means of coating, this danger is reduced.

#### 4-14. Theory.

a. Consider a tiny portion of a light ray so highly magnified as to show its wave structure. A ray of light striking an uncoated glass surface could then be pictured as a wavy line as shown in figure 4-31. The reflected ray, which can represent 4 percent of the total light, is represented by the wavy dotted line and will shift in phase 180° (reverse direction of vibration).

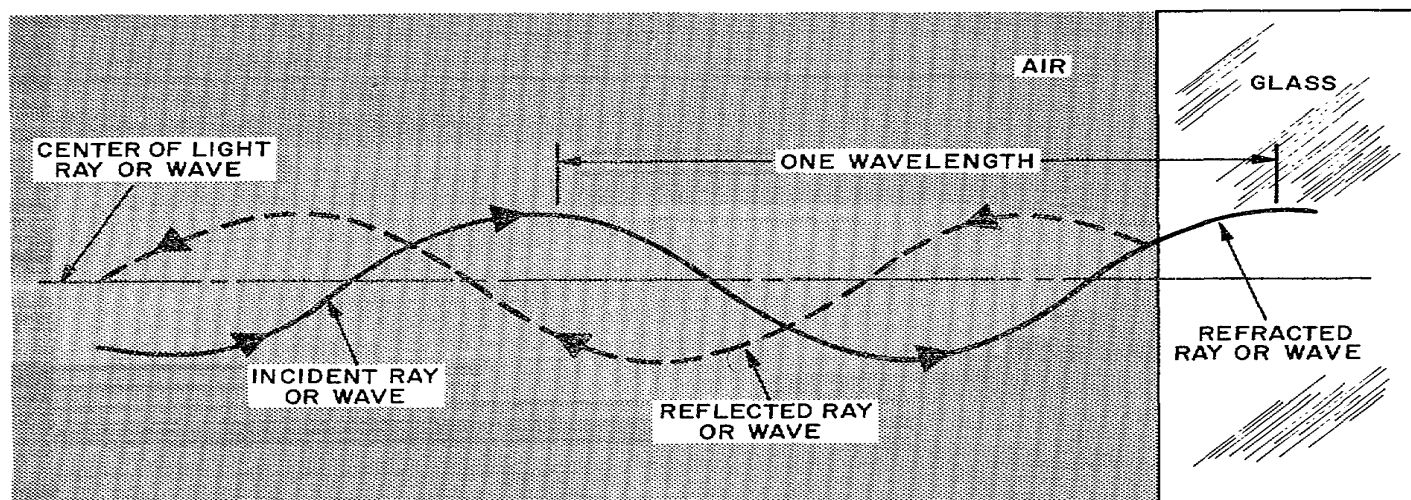

AR910121

Figure 4-31. Light ray striking uncoated surface.

b. If a thin film of transparent substance were placed on the glass, there would be two surfaces from which the wave would be reflected and similarly shifted in phase 180°. If this film were one-half as thick as a wavelength of light, the reflected waves from the two surfaces would follow the same path (fig 4-32). In doing

so, they would reinforce each other resulting in the double amount of light being reflected and the minimum amount of light being transmitted through the surfaces. This condition would be desirable in a reflector but undesirable in a lens.

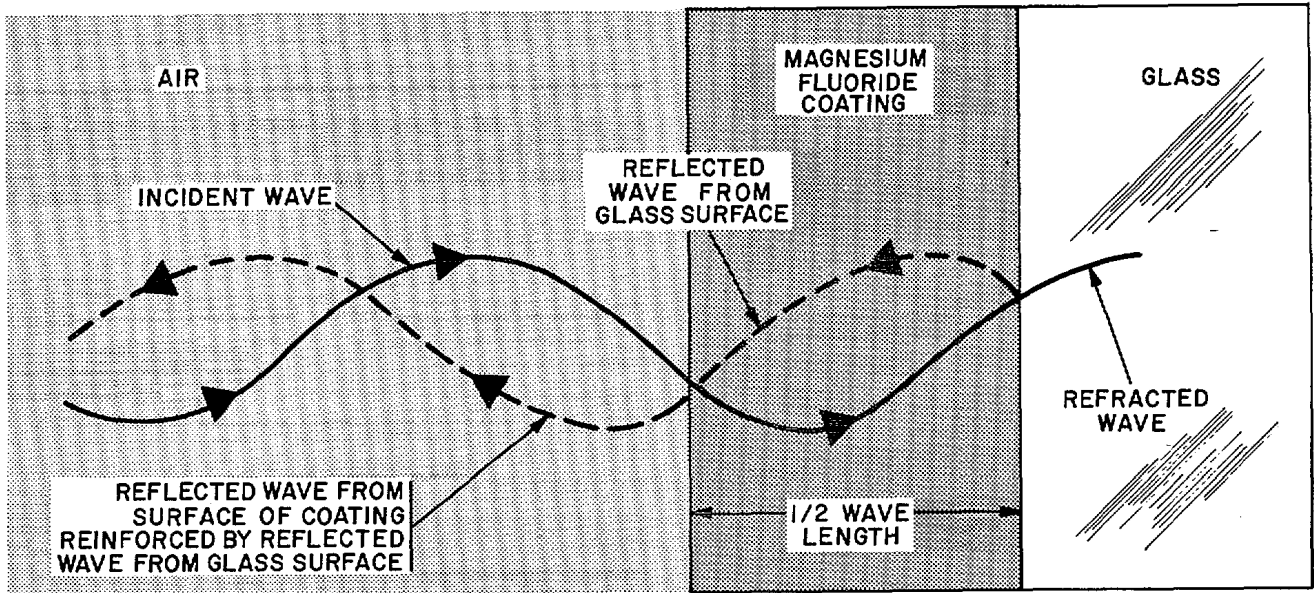

AR910122

Figure 4-32. Light ray striking coated surface (coating one-half wave length in thickness).

c. If, however, the film were only one-quarter of a wavelength in thickness, the reflected waves would follow paths which would cause them to interfere with each other and the reflected waves would cancel

each other (fig 4-33). The radiant energy, which is light, is not lost when the reflected waves are canceled; instead, this energy is contributed to the refracted light.

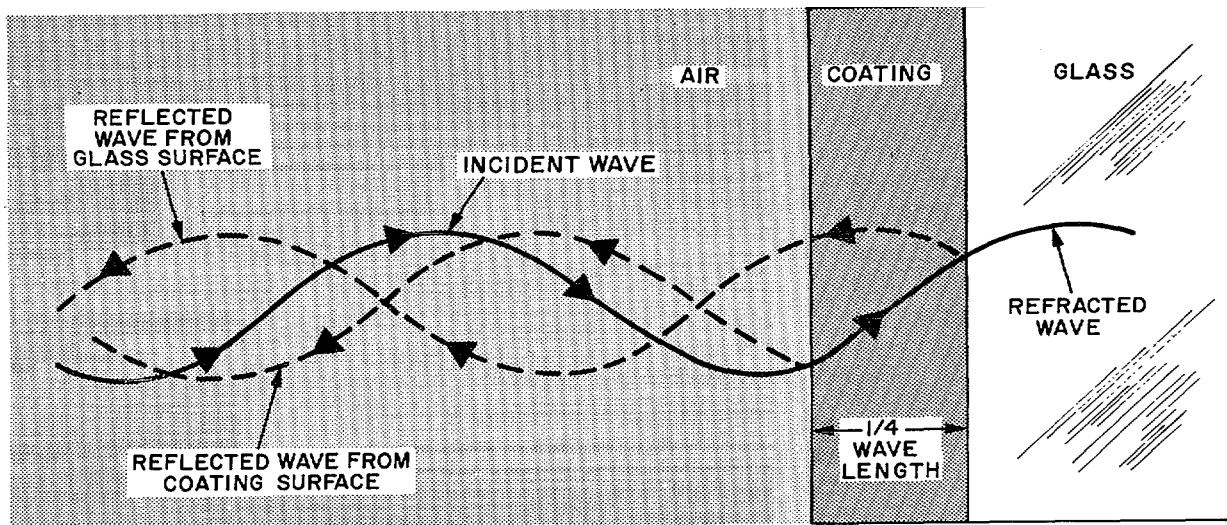

AR910123

Figure 4-33. Light ray striking coated surface (coating one-quarter wavelength in thickness).

d. Another way to understand the action of coated optics is to consider two incident light waves: ray 1 and next oncoming wave, ray 2. With a film of one-quarter wavelength in thickness, the time required for a wave in ray 1 (fig 4-34) to travel from the top of the film to the bottom and return results in a one-half wavelength lag relative to the reflected wave from the next oncoming wave, or to the coincident reflected wave in ray 2 at the

top surface so that the two are 180° out of phase. The vibrations of these two coincident reflected waves then are in opposite directions and cancel each other, the same as two matched teams in a tug of war, pulling with equal force, remain stationary. Because of the 180°

phase shift previously mentioned however, the oncoming wave in ray 2 coincident (at the air-to-film interface) with the wave from ray 1 (reflected from film-to-glass interface) will be in phase. Reinforced transmission of ray 2 will result.

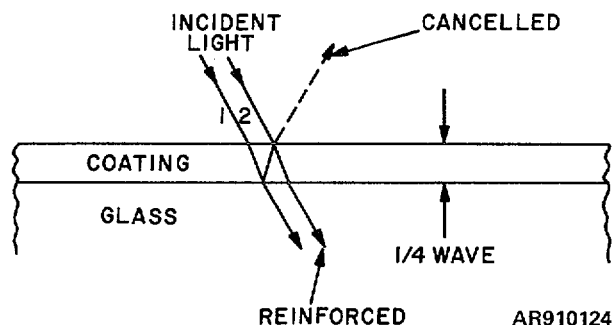

Figure 4-34. Low-reflectance coating.

e. Since the wavelength is different for each different color of light, one color must be selected to determine how thick the coating shall be. Green light, with a wavelength of 20 millionths of an inch, is the logical color to use since it is in the middle of the visible spectrum. This color is in the brightest region and contributes most to vision. The thickness of the coating, therefore, should be 1/4 of 20 millionths of an inch, or equal to 5 millionths of an inch and result in increased transmission of green light and adjacent colors (diminishing toward outer colors in spectrum). Reflection of the colors at the extreme ends of the spectrum (red and violet) is not eliminated completely. Therefore, light reflected from a coated optical element appears purplish, similar to a mixture of red and violet regardless of coating material used. Thus presence of coating is apparent to visual inspection. The common soap bubble or oil slick on water reflects iridescent colors because of the varying thickness of the film.

f. Another useful application of magnesium fluoride coatings is on front surface aluminized mirrors used in optical instruments. In this case, a film thickness of one-half wavelength causes reflected waves to reinforce each other (fig 4-32).

Such coatings also may be applied to front surface silvered mirrors. An aluminum or silver surface coated in this manner is no longer soft and easily scratched, but becomes harder and more durable and may be cleaned like other optical elements.

#### 4-15. Identification

a. Whether or not an instrument is fitted with coated optics can be detected readily by holding the instrument at an angle to a source of light and observing

the reflections from the eyepiece and objective end surfaces. If the optical elements in the instruments are coated, the reflection of light will have a distinctive purplish tinge. Under certain conditions, the faces of lenses may appear to have a dull film or patina.

b. An alternative method is to compare the illumination of the field of view of an instrument with the same model number of series known to have optical elements that are uncoated. The instrument with coated optics will have a much brighter field.

c. All fire-control instruments with coated optics bear a decalcomania transfer with the following wording: "This Instrument Has 'COATED OPTICS'. Clean Lenses Carefully."

d. The magnesium fluoride coating is referred to as hard coating. There are a few instruments in the field with elements coated with what is referred to as soft coating. The coating on these elements is not as durable as the hard coating. A simple test will distinguish a hard coating from a soft coating. With a soft rubber eraser, rub the coated element near the edge so as not to impair the usefulness of the element. About 20 strokes will remove a soft coating, but hard coating will not be affected.

#### 4-16. Serviceability.

a. Hard coating films on coated optics are tough and durable. They are insoluble in water, are not affected by oil and alcohol, and salt water will not harm them if cleaned off promptly. The coat will withstand temperature from -60 to +200° F. They are specified to withstand a rubbing of a 3/8-inch pad of dry cotton, exerting a force of 1 pound rubbed in any direction 50 times. However, due to the critical significance of the thickness of the coating the effectiveness of the coating may be completely destroyed by carelessness, ignorance, or rough treatment.

b. Scratches tend to lower the quality of the lens. Wearing down of the film due to repeated cleaning is not harmful to the element itself, but a reduction in thickness of the film much below one quarter of a wavelength of green light reduces its efficiency as a coated optical element. Partial or complete removal of the coating does not make the optical element useless but merely partly wholly takes away the benefit of the coating, leaving the element as if it had not been coated in the first place. It is important that remnants of a partly deteriorated coating should not be removed, since even a partially coated lens will be more effective than an uncoated one.

c. Coated optics slowly deteriorate under fingerprints, under prolonged action of atmospheric dust and moisture, and salt water. Instruments containing coated optics should be well sealed. Exceptional precautions must be taken to prevent sealing and cementing com-

pounds from getting on the coated surfaces of lenses. The removal of such compounds undoubtedly would result in injury to the coated surfaces.

d. Every precaution should be taken to prevent inexperienced personnel from misunderstanding the function of the coating and attempting to remove it.

### Section III. GENERAL CONSTRUCTION FEATURES

#### 4-17. Lens Cells, Separators, Lens Retaining Rings, and Adapters.

a. A *lens cell* (fig 4-35) is a tubular mounting or frame made of metal, plastic, or hard rubber which holds a lens or a number of lenses in the proper position within an optical instrument. The lens usually is secured into the cell by a lens retaining ring or by turning over a

thin edge of the cell (burnishing). A setscrew locks the retaining ring in position in the lens cell. When two or more lenses are mounted in a cell, the different elements are maintained at the proper distance from one another by spacers or separators. The cell mounting permits the entire assembly to be handled and mounted as a unit.

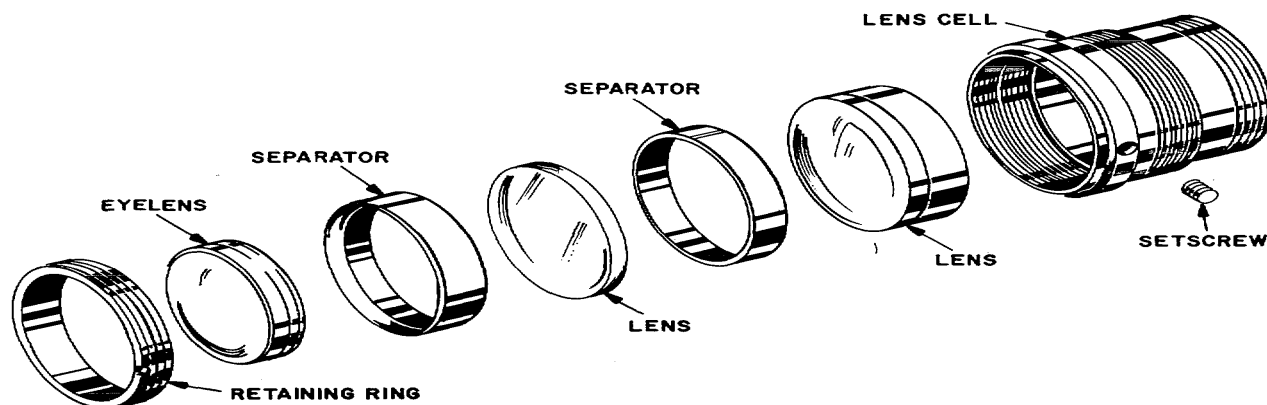

AR910125

Figure 4-35. Lens cell, separators, lenses, and retaining ring.

b. *Separators or spacers* are smooth or threaded tubular sections which separate or space the elements of a lens system in the proper relation with one another (fig 4-35). Adjoining faces are usually beveled to fit the faces of lenses snugly.

c. *Lens retaining rings* are generally threaded about their outer diameters and are screwed in over lenses to secure the lenses to their cells.

d. *Adapters* may be used to mount an element or part of smaller diameter into a part of the instrument body which is of larger diameter.

#### 4-18. Centering Devices.

a. Light always bends toward the thickest part of a

lens or prism. When the center of a lens is moved it can be made to cause the light to be bent in a different direction. In cases where extreme exactness is required, proper adjustment of the center of the objective is accomplished by mounting it in a pair of eccentric rings (fig 4-36). By rotating the inner ring about in the outer ring, or by rotating the outer ring in the lens cell, the axis of the objective may be moved to any point in a relatively large area. When properly positioned, the rings may be locked in position. Skill is required to set the rings in the proper manner.

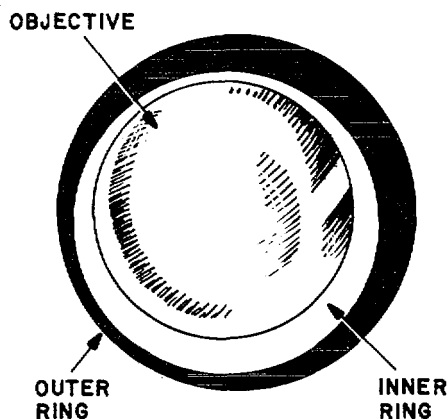

AR910126

Figure 4-36. Eccentric objective mounting.

b. Prisms were formerly often placed in mountings designed to hold them firmly and yet afford movement for exact adjustment. Screws bear upon two faces of the prism to lock it in place in such mountings. By letting out on one screw and taking up on the other, the prism may be positioned exactly. Extremely fine adjustments can be made. Care must be exercised in tightening screws to insure that prisms will not chip or crack from excessive pressure.

c. In modern instruments, mirrors and prisms are bonded to metal brackets or holders. Adjustment of the various components is accomplished by the screws bearing against the metal holder.

**4-19. Eyeshields.** *Eyeshields or eyeguards* are fitted to fire-control instruments to maintain proper eye distance and to protect the eyes of the observer from stray light, wind, and injury due to the shock of gun fire or similar disturbances. Eyeshields are made of rubber, plastic, and metal but only those made of soft rubber can most effectively meet all of these requirements.

**4-20. Sunshades and Objective Caps.**

a. *Sunshades* are tubular sections of metal, usually with the lower portion cut away, which are fitted into slots around the objective cells of many instruments to protect against rain and the direct rays of the sun (fig 4-37). They not only reduce glare which would be

caused by sunlight striking the outer face of the objective, but they protect from extreme heat the thermosetting cement used to cement the elements of the objective.

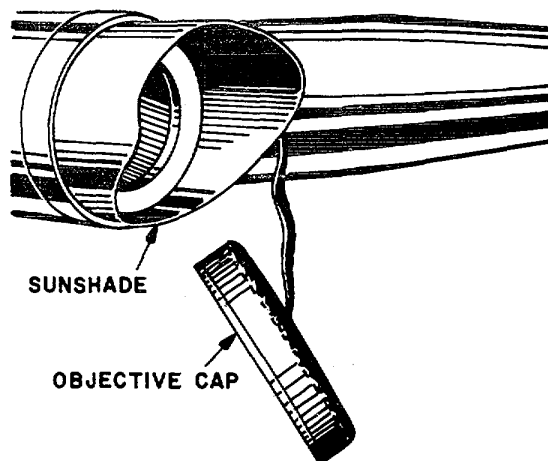

AR910127

Figure 4-37. Sunshade and objective cap.

b. *Objective caps* (fig 4-38) are leather covers which are fitted over the sunshade or objective end of the instrument to protect the objective when the instrument is not in use. The caps are usually attached to the instrument by strips of leather to prevent loss.

**4-21. Focusing Devices.** The distance between the reticle and the eyepiece must be adjusted to the observer's eye so that the reticle and image of the object will be sharply defined and to eliminate eye fatigue. To provide this adjustment, the two or more lenses of the eyepiece are mounted in a single tube or lens cell and its distance from the reticle (and the focal plane of the objective) can be adjusted by a rack and pinion, by a simple draw tube, or by rotating the entire eyepiece when adjusting the diopter scale (fig 4-38) causing it to screw in or out. This is referred to as the diopter movement (para 5-14). The knurled ring of the "screw out" adjustment type is provided with a scale reading in diopters by which this adjustment can be made directly if the correction required by the eye is known.



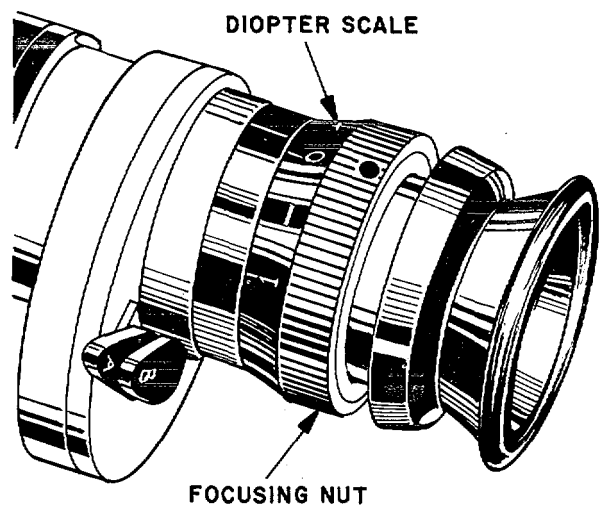

AR910128

Figure 4-38. Diopter scale.

#### 4-22. Optical Bars.

a. In a range finder, the angles of the lines of sight from both ends of the instrument are employed to determine the range. Heat and cold cause unequal expansion and contraction of metal parts disturbing the angular alinement of elements mounted on or in them. The angles determined by the range finders are so small that an excessive error could be introduced by the deviation caused by any misalignment if special measures were not taken to keep the optical systems stable and in perfect alinement.

b. One of these measures consist of mounting the most sensitive parts of the instrument in a metal tube known as the optical bar. The optical bar is made of specially composed metal with a low coefficient of expansion. It is perfectly balanced and is supported by the inner or main tube of the instrument in such a manner that the outer tube may expand or contract without affecting the alinement of the inner tube. In addition, the instrument is insulated to reduce temperature changes to a minimum.

## CHAPTER 5

## ELEMENTARY PRINCIPLES OF TELESCOPES

## Section I. INTRODUCTION

**5-1. History of Optical Instruments.** The earliest record of the use of a lens as a magnifier is estimated to have been in the eleventh century and attributed to an Arabian philosopher names Alhazen. In the thirteenth century, spectacles were devised based on work done both by Roger Bacon and by a Florentine monk named di Spina. But as the seventeenth century opened, nobody had as yet devised a telescope. Quite by accident a Dutch optician, Jan Lippershey, made the discovery in 1608. His telescope used a 1 1/2-inch diameter positive (convergent) objective lens of 18-inch focal length and a negative (divergent) eyelens of 2-inch focal length. Lippershey was refused a patent by the Dutch government because of confusing counterclaims from supposed competitors but in the spring of 1609 the Italian scientist Galileo carried on the work. He duplicated the original using an instrument of 8 power. Not satisfied, he made another instrument 37 inches long of 8 power and still another 49 inches long with a very short focus eyepiece giving 33 power. His famous astronomical discoveries were made with the latter instrument and the optical system he used is still known as the Galilean telescope. A refracting astronomical telescope of modern design, using a positive objective lens, and a positive eyelens, was designed by the German astronomer Kepler in 1610 and some 30 years later a Scottish mathematician named Gregory designed the first reflecting telescope which is the basis of many modern astronomical instruments. In the latter part of the nineteenth century, buffalo hunters on our western plains used telescopic sights on their rifles. The telescopic sight, the most accurate of all sighting devices, is too easily damaged to be an item of issue with the infantry rifle except those weapons used by snipers. It is used, however, on all types of field pieces and Naval rifles. The remainder of this text is devoted mainly to a study of the principles involved in such applications of telescope as telescopic sights and observation instruments.

**5-2. Simple Magnifier.** The simple magnifier consists of a positive (converging) lens at the first focal plane of the eye, although this positioning is not too important. If the object being viewed is at or within the focal point of the lens, a virtual, erect, and enlarged image is seen by

the eye. It should be remembered that rays from a distant point are, for all practical purposes, parallel and that the eye can focus or form an image with these parallel rays without accommodations. If the object is at the focus (focal point) of the lens, it is seen by the eye without accommodation as the emergent rays are then parallel (as if originating at a distant object) as illustrated in figure 5-1. If the object is within the focal length of the lens, accommodation by the eye is necessary as the emergent rays no longer are parallel but are diverging, as if from a near object, as in figure 5-2.

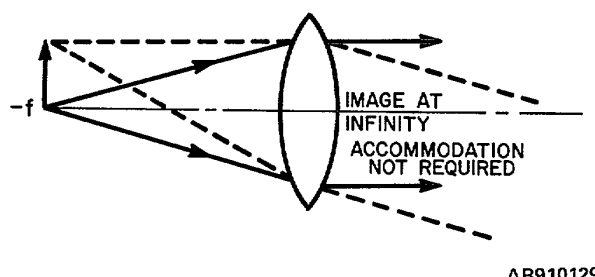

AR910129

Figure 5-1. Simple magnifier-object at principal focus

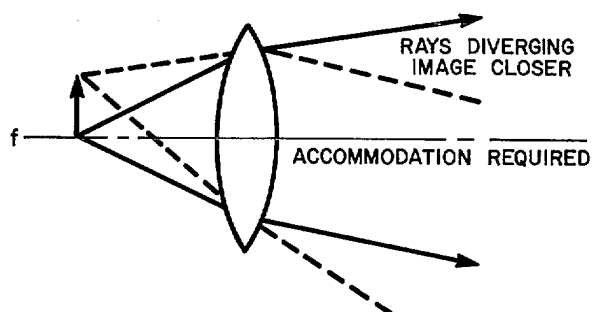

AR910130

Figure 5-2. Simple magnifier-object within focal length

**5-3. Compound Microscope.** The real purpose of the microscope is to aid the human eye, essentially a long-range high-acuity instrument, to be useful at short dis-

tances. If it is recalled that apparent size equals actual size divided by distance to object, it should be apparent that the closer an object is to the eye the larger will be its image. The microscope uses an objective lens of extremely short focal length ( $f_o$ ) which forms a real, enlarged, and inverted image of an object placed just behind its principal focus. To view this image, a positive eyepiece of short focal length ( $f_e$ ) is used as a magnifier. If the real image is at the first principal focus

of the eyelens, the image is seen at infinity and no accommodation is required. Final image may be formed at any distance from the eyelens exceeding the shortest distance of distinct vision (about 10 inches). In this case, the image formed by the objective lens must be within the principal focus of the eyepiece as in figure 5-3. Magnification in a microscope depends on the focal lengths of the objective and the eyepiece and the distance between them.

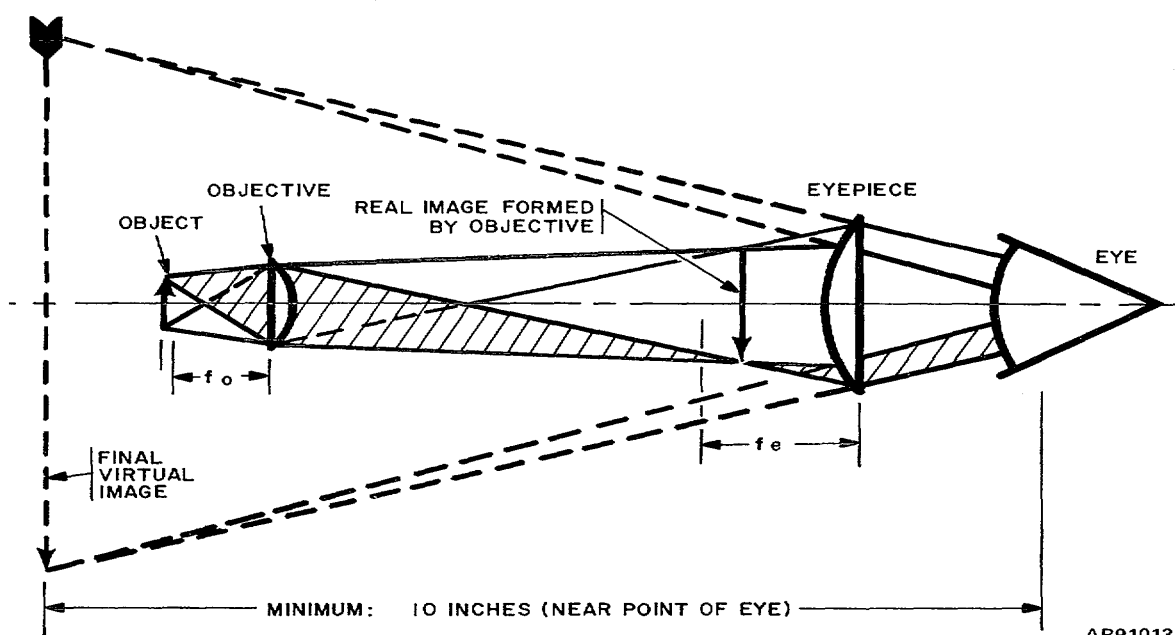

AR910131

Figure 5-3. Simple compound microscope

**5-4. Telescopes.** Most persons think of telescopes as magnifiers but they may be designed to provide the eye with an image the same apparent size as the object or they may provide the eye with a smaller image which is an example of reduction. The primary purpose of the telescope is to improve vision of distant objects. In its simplest form, it consists of two parts; a lens or mirror

called either the objective or objective glass (if a mirror) which usually forms a real image of the field or area which the telescope can "see," and an eyelens or eyepiece used to view this image. This general description is exactly the same for the microscope, except that in the microscope the first image is actually larger than the object while in the telescope the first image is smaller than the object.

## Section II. ASTRONOMICAL TELESCOPES

**5-5. Refracting Telescopes.** Refracting astronomical telescopes use lenses to form images through refraction. A positive lens alone will form only real images of distant objects. Such real images in space

cannot be brought to focus by the eye (fig 5-4). The eye must be fed either by parallel rays or rays only slightly diverging as if from an object no closer than the near point of the

eye. However, if another positive lens is placed between such an image and the eye, and the real image lies at the first focal point of this eyelens, the eye can see without accommodation of a virtual image of the object seen by the objective lens. This is the Keplerian system (fig 5-5). Such an arrangement is a telescope of the simplest form and is illustrated in figure 5-6 with the virtual image moved in to the near point of the eye. This system generally is limited to astronomical observation because the image is inverted. The Army uses this system only to adjust other types of telescopes and when it is so used, calls it a collimating telescope.

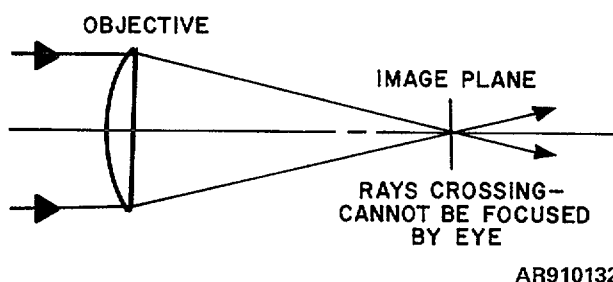

Figure 5-4. Objective lens.

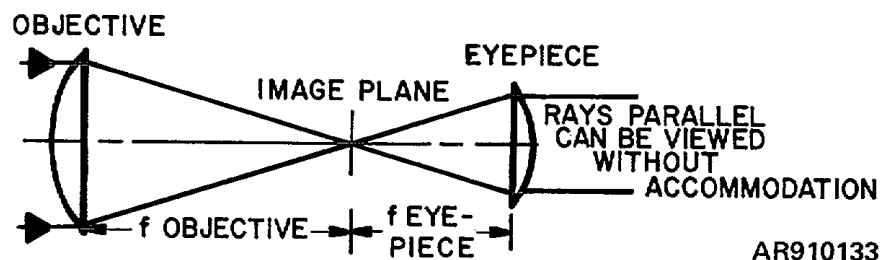

Figure 5-5. Keplerian system

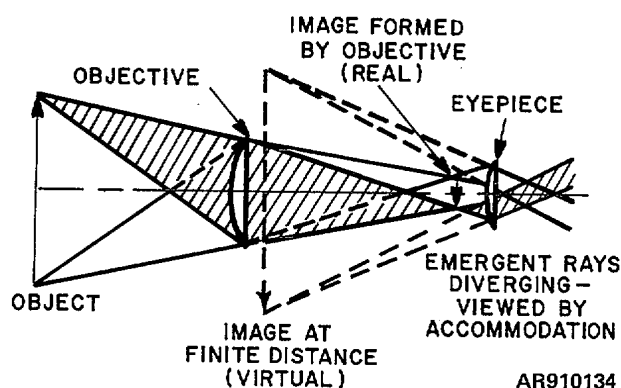

Figure 5-6. Refracting astronomical telescope

**5-6. Reflecting Telescopes.**

*a. Types of Spherical Mirrors.*

(1) *Convex.* In this case, the mirror surface is on the outside of a spherical surface, the center of curvature of which lies on the side opposite the incident light. This type of spherical mirror produces small virtual image only. It is frequently used on trucks as a rearview mirror.

(2) *Concave.* In this type, the light is incident on the same side as the center of curvature (C) of the sphere. The focal point (f) is located halfway between center of curvature and reflecting surface (fig 5-7). The concave mirror forms virtual and enlarged images of objects within its focal length which is one-half the radius of curvature. Some of the uses to which it is put are headlamp reflectors, searchlight reflectors, and objective glasses in astronomical telescopes.

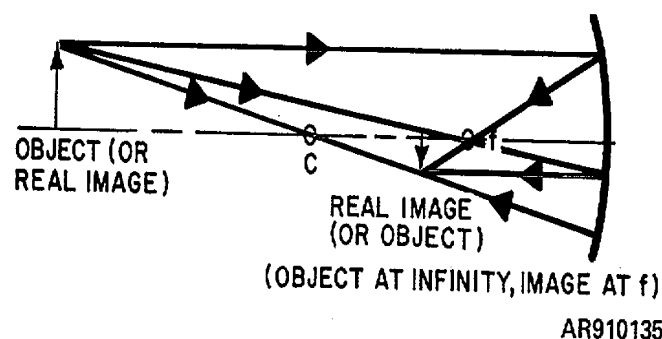

Figure 5-7. Concave mirror

(a) An object beyond center of curvature forms a real image between center of curvature and focal point. This image is smaller than the object and inverted and reverted.

(b) When the object is between the center of curvature and the focal point, the image is formed beyond the center of curvature and is real, enlarged, and inverted and reverted.

b. *Reflecting Telescope.* This telescope, diagramed in figure 5-8, utilizes a concave mirror of long focal length (instead of an objective lens) to form the real image. This is viewed as a virtual image through an eyepiece which magnified it or is photographed by a camera attachment. The Mt. Palomar telescope, for example, has a 200-inch diameter mirror of long focal length, great light-gathering ability, and great resolving power. (For resolving power see para 5-30).

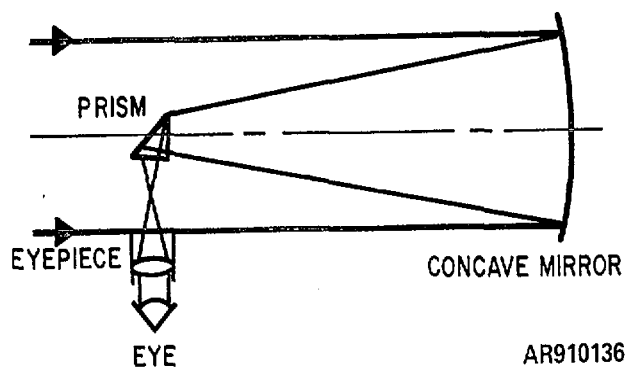

Figure 5-8. Reflecting astronomical telescope.

**5-7. Magnification of Telescopes.**

a. Computation of power in an astronomical telescope is done by dividing the focal length of the objective by the focal length of the eyepiece. This is true only when the virtual image is at infinity or when emergent rays from point object are parallel. If the image is moved to the near point of the eye (10 inches), it increases slightly in size.

b. This equation cannot be applied to all terrestrial systems using lens erecting systems since such erecting systems can, and usually do, contribute to the power. It can be applied to any terrestrial system using a prism erecting system.

**Section III. TERRESTRIAL TELESCOPES**

**5-8. General.** This instrument gets its name from the Latin term "terra" which means earth and is basically useful for looking at objects as they actually appear to us on earth. Any astronomical telescope can be converted into a terrestrial telescope by inserting an erecting system, either lens or prism, between the objective and

the eyepiece to erect the image as in figure 5-9. A prism erecting system is placed between the objective and its focal point, but a lens erecting system requires repositioning of objective and eyepiece so that erectors are between objective focal point and first principal focus of eyepiece.

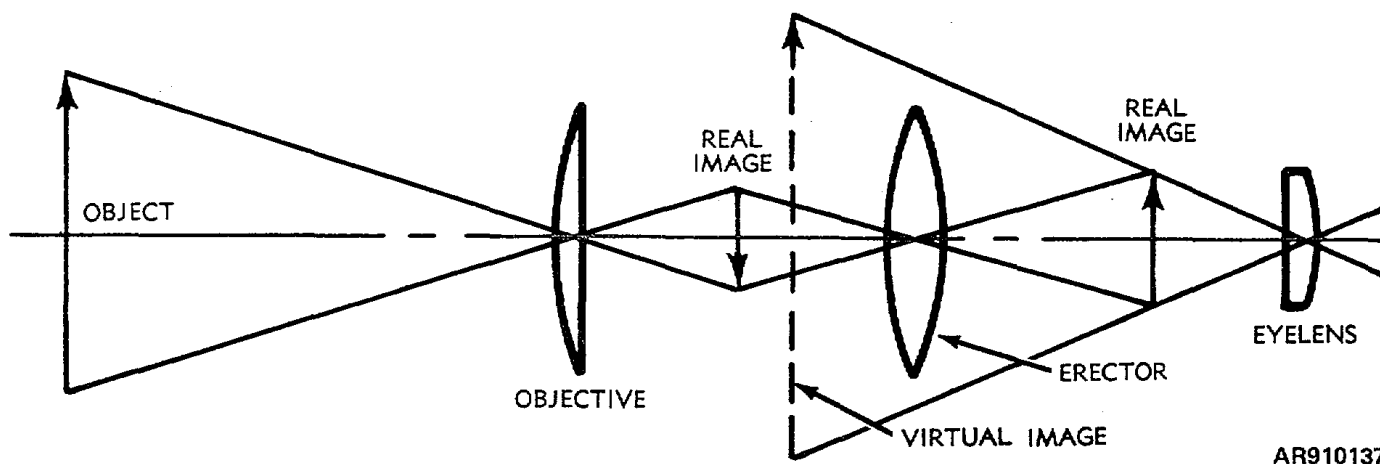
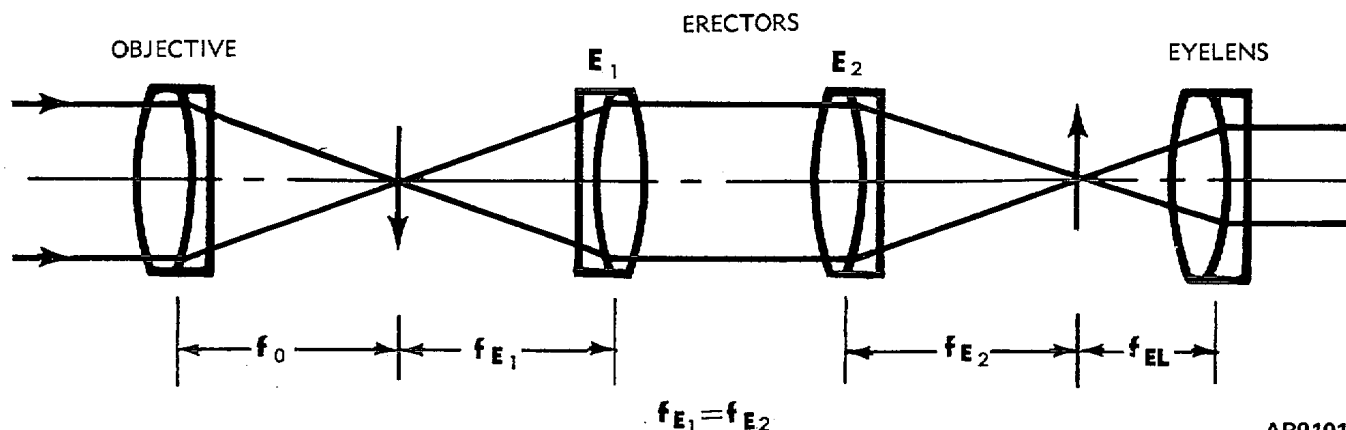

Figure 5-9. Terrestrial telescope—simple form.

**5-9. Lens Erecting Systems.**

a. *Location.* A lens erecting system is placed between the focal plane of the objective and the front focal plane of the eyepiece. In practice, to minimize aberrations, two or more lenses usually comprises a lens

erecting system. The first lens may be placed one focal length behind the image formed by the objective and the second spaced a distance equal to the focal length of either to minimize spherical aberrations (fig 5-10).



AR910138

Figure 5-10. Symmetrical erectors.

b. *Symmetrical.* A true symmetrical erecting system is composed of symmetrical lenses so positioned that the object (real image formed by the objective) and image distances are symmetrical or equal (fig 5-10). In other words, the image formed by the objective is at the focal point of the front erector and the rays between the two erectors are parallel. Therefore, spacing between erectors is not critical and does not affect magnification as the magnification in such a system (always-1) indicates an inverted image of same size as object regardless of lens separation.

c. *Variable Magnification.* Variable magnification erecting systems used in variable power telescopes may provide (in the high-power position) from two to three times the power produced in the low-power position depending on the design. In the simplest lens erecting system (a single lens), magnification can be shown to be a function of object distance and image distance (A and B, fig 5-11, and para 2-24e). The same is true if a combination of lenses (usually two) is used.

separation between the elements in the erecting system (A, B, and C fig 5-12).

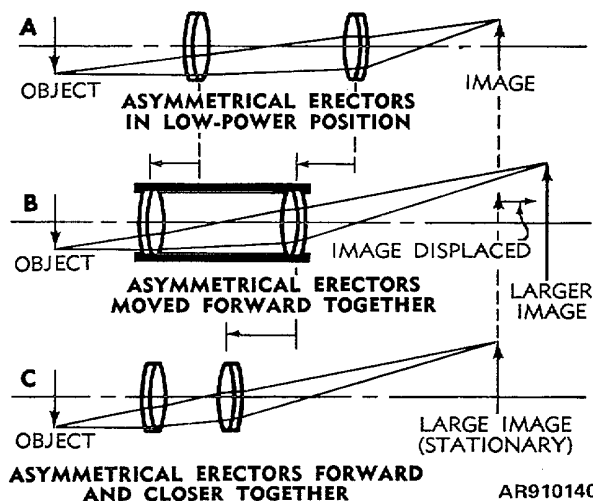

AR910140

Figure 5-12. Asymmetrical erectors.

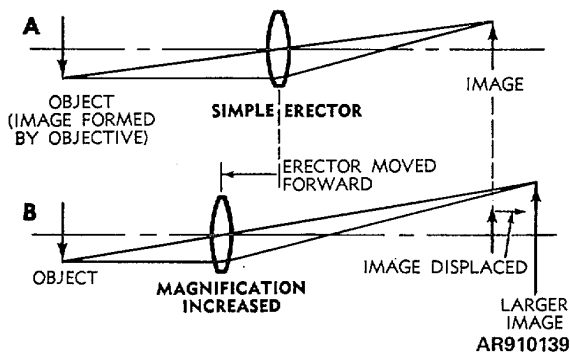

AR910139

Figure 5-11. Simple erector.

(1) Magnification of an erecting system composed of a combination of asymmetrical lenses (lenses of different focal lengths) can be varied either by varying the distance of the erecting system from its object (image formed by objective) or by varying the

(2) When magnification is increased by shifting erectors forward, the image position shifts toward the eyepiece as in B, fig 5-12. A change in distance then, between the asymmetrical elements in this forward position, further affects magnification and image distance. A decrease in the distance between the elements, i.e., moving the second lens nearer the first, lessens the increase in magnification slightly but more important decreases the shift in the resulting image position as in C, figure 5-12. By design, the image position can be the same for any of the possible magnifications. In this case, the separation between erector elements is always such that the image position remains fixed for any magnification and the eyepiece can be fixed (C, fig 5-12).

(3) If magnification is increased, either by shifting the erector system forward as a complete

unit or by moving only the rear erector element forward, the image formed by the erectors will move back. In this case, it is necessary to move the eyepiece back a distance equal to the image shift to keep the image in focus (B, fig 5-12).

**5-10. Prism Erecting Systems.** A prism erecting system (para 4-7d) may be used in a terrestrial telescope instead of a lens erecting system. In prism, offset, and elbow telescopes, it is placed between the objective and its focal plane. Either all or part of the prism erecting system, however, may be outside (in front of) the telescope system. In the BC periscope, the prism in the head is outside the periscope system but still a part of the prism erecting system. The prism in the head, together with the prism system in the elbow below, comprises a Porro prism erecting system. All observing and sighting telescopes used by the Army employ an erecting system.

**5-11. Galilean Telescope.**

*a. Basic Principles.* The system employed in the Galilean telescope is based on two major principles.

(1) It makes use of a negative eyelens positioned a distance equal to its focal length ( $f_e$ ) in front of the objective focal point (figs 5-13 and 5-14).

This negative eyelens is placed so that rays from the objective meet it before forming the real image, which does not exist, and is called the virtual object. Rays approaching this virtual object will be bent outward and made to diverge as if from the enlarged virtual image (fig 5-13). This renders converging rays from the objective parallel before they have converged to form a real image; therefore, no real image exists in this system. The real image, which would be formed by the objective if the eyelens weren't there, becomes the virtual object for the eyepiece and lies at the first principal focus of the eyelens. In this case, the virtual image viewed through the negative eyelens will be at infinity and can be viewed by the eye without accommodation. This is the zero diopter setting (fig 5-14) for this instrument, meaning that all rays from any point source emerge from the eyepiece parallel. If the eyelens is moved in or out, the emergent rays either will converge or diverge so that the instrument cap be adjusted for farsighted or nearsighted eyes or for distance. The image viewed through the eyepiece is erect because the emergent rays are bent further away from the axis instead of recrossing it as in a Keplerian or astronomical system employing a positive eyelens. Compare figure 5-13 with figure 5-6.

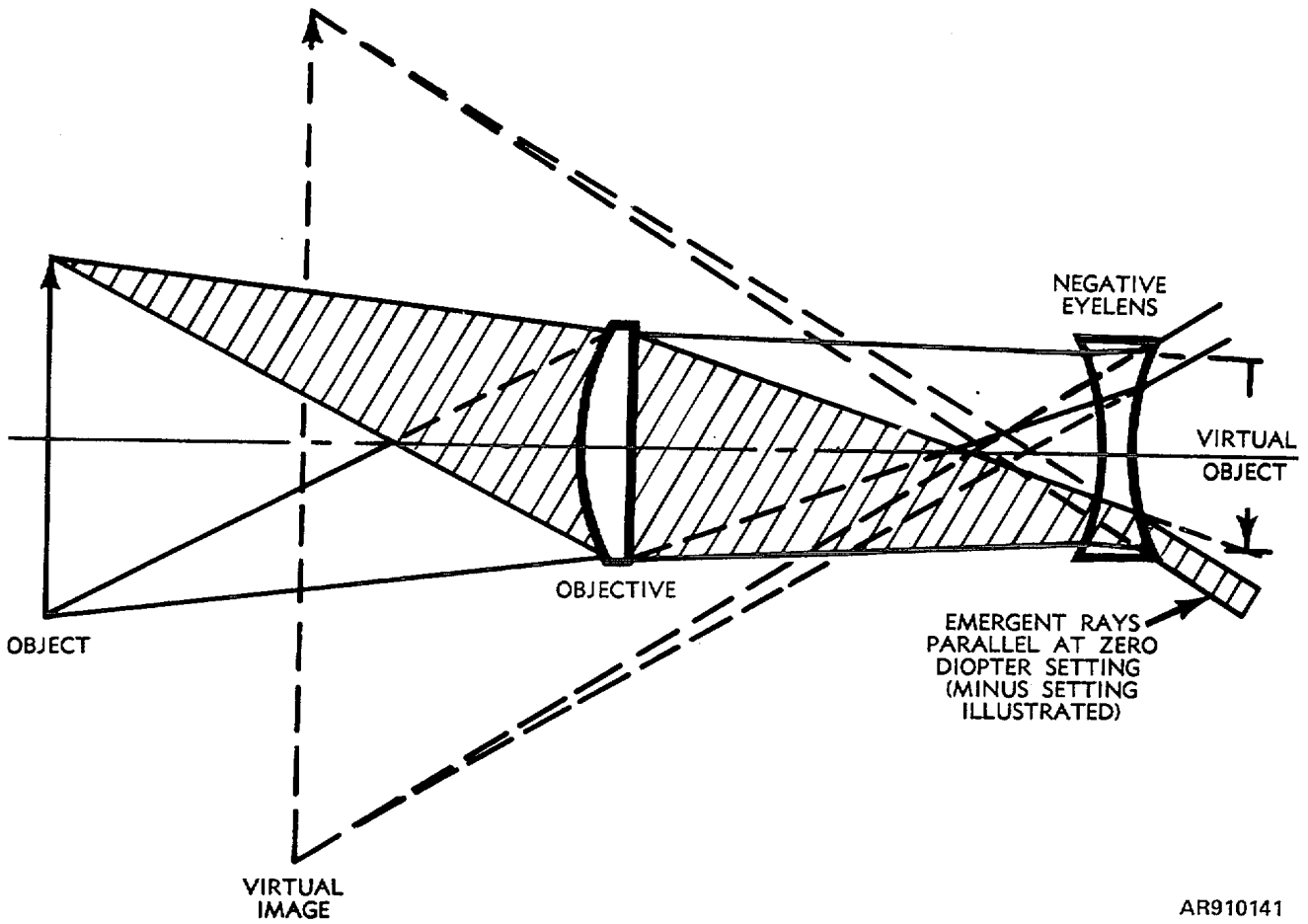
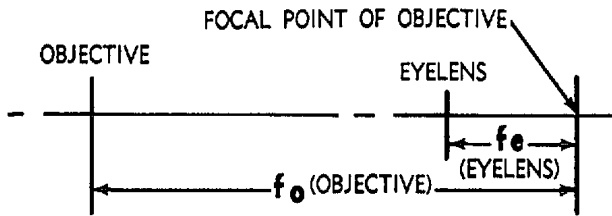

Figure 5-13. Galilean system.

AR910141

(2) This is the only telescopic system in which the diameter of the objective controls the field of view (width of visible observed area), as the objective is both field stop and entrance window (fig 5-15). This system is, therefore, limited to small fields and low power and usually is designed for 2 or 3 power.



AR910142

Figure 5-14. Relations of elements in Galilean telescope (zero diopter setting)



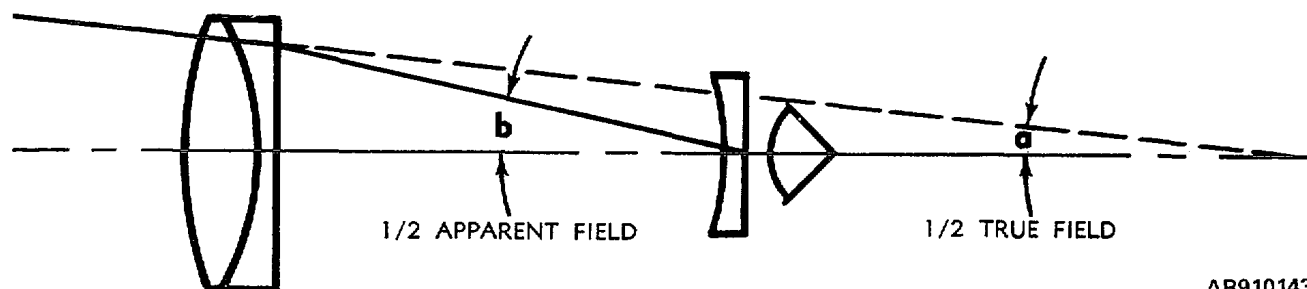

AR910143

Figure 5-15. Objective diameter limits field in Galilean system

*b. Uses.* This system is quite inexpensive because of its simplicity and is used in field glasses. It is used in opera glasses because of its very short length and light weight. Note that it provides an erect image without lens or prismatic erectors in a system shorter than a modern astronomical system of equal power. It

is used frequently as a reduction view finder on cameras by reversing it with the positive element used as the eyelens and the negative as the objective. Because of its low power limited field, and lack of real image plane, it has no application in military instruments in this country.

#### Section IV. FUNCTIONS OF COLLECTIVE LENSES AND EYEPIECES

##### 5-12. Functions of Collective or Field Lenses.

*a. Primary Functions.* This element (usually plano-convex) may be placed in a system with the plano side coincident with the image plane (focal plane) of the objective. If the principal plane of this lens lies in the image plane of the objective, this lens *does not alter the power* of the instrument but reduces the power if placed closer to objective (fig 5-16). The collective lens provides *balanced illumination* of the entire field. Rim

rays would miss the erectors without it and leave the outer portions of the field with less illumination than the central portion. The clear aperture required in the lenses in the erecting system is reduced so that smaller lenses can be used or the collective lens can be considered to increase the field, if the erectors are of sufficient size and the eyepiece has sufficient apparent field.

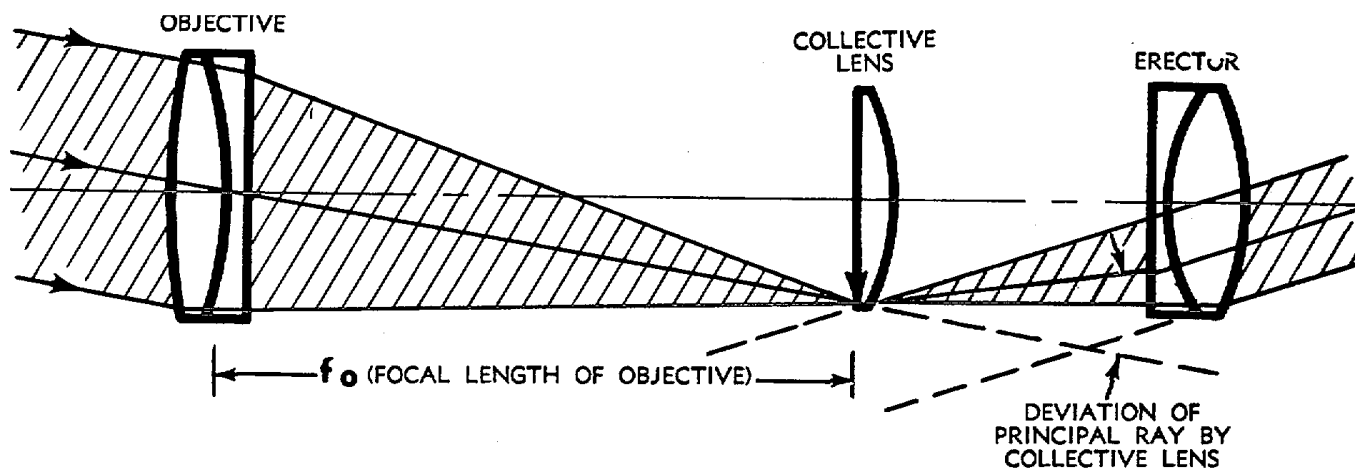

AR910144

Figure 5-16. Function of collective lens.

b. *Secondary Functions.* This lens also shortens the eye relief (distance from eyelens to eye) of the instrument by shifting the plane of the exit pupil (in which the eye must be located to view the full field) closer to the instrument. It is not used, therefore, in rifle scopes or gunsights where long eye relief is essential to avoid injury from the recoil.

**5-13. Functions of Eyepiece or Ocular.**

a. *General.* An eyepiece in its simplest form may consist of a single lens (simple magnifier) which presents to the eye an enlarged virtual image of the real image formed either by the objective or the erectors as illustrated in figure 5-17. The usual apparent field provided by an eyepiece is 40 to 50°. A wide angle eyepiece is one fully corrected to the edges and of sufficient aperture so that in a system of given eye relief a wide field of up to 75° may be provided. Because magnification is angular, this apparent field limits the true field of the instrument for any certain power. For example, a 4-power instrument with an eyepiece providing a 40° apparent field will have a true field of 10°. This will be discussed fully in paragraphs 5-21 through 5-31.

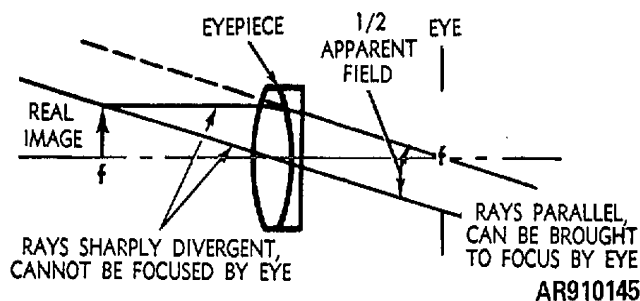

AR910145

Figure 5-17. Function of eyepiece.

b. *Function of Elements.* In a simple eyepiece using two lenses, an eyelens next to the eye provides all or most of the magnification depending on the location of the field lens relative to the real image. The field lens (fig 5-18), if in the image plane, has no effect on magnification but acts as a collective lens providing balanced illumination of the field. Without the field lens principal rays from the edge of the field would miss the eyelens and leave the edge of the field dark. With the field lens in the image plane, however, any dust on its surface lying in the image plane will be in sharp focus. For this reason, unless there is an etched reticle on this surface, the field lens usually is displaced slightly from the image plane thus contributing to the magnification. Another reason for not placing the field lens in the focal plane is that this is the position normally occupied by the reticle in those instruments employing reticles with the reticle pattern etched on glass or a

**NOTE**

The power of an eyepiece is inversely related to its focal length; i.e., high-power eyepiece is one of short focal length. It is thus possible to replace an eyepiece with one of shorter focal length and increase the power of the instrument.

crosshair mounted on a reticle holder ring. If the eyelens and the field lens are of the same power (focal length) and the field lens lies in both the image plane and the first focal plane of the eyelens, the image will be viewed at infinity (without requiring accommodation by the eye).

**NOTE**

A field lens in the image plane shortens eye relief by shifting the plane of the exit pupil without affecting its size (para 5-27b). The field lens also increases the apparent field of the eyepiece.

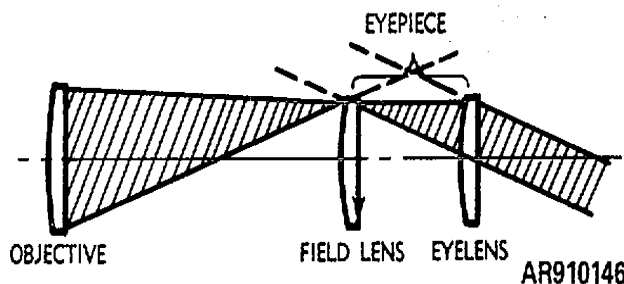

Figure 5-18. Function of field lens in eyepiece.

**Section V. ADJUSTMENTS**

**5-14. Diopter Movement.**

a. *Zero Setting (Normal).* In a well-adjusted instrument the beams of light from each point in a distant field or target will emerge from the eyepiece (of focal length  $f_e$ ) as a beam of parallel rays. This is a *zero diopter setting* (para 10-1), as diagramed in figure 5-19, and will feed the eye with the same parallel light as that received from distant points by the unaided eye. The normal or emmetropic eye, therefore, can view the field through the instrument without accommodation.

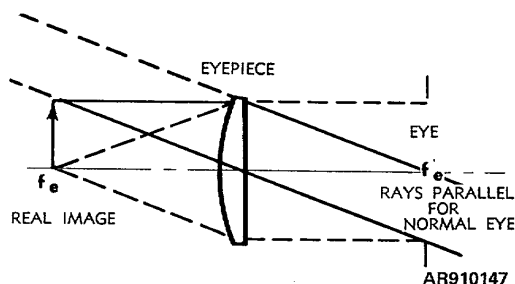

Figure 5-19. Zero diopter setting.

b. *Minus Setting (Shortsighted).* The shortsighted or myopic eye will form an image in front of the retina. Movement of the eyepiece toward the reticle and the real image under observation, will cause emergent rays from the eyepiece to *diverge* and correct for the deficiency of the eye. This is a *minus diopter setting* and is diagramed in figure 5-20.

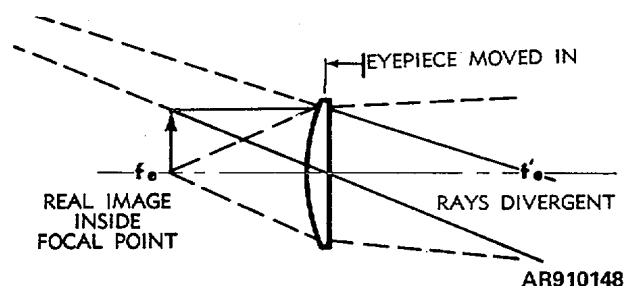

Figure 5-20. Minus setting for shortsighted eye

c. *Plus Setting (Farsighted).* Farsightedness or hypermetropia results in image formation in back of the retina. Movement of the eyepiece away from the reticle and the real image under observation, will cause rays emerging from the eyepiece to *converge* so that the farsighted eye can focus the image clearly. This is a *plus diopter setting* and is illustrated in figure 5-21.

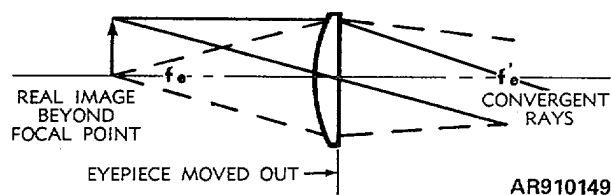

Figure 5-21. Plus setting for farsighted eye.

d. *Low-powered Instruments.* If the instrument is less than 4x, the eyepiece can be fixed focus for satisfactory use. This means adjusting the

eyepiece to a single focus setting at -0.75 to -1.0 diopter. A single focus setting will be satisfactory to any observer whose eye correction is not too great. In a low-power instrument, the objective is short focal length; therefore, the image plane shift is small when target distance changes unless the target is moved very close.

*e. High-Powered Instruments.* In high-power instruments (more than 4x) the diopter movement is useful because the eye relief frequently is too short (excepting in rifle scopes and gunsights) to permit view of full field while wearing spectacles. If the user's defective sight is not caused by astigmatism (is either farsighted or nearsighted) and the correction, required is within the range of the diopter movement, the diopter adjustment permits adjustment of the eyepiece to correct for his defective vision. This eliminates the necessity for spectacles while using the instrument. In a high-power instrument not having a reticle, the diopter movement permits focusing the eyepiece on the different image planes, resulting when the instrument is used at all ranges, thus focusing the instrument for the different ranges. An example of this is the observation telescope which can be used from approximately 50 feet to infinity.

*f. Diopter Scale.* The diopter scale on an eyepiece is calibrated in units indicating the movement of the eyepiece necessary to effect a change of 1 diopter in the emergent light. For example, at plus 1 the angular convergence is the same as with a 1-power lens (focal length of 1 meter) and the rays will focus or cross at 1 meter behind the eyepiece. At minus 1 the angular divergence is such that the rays, if extended back into the instrument, would cross at 1 meter forward of the eyepiece.

**5-15. Diptometer.** The diptometer (fig 5-22) is a precision instrument useful in determining accurately the diopter setting of another instrument. It is placed between the eye and the instrument to be checked. The focusing sleeve of the diptometer is then adjusted until the field is in sharp focus. The diopter setting of the instrument being checked is then read from the focusing sleeve (usually calibrated in 0.1 diopter) of the diptometer. Set at zero diopter the diptometer can be used to check the accuracy of the zero diopter setting in the collimating telescope itself which is commonly

available for checking zero diopter setting.

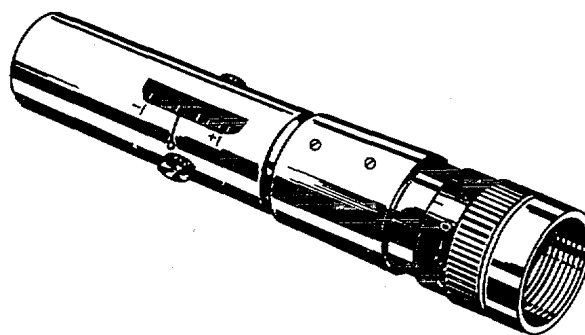

AR910150

Figure 5-22. Diptometer

### 5-16. Collimation.

*a. Definition.* Collimation is the alinement of the optical and mechanical axes of an instrument and necessitates a reticle in the collimating telescope so it can be used as a telescopic sight. (for reticles, see para 5-19). Alinement can be obtained by sighting through a fixed collimating telescope and the instrument to be collimated, and adjusting accordingly.

*b. Lens Decentration.* Lens decentration is utilized frequently in collimating optical systems, especially binocular instruments, which usually employ objectives mounted in eccentric rings (para 4-18) to permit movement in any direction across the axis. If a lens is decentered (moved across the axis of the system) it will cause an image shift in the same direction. The optical center seldom coincides with the exact geometrical center of a lens so that an image shift frequently will result from revolving a lens in its cell. In fact, disturbing any lens in a collimated system will necessitate collimation of the system again as any lens which fits freely enough to facilitate removal will almost surely not go back in its exact position.

*c. Prismatic.* If prisms are employed in a system, collimation also can be affected either by sliding prism parallel to the plane of reflection (causing an image shift in same direction) or by tipping prism and plane of reflection (shifting image in same direction).

## Section VI. FUNCTIONS OF TELESCOPIC SIGHTS

**5-17. Definition.** Terrestrial telescopes having a reticle in a focal plane in the optical system are commonly known as telescopic sights or military telescopes. Such a reticle can be placed in an astronomical telescope, as in the collimating telescope, but a telescopic sight is universally considered to be an instrument having an erecting system.

**5-18. Advantages.** A telescopic sight is advantageous in that it permits the viewing of reticle and target in the same optical plane and does not require precise alinement of the eye with respect to the line of sight. Alinement of the eye need be only within the exit pupil diameter. In comparison, open rifle sights require the eye to attempt an actual impossibility; the focusing simultaneously on rear sight, front sight, and target. The eye, furthermore, must be in perfect alinement with all three.

**5-19. Functions of Reticles.**

*a. Application.* Reticles (para 4-9) are used in fire-control instruments for superimposing markings or a predetermined pattern of range and deflection graduations on a target. A reticle in its simplest form is a post or picket, or it may consist of two intersecting lines; then the line of sight through their intersection will be in the center of the field of view. It represents the axis of the bore of the weapon when adjusted for short range firing or is fixed at a definite angle to the bore of the weapon for long range firing. A reticle is used as a reference point for sighting or aiming, or it may be

designed to measure angular distance between two points (stadia lines in a transit or grid lines in a military sight). As it is in the same focal plane as a real image, it appears *superimposed* on the target and can be viewed by the eye with the *same accommodation* required for viewing the target or field.

*b. Location.* In an optical system employing a lens erecting system, there are two possible reticle locations (fig 5-23). It may be placed either in the image plane of the objective or at the focal point of the eyepiece (image plane of erectors). If the erecting system increases the magnification and the reticle is in the image plane of the objective, the reticle lines will appear wider on the target than if placed at the focal point of the eyepiece. For this reason, the reticle in a low-power rifle scope usually is placed in front of the erectors and in high-power target-type rifle scopes, it is at the focal point of the eyepiece. With a lens erecting system, the reticle may be placed at the front or rear of the erecting system, or reticles may be placed at both points, and their patterns are then observed superimposed upon each other. The preferable position with this type of erecting system is in front of the system as the objective and reticle then form a unit and any shift of the erecting system does not disturb the alinement of these elements. With a prism erecting system, the reticle usually is placed in back of the erecting system.

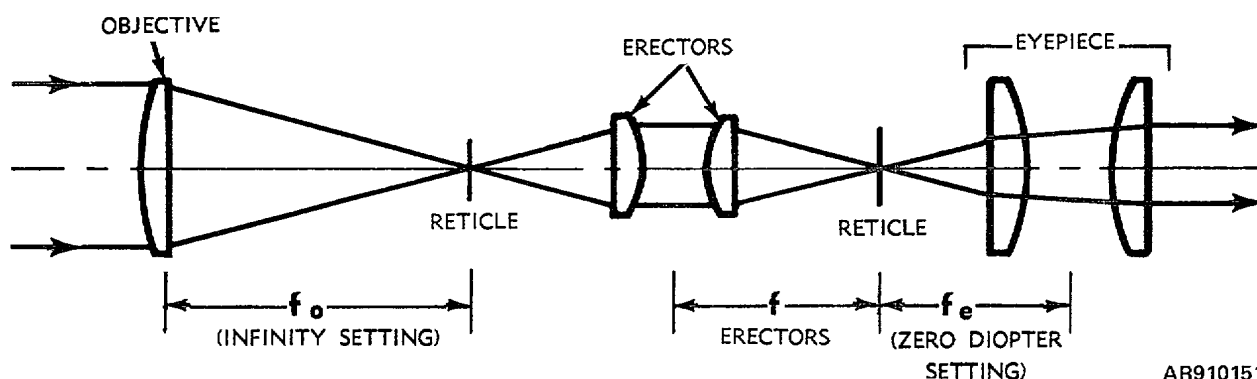

AR910151

Figure 5-23. Reticle location

**5-20. Galilean-Type Rifle Sight.** In this British-devised system, a long focal length objective (bearing a reticle to its front surface) is mounted in place of an open front sight. A negative eyelens and aperture replace the conventional peepsight. The aperture provides sharper definition and limited parallax by use

of the principle of universal focus through a small aperture (familiar to most marksmen). In such a system, it is impossible to have both reticle and target image in sharp focus simultaneously. Note also that the reticle actually is outside the system. A reticle cannot be placed *within* this system as no real image plane

exists. Also, the negative eyelens alone would minify the reticle and require eye accommodation to focus on it so that it would be impossible to see both field and reticle

simultaneously with the same accommodation. Although this system is of basic optical interest, it has no practical military application in this country.

**Section VII. OPTICAL FACTORS IN TELESCOPE DESIGN**

**5-21. Magnification or Power of Telescope.** Power in a telescope can be determined by dividing the diameter of the entrance pupil by the diameter of the exit pupil.

$$\text{Power} = \frac{AP}{EP}$$

where AP is the diameter or aperture of the entrance pupil and EP is the diameter of the exit pupil (fig 5-24).

This formula is applicable to all types of telescopes.

**NOTE**

Power in optical instruments is denoted by the letter x. For example, a 6 x 30 binocular is 6-power and has an entrance pupil or objective size of 30 millimeters.

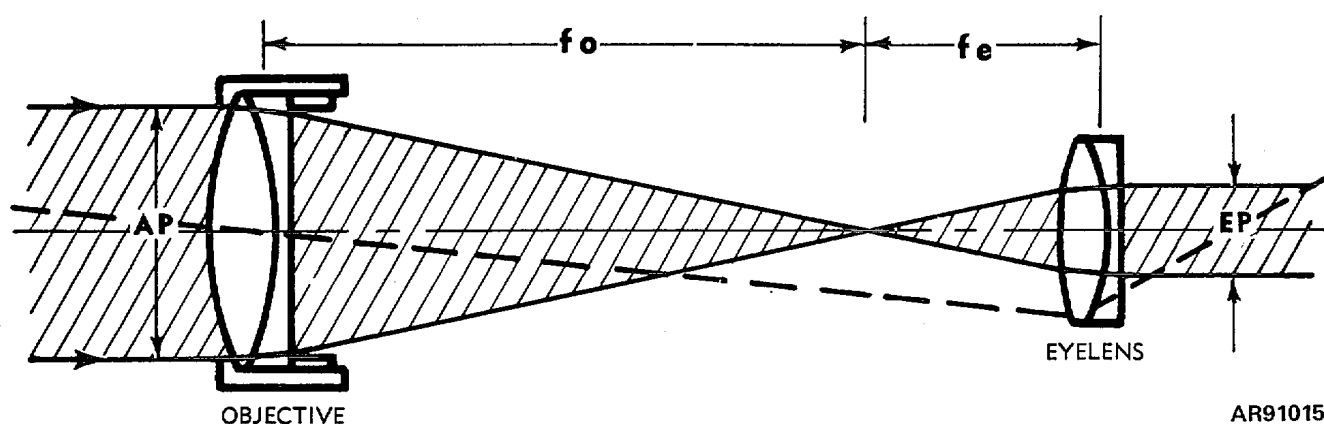

Figure 5-24. Entrance and exit pupils.

**5-22. Entrance Pupil.**

*a. Function.* The entrance pupil diameter is limited by the *clear aperture diameter* of the objective lens. This clear aperture is limited by the inside diameter of either the lens cell or the retaining ring as indicated in figure 5-24. The entrance pupil can be viewed as such from the objective end of the instrument.

*b. Measurement.* The entrance pupil can be approximated by measuring directly across the objective with a transparent metric scale. Usually the above method is sufficiently accurate for most practical purposes.

**5-23. Exit Pupil.**

*a. Location.* The diameter of the bundle of light (figs 5-24 and 5-25) leaving an optical system is determined by the size of the exit pupil. If an instrument is held at arm's length, the exit pupil is seen as a virtual image of the aperture stop and will appear as a bright disk of light (fig 5-25). The position of the exit pupil can be determined by directing the telescope towards an illuminated area, such as the sky, and by holding a piece of translucent paper or ground glass behind the eyepiece in the place where the emergent beam is smallest and most clearly defined. This disk of light formed at the exit pupil is called the *eye circle* or *Ramsden circle*.

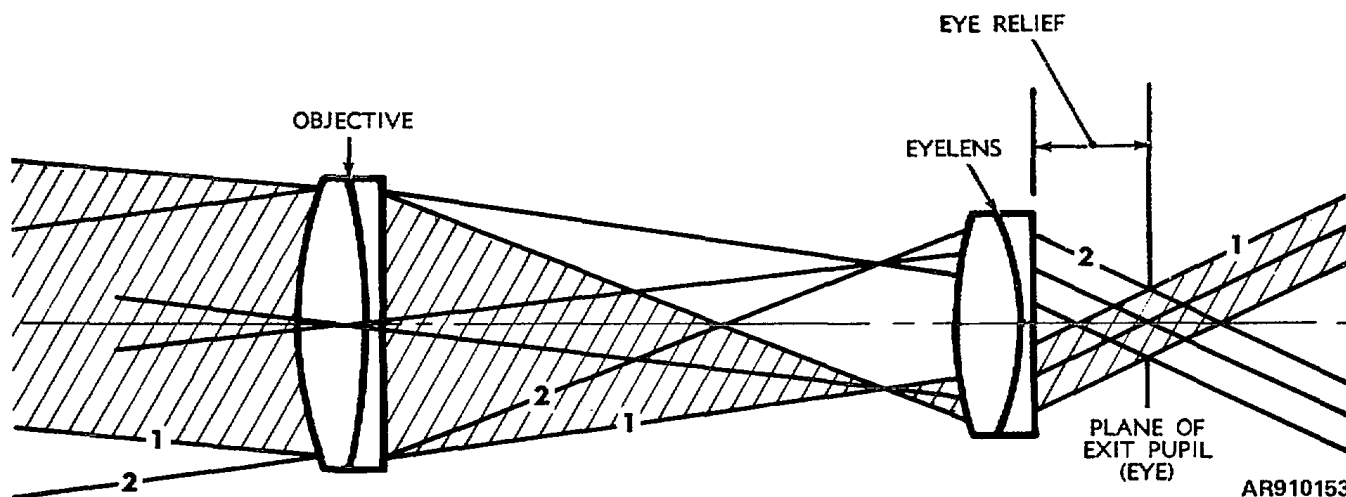

AR910153

Figure 5-25. Exit pupil-virtual image of objective.

b. *Plane.* In figure 5-25, rays 1 and 2 originating at opposite limits of the true field (para 5-25) cross at a common point in the objective lens and recross back of the eyepiece in the plane of the exit pupil. In the exit pupil plane must be the point of rotation of the observer's eye if the observer is to see the full field.

c. *Diameter.* The diameter of the exit pupil can be measured by pointing the telescope toward a light source (out a window) and inserting a piece of translucent material in the plane of the exit pupil (para 9-3). The diameter of the image then can be measured on the paper. This diameter also can be approximated by holding the telescope away from the eye and measuring across the eyelens the diameter of the bright disk seen through the eyelens or it can be measured quite accurately by using a dynamometer (para 5-24).

**5-24. Ramsden Dynamometer.**

a. *Basic Use.* The Ramsden dynamometer (fig 5-26) is used in measuring the position and diameter of the exit pupil. The dynamometer is essentially a magnifier or eyepiece with fixed reticle. The eyepiece and the reticle move as a unit within the dynamometer tube. When in use, the dynamometer is placed between the eye and the eyepiece of the instrument and focused until the bright disk of the exit pupil is sharply defined on the dynamometer reticle. The diameter of the exit pupil is then measured directly on the dynamometer reticle (usually graduated in 0.5 millimeters) and the eye distance or eye relief is read from the scale on the dynamometer tube.

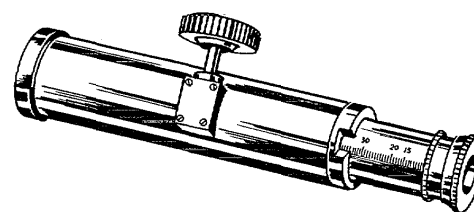

AR910154

Figure 5-26. Ramsden dynameter.

b. *Purpose of Measurement.* Measurement of exit pupil and entrance pupil diameters of an instrument is useful in determining the power of an unknown, or for example, a foreign instrument by the use of the equation:

$$\text{Power} = \frac{AP}{EP}; \text{ (para 5-21).}$$

If the power is known and the diameter of the exit pupil is desired (and a dynameter is unavailable), it is usually easier to measure approximately the entrance pupil and compute the diameter of the exit pupil.

**5-25. True and Apparent Fields of Telescope.**

a. *Definitions.* The true field of view in a telescope is the width of the target area or field that can be viewed. It is expressed as either *angular true field* or *linear true field* (figs 5-27 and 5-28). The former is the angle at the objective included by the two extreme principal rays which will enter the observer's eye. The





view is thus *inversely related* to eye relief. If the eye relief is shortened and the aperture of the erectors is increased accordingly, the field of view will be increased without requiring any increase in eyepiece aperture. If the size of the eyepiece is increased and erectors are of corresponding aperture, the field of view will be increased for the same eye relief.

**NOTE**

Conversion of angular field to linear field:  
 $LF = \frac{2aR}{E}$ , where LF equal Linear Field, R equals  
 E

Range, "a" equals Angular True Field measured from the axis, and E equals 1 Radian which equals 57.3° (approximately).

**5-27. Factors Determining Eye Relief of Telescope.**

*a. Definition.* Eye relief is the distance from the rear surface of the eyelens to the plane of the exit pupil in which the eye must be positioned to view the full field (para 2-34). Eye relief can be, and usually is, short in high-power observation instruments. In a binocular, it is quite short. Eye relief must be long in rifle scopes or gunsights where recoil is to be considered. Its location will depend on the location of the real image ( $O'$  in figs 5-29, 5-30 and 5-31) of the aperture stop (objective) formed by the erectors. The closer this is to the eyepiece the greater is the eye relief.

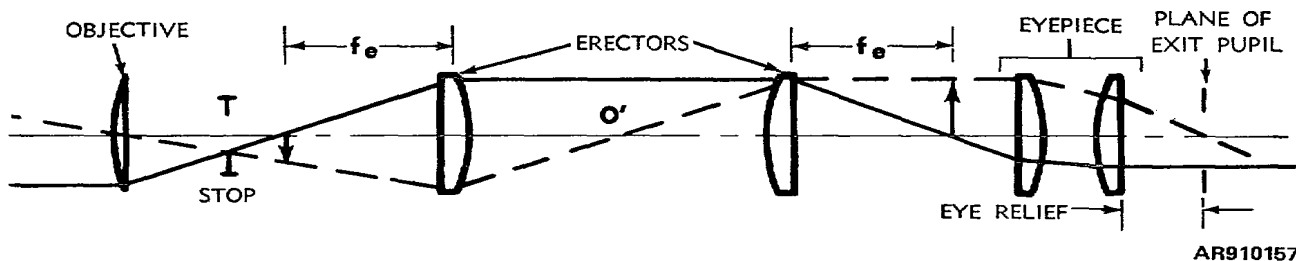

Figure 5-29. Eye relief-symmetrical erectors with real images at focal points of erectors and image  $O'$  of objective between erectors.

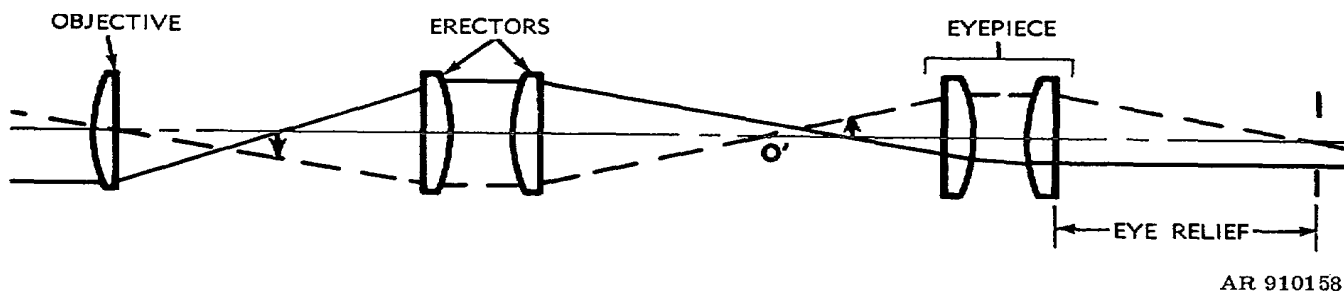

Figure 5-30. Eye relief-objective image outside erectors.

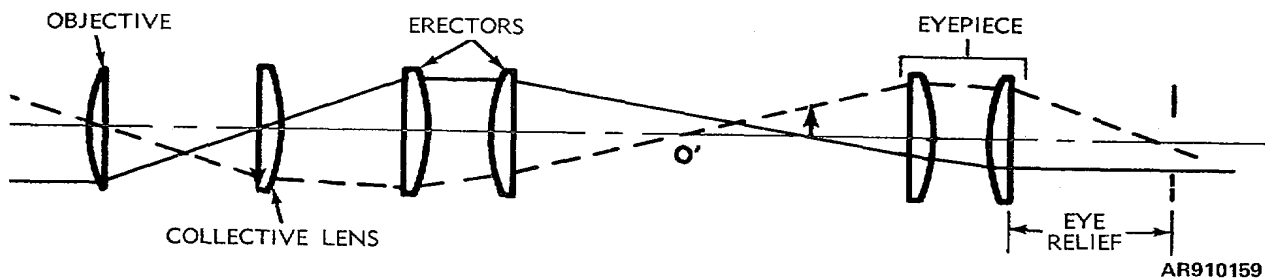

Figure 5-31. Eye relief-collective lens in system.

*b. Effects of Field Lenses.* A field or collective lens in the focal plane of the objective will shift this image forward and shorten the eye relief (the stronger the lens the farther the shift). For this reason, a collective lens usually is not used in a rifle scope. It

would make the eye relief too short in most cases for the recoil. As mentioned in the note attached to paragraph 5-13b, the field lens in the eyepiece shortens eye relief by shifting the plane of the exit pupil without affecting its size.

c. *Power of Eyepiece.* Eye relief also is inversely related to the power of the eyepiece; i.e., replacing a low-power eyepiece with one of higher power will reduce the eye relief.

**5-28. Light Transmission or Illumination.**

a. *Pupils.* The illumination of the image depends on the amount of light received by the objective and the specific intensity (whether bright daylight or twilight) of these light rays. The amount of light received is determined by the diameter of the entrance pupil (clear aperture, abbreviated as AP) of the objective. The amount of light entering the eye is limited either by the exit pupil of the instrument or the pupil of the eye, whichever is smaller.

(1) An 8 x 30 (8-power, 30-mm diameter) glass in daytime (eye pupil diameter of 5 millimeters), since amount of light entering the instrument is proportional to area of entrance aperture and thus to the square of its diameter, picks up  $(30/5^2)$  or 36 times as much light as the naked eye. The area of the retinal image in the eye, however, is  $8^2$  or 64 times as large as with the unaided eye. Thus, we have 36 times as much light distributed over an area 64 times as great, so illumination on the retina is only  $36/64$  or 56.3 percent of that with the unaided eye.

(2) Consider now an 8 x 40 binocular. In this case the amount of light entering the eye is  $(40/5^2)$  or 64 times that entering the unaided eye. There is now 64 times as much light falling on an area 64 times as large (power is 8, thus the comparative area of the retinal image is  $8^2$ ). In this case, illumination is the same as with the unaided eye.

(3) In an 8 x 50 glass, illumination will not increase with a 5-millimeter eye pupil because the iris of the eye will stop and the extra light from the extra 10 millimeters of diameter of the objective. Since,

$$\text{Power} = \frac{\text{Entrance Pupil}}{\text{Exit Pupil}} \quad (\text{para 5-21}).$$

the exit pupil of this 8 x 50 glass is  $50/8$  or 6.25 millimeters; therefore, the eye pupil of 5 millimeters will not admit all this light.

b. *Maximum Illumination.* For maximum

illumination at any given light intensity, exit pupil of instrument must equal entrance pupil of eye under the same condition. Also, with any instrument, retinal illumination never is greater than with the unaided eye. Opaque foreign material such as dust or lint on any optical surface, except one in a real image plane, will reduce the illumination of the system.

**5-29. Night Glasses.** When subjected to intense illumination (brilliant daylight), the entrance pupil of the eye may be stopped down to 2 millimeter diameter. When used under this illumination, an optical instrument need have an exit pupil only 2 millimeter diameter. When the eye is subjected to very faint illumination, as at night, the pupil opens to a diameter of 8 millimeters. Thus, for use at night an optical instrument must have an *exit pupil* of at least 8 millimeters provide the pupil of the eye with all the light it will admit. The relationship between the size of the exit pupil and the power of an instrument is important. For example, a 7 x 50 binocular is suitable for nighttime use because if the clear aperture of the objective (50) is divided by the power of the binocular (7) (para 5-21), the exit pupil diameter is determined to be 7.15 millimeters. This is able to pass approximately all the light the eye pupil can use at its widest aperture. Now a 7 x 35 binocular provides ample illumination in daytime because its exit pupil diameter is 5 millimeters, which is larger than the eye's 2-millimeter opening under intense illumination and ample for its 5-millimeter opening under moderate illumination but insufficient for the 8-millimeter eye opening at night.

**5-30. Resolving Power of Optical Systems.**

a. *Definition.* The numerical measure of ability of an optical system to distinguish fine detail is called resolving power. It is further defined as the reciprocal of the smallest angular separation (angular limit of resolution) between two points which can be distinguished or resolved as separate points. Resolving power =  $1/\alpha$ , where  $\alpha$  = least angular separation in radians (fig 5-32). As the angle becomes smaller between two points that can be resolved, the resolving power increases and definition, therefore, is better.

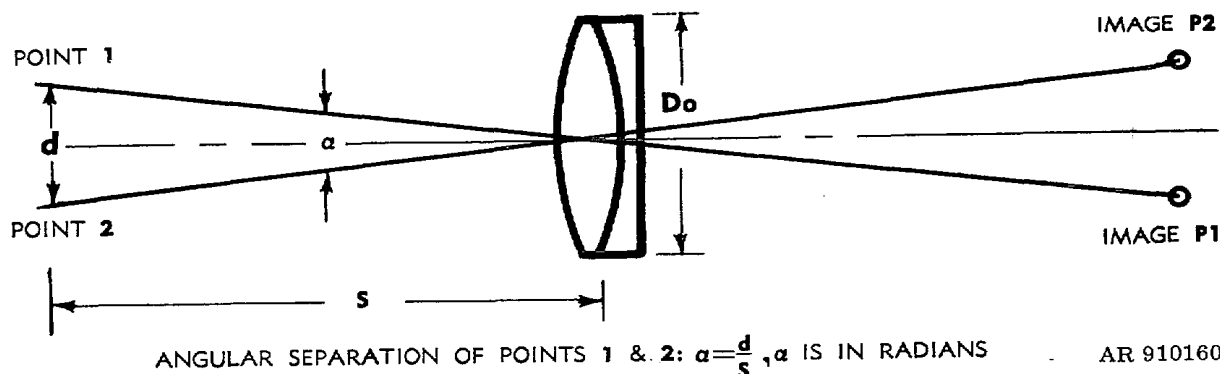

Figure 5-32. Angular limit of resolution.

b. *Controlling Factor.* The angular limit of resolution can be proved to be related inversely to the diameter of the lens. According to Dawes' rule (an approximation):  $a$  (in minutes of arc) =  $1/D_o$  (in fifths of an inch, fig 5-32); thus it is advisable to have large objectives for sharp definition. The observation telescope has such an objective of large diameter. The target shooter uses a telescope of 1 1/4-inch diameter objective or larger. The 7 x 50 (7-power, 50-millimeter diameter) binocular provides good resolution because of the large diameter objective and for this reason is better in daytime than a 7 x 35.

c. *Normal Magnification.* Normal magnification is that power of a telescope giving an exit pupil diameter just equal to that of the eye usually standardized at 2 millimeters (Some authorities, however, consider the eye to provide the best resolution at an aperture of 4 to 5 millimeters.) For example:

$$\text{Normal magnification} = \frac{D \text{ (Objective)}}{C \text{ (Pupil of Eye)}}$$

or, normal magnification = 25.4  $D_o$  over 2 to 4, where  $D_o$  is in inches.

Normal magnification is one of three factors limiting the magnifying power obtainable with a given objective lens. The other two factors are the resolving power of the given lens ( $RP = 1/\alpha$  para 5-30a) based on diffraction effects, and the quality of the lens (precision of grinding and polishing and absence of aberrations) measurable by laboratory methods (fig 5-32).

d. *Other Resolving Factors.* The foregoing equations are in agreement if the entrance pupil of the eye is 2 millimeters. The plus 2 to 4 results in empty magnification, an increase in image size of fine details so the eye can more readily see them, but without any increase in telescopic resolving power. For best resolution, the power of the eye piece in the system is determined by the formula:

$$\text{Pupil X} \frac{\text{Focal Length Eyepiece} = \text{Diameter Eye}}{\text{Focal Length Objective}} \\ \frac{\text{Diameter of Objective}}$$

**NOTE**

All values in this formula are in millimeters. Although the resolving power of the human eye normally is equal to 1 minute of arc, for long continued observation this becomes 2 or 3 minutes (due to fatigue). This, for continuous observation an instrument of greater power is needed to provide the same definition obtainable with a lower power telescope used for short intervals. Transparent foreign material such as grease or fingerprints on a lens will impair definition (resolving power). Opaque foreign material on the eye-lens either may impair definition or blot out small portions of the field.

**5-31. Optical Glass Used in the Design of Military Instruments.**

a. *Common Types.* Although there are numerous types of optical glass in the design of optical systems for military instruments, five types in common use are as follows:

Name	Index of refraction	Critical angle in degrees
Boro silicate crown	1.5170	41
Barium crown	1.5411	40
Baryta light flint	1.5880	39
Ordinary flint	1.6170	38
Dense flint	1.6490	37

It will be noted that as the index of refraction increases, the critical angle decreases.

b. *Specific Uses.* Boro silicate crown normally is used for the collective lenses and dense flint for the dispersive lenses in objectives, erecting lenses, and eyepieces. In the Kellner eyepiece (A, fig 4-5), boro silicate crown is used for the field lens, barium crown for the collective element, and either light flint or ordinary flint for the dispersive element of the achromatic doublet eyelens. Prisms, generally, are made of boro silicate crown. For wide-angle instruments, however, baryta light flint is used. Reticles are usually made of baryta light flint because it etches best and windows usually are of boro silicate crown.

## CHAPTER 6

## PRINCIPLES OF LASERS

**6-1. General.** Simply defined, a laser (Light Amplification by Stimulated Emission of Radiation) is a light-emitting body with feedback for amplifying the emitted light. The laser is a unique, and highly specialized source of light; the beam of light it produces has three significant characteristics, namely, laser light is monochromatic, highly collimated, and coherent. Although light possessing the first two properties can be produced by some conventional light sources, only laser light possesses all three properties. In addition, the laser beam is a powerful and very intense light source.

**6-2. Types of Lasers.**

a. There are essentially four types of lasers:

(1) Solid state rod-type lasers use materials such as a ruby rod of about 1 centimeter in diameter and 15 centimeters long as an elementary light emitter or generator.

(2) Semiconductor diode-type lasers use material such as gallium arsenide and consist of a junction formed by p-type material and an n-type material. In this type of laser, stimulation to laser emission occurs by passing a current through the junction.

(3) Gas-type lasers use helium-neon, argon, carbon dioxide, nitrogen and Xenon. In this type of laser, stimulation to laser emission occurs by passing a current through the gas. The current causes the gas to ionize and radiate. The radiation oscillates within a tube provided with mirrored ends and then discharges

from the partially mirrored end of the tube.

(4) Liquid-type lasers consist of solutions such as coumarine and rhodamine red. In this type of laser, the liquid-laser materials are stimulated to emission by irradiating the lasing liquid or dye solution with another laser beam.

b. Although the heart of a laser is a light wave amplifier, the device produces a beam when it oscillates. The laser is, therefore, a special kind of oscillator, but it will optically behave in the same manner as ordinary light. For this reason, only gas lasers and solid-state rod-type lasers, are described in detail.

**6-3. Gas Lasers.**

a. A gas laser is structurally a simple device, and in many ways it is similar to neon electric signs. A gas laser (fig 6-1) consists of a thin glass tube about 1 foot long, and filled with a low-pressure mixture of helium and neon gases. A pair of electrodes, a negative cathode and a positive anode, are mounted near the ends of the tube. These electrodes are connected to a high voltage, direct current power supply. The electric field produced between the two electrodes breaks down the column of gas, instantly transforming it from a poor conductor of electricity into a relatively good conductor. A continuous electric glow discharge takes place within the glass tube, and produces a continuous electric current flow between cathode and anode through the partially ionized column of gas.

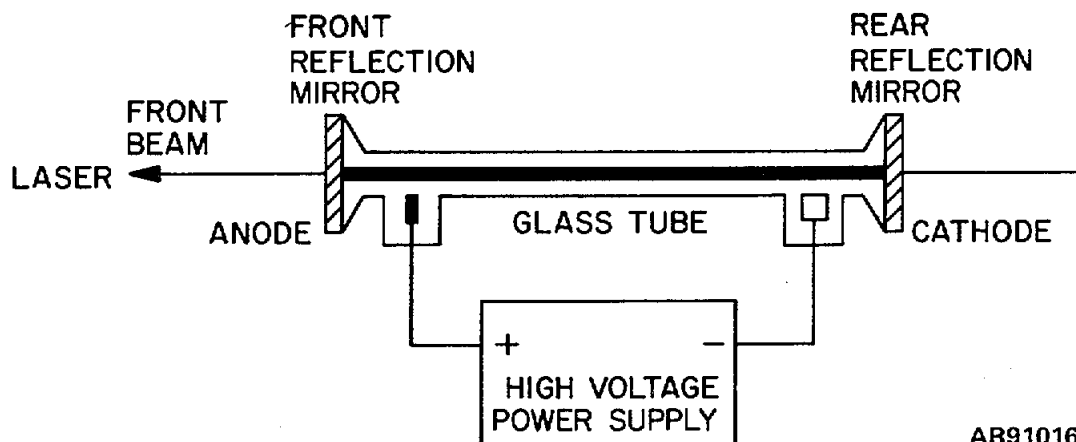

Figure 6-1. Gas laser.

b. The tube emits a reddish-orange neon glow because the electric discharge causes countless collisions among the gas atoms that excite them to high energy states; the atoms randomly fall back to their normal energy state, and, in so doing, emit a bundle of light energy photons. In a conventional neon sign, these up and down energy shifts take place at random within the glowing gas column.

c. The mixture of gases in the laser tube has been carefully selected so that more neon atoms are in high energy states than in low energy states when the discharge occurs; it is the neon gas that is responsible for lasing. That is, as the discharge excites the helium atoms, they collide with the neon atoms and transfer energy to the neon atoms. This transfer of energy to the neon atoms raises their energy state. Stimulated emission of photons can now take place within the column of glowing gas. This occurs when an excited neon atom drops to a lower energy level and emits a light wave. As the light wave speeds past other excited atoms, it stimulates them to emit their photons. This process of amplification continues, since one photon entering the column of gas at one end causes other photons to be emitted. The reflecting mirrors at the front and the rear of the glass tube cause any light waves emitted in the direction of the tube to bounce

back and forth along the gas column establishing a continuous lasing action.

d. The electric discharge continuously pumps the neon gas atoms to higher energy states, and, at the same time, light waves bouncing between the mirrors stimulate the excited atoms into emitting their packets of light energy. As a result, a steady stream of coherent, monochromatic light is generated within the column. The laser tube's front mirror is designed to be partially transmitting, i.e., it is designed to reflect 99% of the light that hits it, and allow the other 1% to pass through. This small portion of the laser light generated within the tube passes through the front mirror as a narrow light beam; its wavelength is 633 nm, and it is deep red in color.

**6-4. Solid State Rod Lasers.**

a. A ruby rod solid state laser consists of an elementary light emitter or generator that is illuminated by a high-intensity light (A, fig 6-2). The high-intensity light, such as that from a photoflash lamp, makes the rod fluoresce with a pink color. The fluorescence persists as long as the photoflash light persists. This effect is not a laser radiation, but just another optical characteristic of the emitter. The ruby rod produces a characteristic pink color because it is made of aluminum oxide (sapphire) containing 0.05 % chromium.

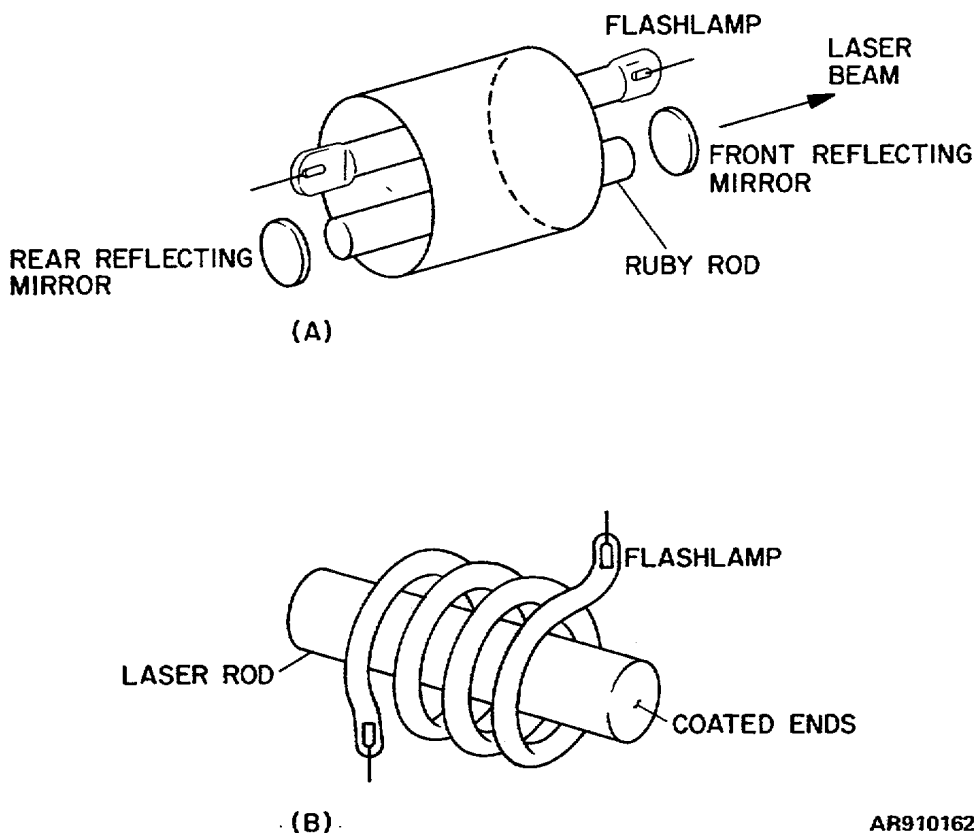

AR910162

Figure 6-2. Solid-state rod lasers.

*b.* In laser radiation, the ends of the ruby rod are highly polished so that light can pass through almost without absorption. A mirror is placed at each end and aligned perpendicularly to the principal axis of the rod. When the rod is illuminated with an intense photoflash light, it emits a fluorescent light which reflects back and forth between the two mirrors. This increase in intensity of the light is produced by the oscillation of the ruby light within an optically resonant cavity formed by the rod and the two reflecting surfaces of the mirrors.

*c.* The removal of the laser energy, or radiation, from the resonant cavity is accomplished by making the rear reflecting mirror 100% reflective and the front reflecting mirror partially reflective. This allows some of the laser light generated within the resonant cavity to pass through as a laser beam of the same diameter as the ruby rod

*d.* During the optical pumping of the ruby rod by the flashlamp, some of the chromium in the ruby rod become excited. This causes their electrons to move away from the atoms and position themselves at higher energy levels from which they spontaneously fall back to their normal energy states. During this transition, each of these electrons produces a photon of light. These photons now oscillate by reflecting from one mirror surface to the other within the resonant cavity. On their way to the mirror, some of the photons collide with one or more atoms which are in an excited state due to the flashlamp pumping, and interact with them to produce a photon or photons identical in energy and frequency with the initial photon. The newly formed photons continue to interact with other excited atoms, producing more

photons, and these photons continue interacting to produce still more photons. When a threshold energy of the total photonic energy within the resonant cavity is attained, a pulse, consisting of a very intense laser beam formed by photon waves, bursts out of the partially reflective end of the ruby rod.

*e.* In practical applications the highly polished ends of the ruby rod can be mirrored or coated with a dielectric material, such as magnesium fluoride or cerium dioxide (B, fig 6-2). When this is done one end is fully coated and the other is partially coated so that the emitted laser light can pass through it. This laser beam, as it emerges from the ruby rod, has a slight divergence.

#### **6-5. Laser Optics.**

*a.* The extremely tight beam produced by the laser, with final tightening obtained by external optical systems, gives it the ability to travel extreme distances with little divergence. The laser output can be focused to a parallel beam where spreading is expected to be less than one foot per mile of travel. A beam of light from a ruby laser would suffer so little divergence that, for example, it would be concentrated in an area ten miles across when it reached the moon; an ordinary search light with the same intensity would place a beam over 25,000 miles wide on the moon.

*b.* Brightness may approach millions of times that of the sun, on a relative bandwidth basis. Spectral narrowness allows good signal to background ratios to be realized. Compared to microwave systems, laser devices will allow construction of equipment with an antenna only inches across.

## CHAPTER 7

## INFRARED PRINCIPLES

**7-1. General.** Infrared light is considered to be radiant energy in the band of wavelengths between about 0.76 and 100 microns. The portion of the band between 0.76 and 3 microns is sometimes referred to as near infrared light, and the portion between 3 and 100 microns has been called far infrared light. Most of the infrared light band overlaps the heat radiation band of electromagnetic radiation. By definition, infrared pertains to or designates those radiations, such as are emitted by a hot body, with wavelengths just beyond the red end of the visible spectrum.

**7-2. Infrared Radiation.**

a. The term infrared radiation is used to describe electromagnetic radiation whose wave-length lies just beyond the red end of the visible spectrum, and the beginning of the region that can be detected by microwave radio techniques. The distinction, for example, between infrared astronomy and radio astronomy is, therefore, an arbitrary one based entirely on differences in detection techniques.

b. A study of source characteristics is important because of the help such knowledge provides in the choice of detectors and the design of optical elements. In many applications the radiation source is not subject to control. This is most often true for passive systems where the objects are detected by their natural radiation. It also may be true for those active systems that use a source for the illumination of a scene so that objects may be detected by the reflected radiation.

c. The natural division or grouping of infrared sources depends upon the nature of the wavelength distribution of the emitted energy. One type of source emits radiation over a very broad and continuous band of wavelengths. A plot of its emission versus wavelength is a smooth curve which usually passes through only one maximum. This type is called a continuous spectrum source, or simply a continuous source.

d. Another type of source is one which radiates strongly in some relatively narrow spectral intervals, but, in other wavelength intervals, the source does not radiate at all. A plot of emission versus wavelength reveals a series of emission bands or lines. The curve is discontinuous and the source is called a

discontinuous spectrum source, a line source, or a band source.

e. An intense source of infrared radiation can be devised using the maser (Microwave Amplification by Stimulated Emission of Radiation) principle. This type of source is very directional, is concentrated within a narrow spectral interval, and possesses a high degree of coherence.

**7-3. Thermal Radiation.** The electromagnetic energy that is emitted from the surface of a heated body is called thermal radiation. This radiation consists of a continuous spectrum of frequencies extending over a wide range. The spectral distribution and the amount of energy radiated depend chiefly on the temperature of the emitting surface. Careful measurements show that at a given temperature there is a definite frequency or wavelength at which the radiated power is maximum, although this maximum is very broad. In addition, the frequency of the maximum is found to vary in direct proportion to the absolute temperature. This rule is known as Wien's law. At room temperature, for example, the maximum occurs in the far-infrared region of the spectrum, and there is no perceptible visible radiation emitted. But at higher temperatures, the maximum shifts to correspondingly higher frequencies. Thus at about 5000C and above, a body glows visibly.

**7-4. Infrared Detectors.**

a. The central element in any infrared detection system is the detector. This is the device which transduces the energy of the electromagnetic radiation falling upon it into some other form (in most cases, electrical). The mechanisms used to perform this function are broadly classified as either photon detectors or thermal detectors.

b. When radiation of wavelength less than a critical value falls upon the surface of certain materials, electrons are emitted from the surface. Photo tubes using this photoemissive effect are very widely used. However, the nature of the effect is such that photoemissive detectors operate in the ultraviolet, visible, or very near infrared. The photoemissive effect, also termed the external photoelectric effect or simply the photoelectric effect, was discovered by Hertz in 1887 and explained by Einstein in 1905. The image converter is the only type of detector which has found much application in infrared technology, but its use is

limited to the very near infrared. The most elemental form of photoemissive cell is the vacuum photocell, consisting of a photo cathode and an anode in an evacuated enclosure.

c. The photon effect most widely used in infrared detection is photoconductivity. The reason for this is that photon effects in general are faster and more efficient than thermal effects, and photoconductivity is the most simple of the photon effects. Photoconductive detectors as a class are easier to produce and easier to use than detectors based upon the other photon effects. The photoconductive detector (fig 7-1) is placed in the input circuit of an amplifier. In order to detect the

change in conductivity of a photoconductor upon exposure to radiation, it is also necessary to supply a bias battery and a load resistor. The photoconductor of dark resistance  $R$  is placed in series with a load resistor  $R_L$  and a bias battery  $V_b$ . Infrared radiation, which is modulated or chopped, is absorbed by the photoconductor, thereby causing its resistance to decrease with a corresponding increase in the current flowing in the circuit and a greater portion of  $V_b$  to appear across  $R_L$ . The voltage appearing across  $R_L$  is coupled through capacitor  $c$  to the input circuit of the amplifier, and represents the radiation absorbed by the photoconductor.

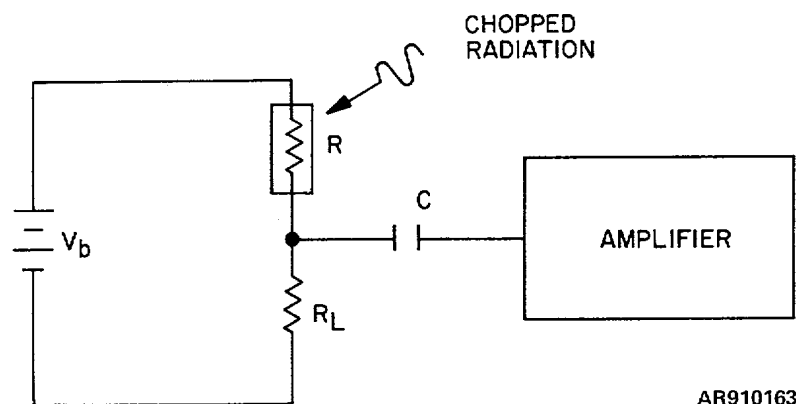

AR910163

Figure 7-1. Photoconductive detector.

d. Another internal photo effect of interest in known as the photovoltaic effect. As the name implies, the action of photons in this case produces a voltage which can be detected directly without need for bias supply or load resistor. In addition to the photovoltaic detector, the operation of the photodiode and the phototransistor are based upon this effect. That is, as long as radiation falls upon the p-n junctions within the body of a semiconductor, electronhole pairs will be formed and separated by the internal field at the junction. If the semiconductor ends are short circuited by an external conductor, a current flow in the circuit. On the other hand, if the ends are open circuited by a high impedance voltage measuring device, a voltage will exist as long as radiation falls upon the p-n junction.

e. Thermal detectors make use of the heating effect of radiation. They are simply energy detectors and their responses are dependent upon the radiant

power which they absorb. The most well known forms of thermal detectors are the bolometer and the thermocouple. The bolometer has seen widespread military use, while the thermocouple has found extensive commercial application.

f. A bolometer is a radiant power detecting device, the operation of which is based upon measuring the temperature change in resistance of a material due to the heating effect of absorbed radiation (fig 7-2). The simplest form of bolometer is a short length of fine wire whose resistance at a given temperature is known. Radiation allowed to fall upon the wire is partially absorbed, causing a rise in temperature. The resistance change due to the change in temperature is a measure of the radiant power absorbed. Because bolometers are power detectors, they are capable of detecting radiation of all wavelengths and are widely used as detectors of microwave power.



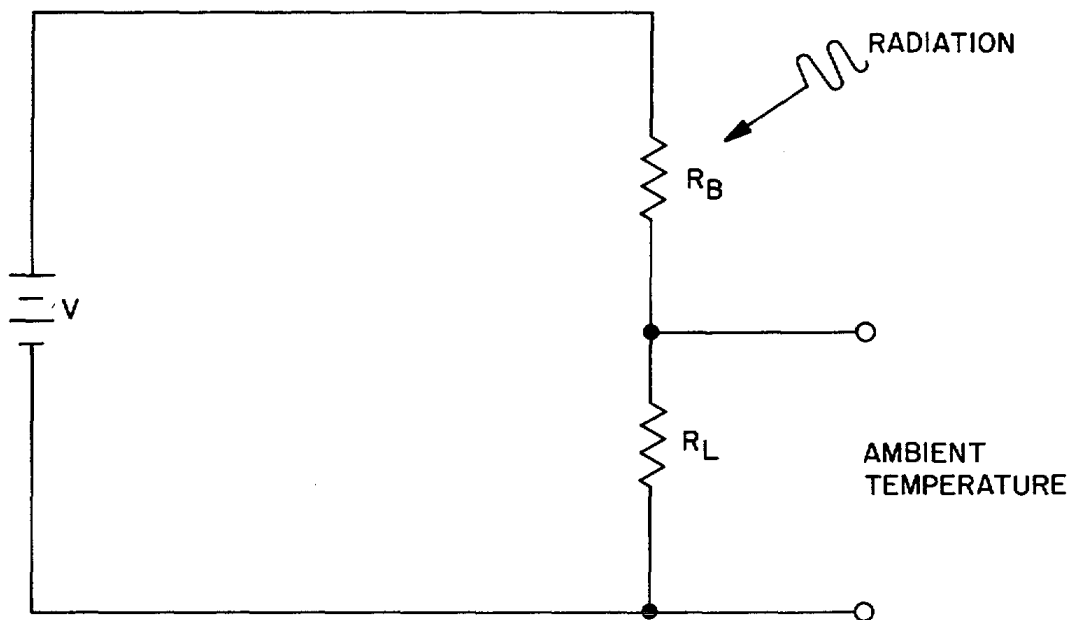

AR910164

Figure 7-2. Bolometer circuit.

*g.* Bolometers may be of three types: metal, semiconductor, and superconductor. Metal and semiconductor bolometers are operated at ambient temperatures, whereas the superconducting bolometer must be cooled to temperatures near absolute zero. A form of metal bolometer used in microwave work consisting of an encapsulated platinum wire is known as a barretter; semiconductor bolometers are known as thermistor bolometers, thermistor denoting thermally sensitive resistors. Unlike a barretter the resistance of a thermistor drops as its temperature rises. This characteristic has caused semiconductors to be much more widely used than metals from bolometers. A superconducting bolometer has the advantage over thermistor and metal bolometers of reduced thermal noise, reduced heat capacity, and a step resistance-temperature curve. On the other hand, the problems

associated with low temperature operation and precise temperature control are severe.

*h.* The radiation thermocouple was one of the earliest infrared detectors. It consists of a junction of two dissimilar metals. Absorbed radiation causes the junction temperature to rise, and the heating of the junction generates a small flow of electric current. This action is responsible for generating a voltage which is proportional to the temperature rise and, therefore, is proportional to the intensity of the radiation. A widely used form of the thermocouple is the radiation thermopile; it consists of a parallel array of thermocouples. The thermopile has a higher response than the thermocouple because of the use of multiple junctions. However, its response time is long and it is not suitable for ac amplification techniques. The fragile construction makes it of little use in applications where it would be subject to vibration and shock.

## CHAPTER 8

## TYPICAL FIRE CONTROL INSTRUMENTS

## Section I. TELESCOPE

8-1. General. Telescope is the standard nomenclature designation for instruments of a number of different types. Some typical telescopes illustrated and described in this section are designed to be used for observation; others are designed to aim weapons. Of these some telescopes are of the *straight tube* type; some observation telescopes are of the *prism-offset* type; other telescopes are of the *articulated*, *elbow* and

*panoramic* types. Telescopes are incorporated in some periscopes, others are used in constructing binoculars and rangefinders.

**8-2. Telescope (Rifle).**

a. The telescope illustrated in figure 8-1 is typical of those designed for use with the rifle for direct fire.

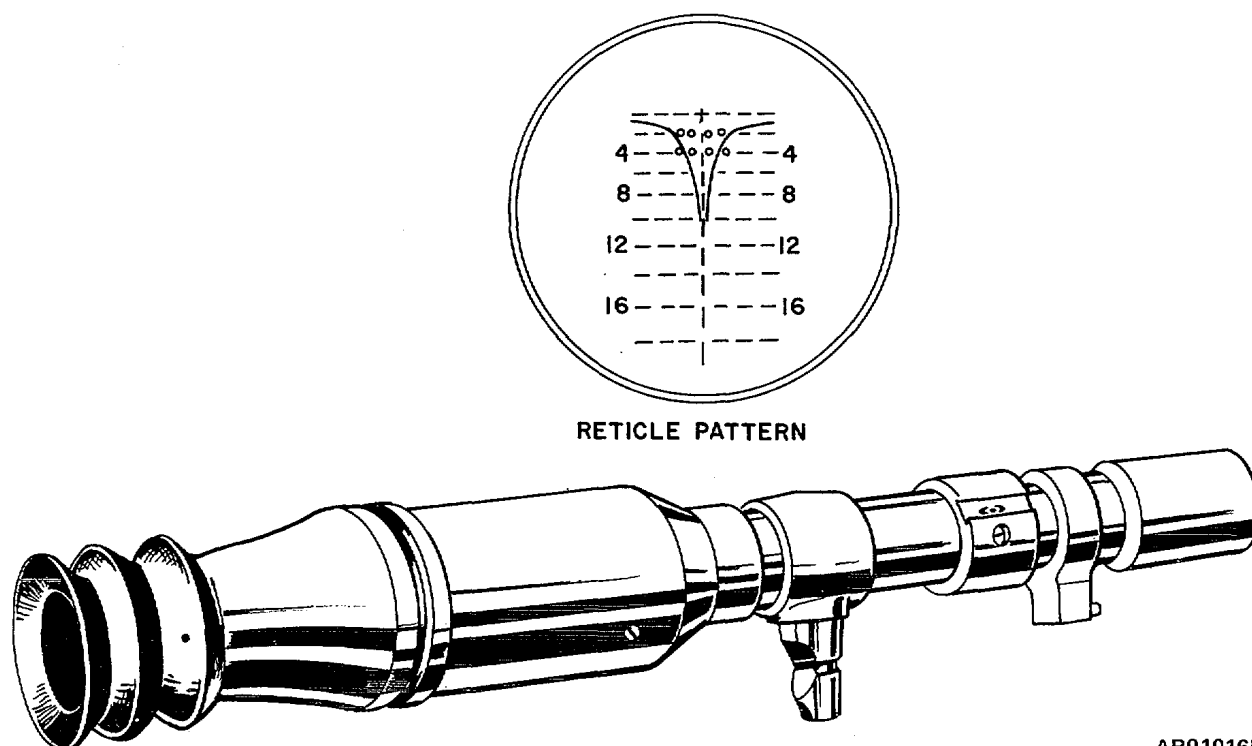

RETICLE PATTERN

AR910165

Figure 8-1. Telescope (Rifle)—assembled view, reticle pattern.

b. The telescope is secured in a rear sight mount which is in turn secured to the rifle so that the telescope and mount move with the rifle in azimuth and elevation. The gunner aims with that part of the reticle which represents the desired deflection and range. The reticle may be illuminated for night operation.

c. This telescope has a slender tube and enlarged eyepiece with a 2.8X magnification and approximately 70 3 minutes field of view.

d. The telescope body is a piece of cold-

drawn seamless steel tubing about 1 inch in diameter with an adapter shrunk onto the rear end. The front end of the tube is enlarged to about 1½ inches to accommodate the objective lens assembly.

**8-3. Telescope (Sniper's Sighting Device).**

a. This telescope (fig 8-2) is a straight tube-type telescope with a fixed focus and is designed for direct sighting. It is typical of those designed for use as a sniper's sighting device with rifles to aid in obtaining more accurate fire.

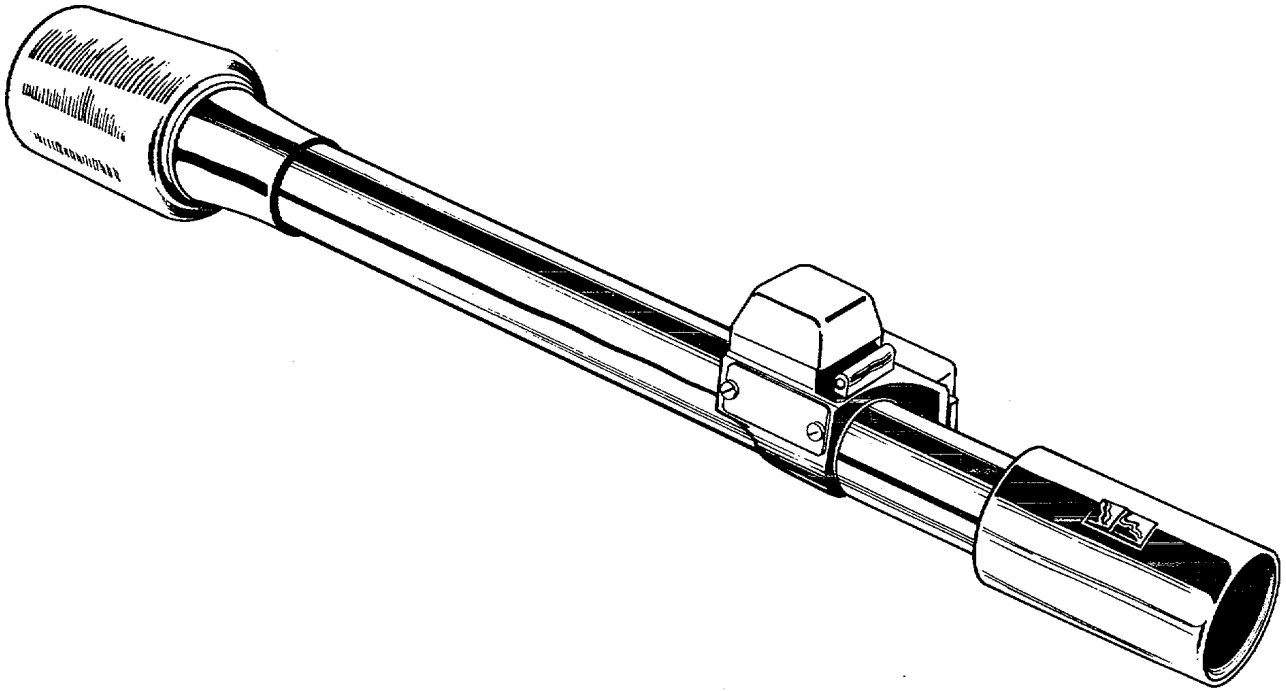

AR910166

Figure 8-2. Telescope (Sniper's Sighting Device)—assembled view.

b. The telescope is characterized by a large bright field of view; has an elevation range knob calibrated from 0 to 900 meters, in 50-meter intervals, causing a total change in elevation of 12.1 mils. A windage knob, having a range of 20 minutes either right or left, is used to correct drift caused by the wind. The telescope has a magnification of 2.2 power.

c. The telescope is equipped with a sunshade to shade the objective and prevent reflections and an eyeshield to position the observer's eye at the proper eye distance.

**8-4. Telescope (Observation).**

a. The observation telescope (fig 8-3) is typical of those designed for observation purposes by the infantry in observing the effectiveness of artillery fire.

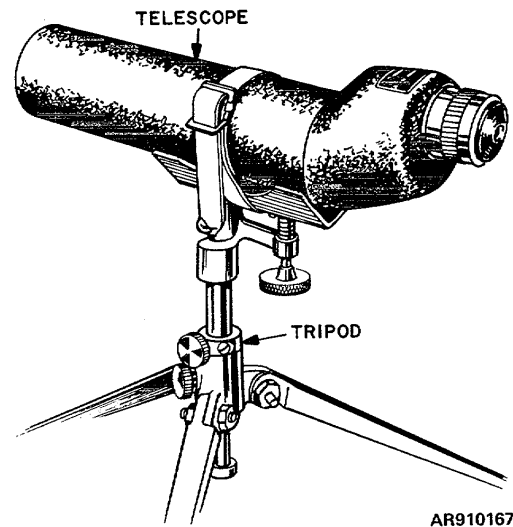

AR910167

Figure 8-3. Observation telescope-assembled view with tripod.

b. The telescope image is erected by means of two Porro prisms and magnified by the lenses in the eyepiece, as shown in figure 8-4.

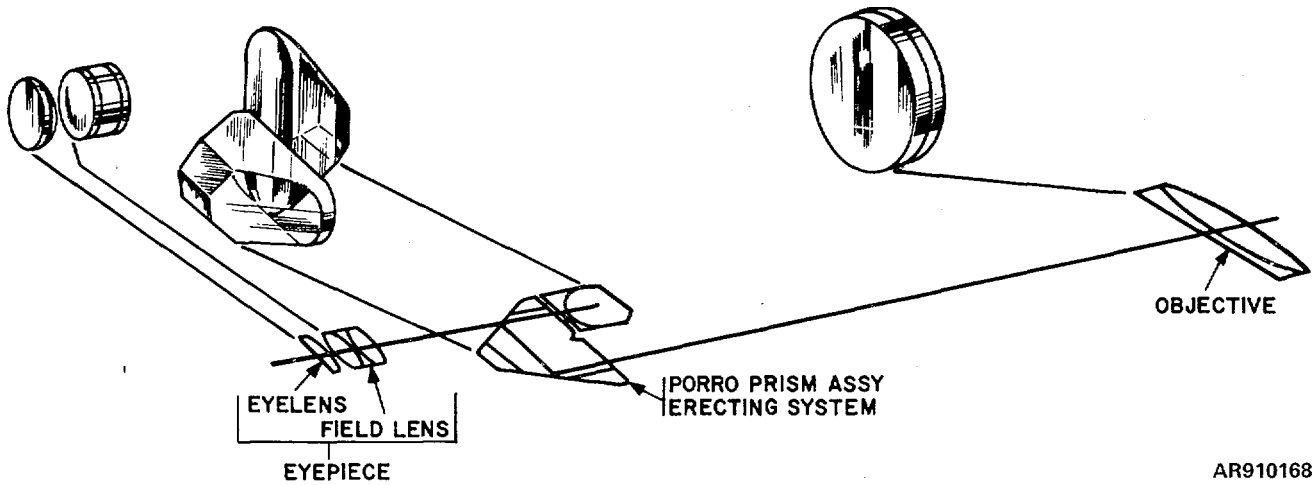

Figure 8-4. Observation telescope-optical elements and optical diagram.

c. The telescope is of 20 x power with a field of view of 20° 12 minutes, is approximately 14 1/2 inches long, is focused by turning the knurled focusing sleeve and is mounted on the tripod which supports the instrument about 11 inches above the ground. With this tripod the telescope can be swung around to any desired position. An elevating

screw is provided for elevating or depressing the forward end of the telescope.

d. The telescope is strapped in position in a cradle which in turn is mounted on the corresponding tripod. The tripod folds into a compact unit and fits into a carrying case for ease and convenience in transportation.

**Section II. ARTICULATED TELESCOPES**

**8-5. General.**

a. The articulated telescope is a component of the direct free control system and is generally

mounted coaxially with the gun.

b. The optical system diagram of one type of articulated telescope is illustrated in figure 8-5.

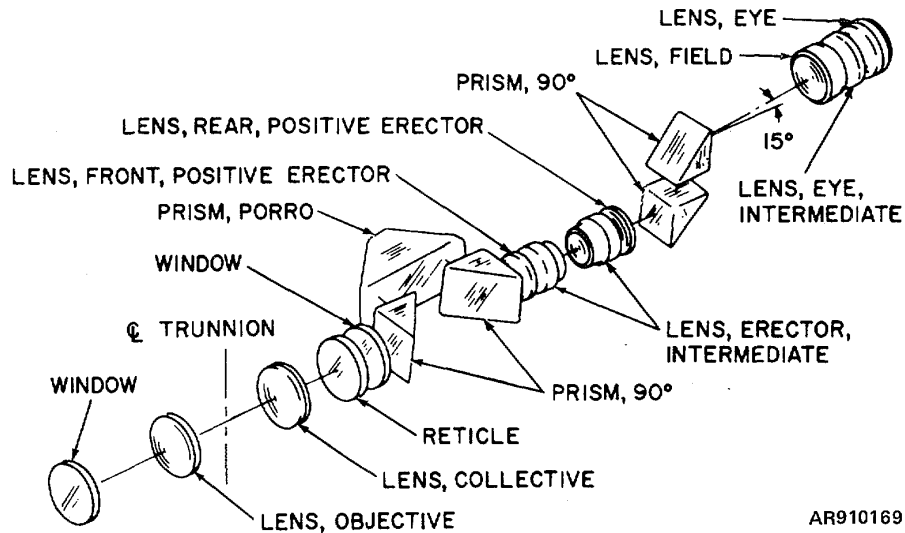
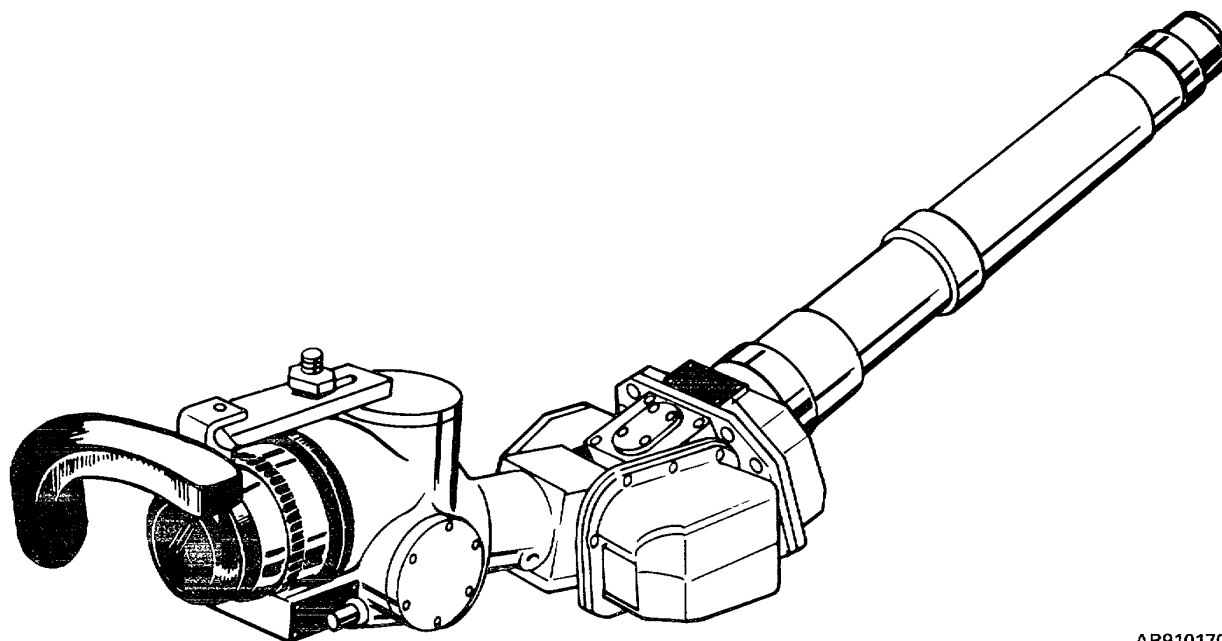

Figure 8-5. Articulated telescope - optical system diagram.

**8-6. Articulated Telescope (Tank).**

a. The articulated telescope illustrated in figure 8-6 is typical of those designed to supplement the primary and more sophisticated tank fire control

system. It is the main part of the secondary, direct, fire control system used by the gunner and is mounted coaxially with the gun.



AR910170

Figure 8-6. Articulated telescope (Tank) - assembled view.

b. The optical system of this articulated telescope is shown in figure 8-5. The telescope has an 8-power magnification with a field of view of 7 1/2 and is used for viewing the target during daylight and periods of artificial illumination.

7.62 mm machinegun, and the secondary fire control instruments for conventional ammunition. The telescope attached to the mount, is coaxially connected with the 152 mm gun/launcher and embodies an articulate joint so that the eyepiece remains stationary and available to the gunner throughout the range of gun elevation and depression. One of two powers, 8X or 12X, may be selected by the gunner.

**8-7. Articulated Telescope (Self-Propelled Vehicle).**

a. The articulated telescope illustrated in figure 8-7 and its associated mount are the primary fire control instruments for the missile system and the

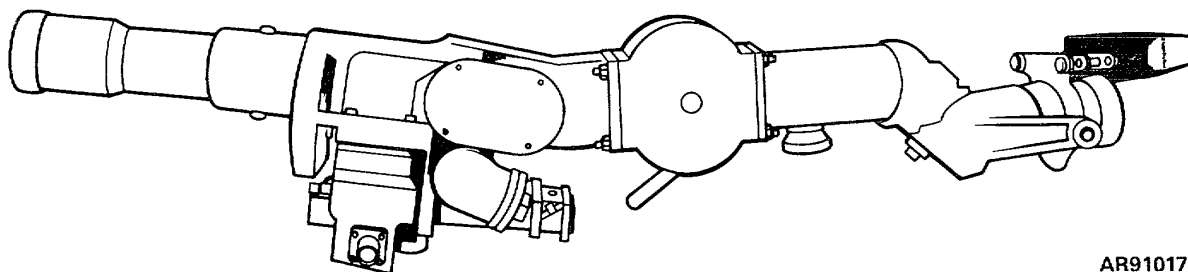

AR910171

Figure 8-7. Articulated telescope ( Self-Propelled Vehicle)-assembled view.

b. The optical system of this articulated telescope forms an inverted image of the viewed target. One of the two reticle patterns is projected into the optical train of the telescope by the beamsplitter and appears superimposed on the

target image. After passing through the prisms in the articulated joint, the inverted image is erected and projected by the power lens erecting system through the offset prisms to the eyepiece.

**Section III. ELBOW TELESCOPES**

**8-8. General.**

a. The elbow telescope is used wherever it is necessary to direct the line of sight through a 90° angle. This is desirable where the range of the angle of elevation of the instrument is considerable. Telescopes of this type are used to permit observers to assume the most convenient positions for the operation of their instruments. Such telescopes are employed in the pointing of recoilless rifles, towed and self-propelled howitzers and guns for tracking the target and fire, and for other purposes.

b. An elbow telescope is essentially the same as a straight tube telescope except that an erecting prism (e.g., Amici) may be used in the elbow to erect the image and also produce the 90° deviation. This eliminates the lens erecting system and shortens the optical system. The schematic diagram of one type of elbow telescope is illustrated in figure 8-8.

c. There are elbow telescopes of a number of designs differing in components of the optical system, method of mounting, and other details depending upon the purpose of the instrument. The specific instruments described herein are typical of those designed for different purposes.

**8-9. Typical Elbow Telescopes.**

a. The elbow telescope illustrated in figure 8-9 is typical of those designed for direct sighting in elevation as a part of a two-sight, two-man system of the howitzer. It has 3X magnification, 13° 20 minutes field of view, and has a combination reticle graduated for use with two types of ammunition. The elbow telescopes of this series are of the fixed focus type, are not provided with filters, have two reticle illuminating windows, an instrument light adapter, and are identical except for differences in reticle patterns (fig 8-9).

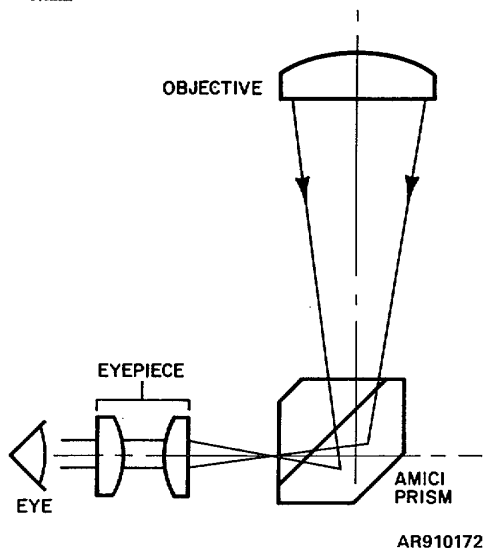

Figure 8-8. Schematic diagram of elbow telescope.

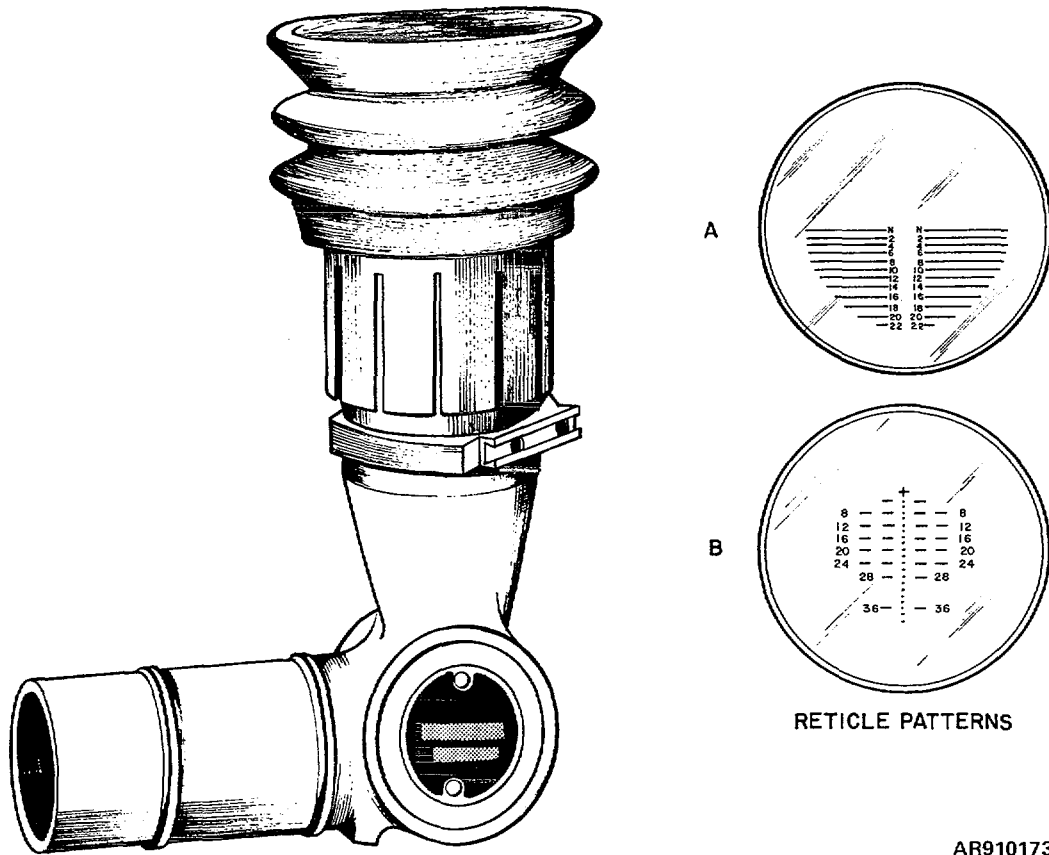
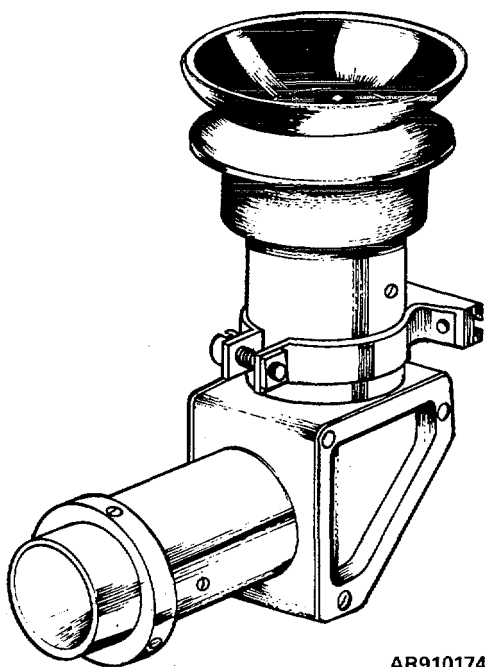

Figure 8-9. Elbow telescope (Howitzer)- assembled view, reticle patterns.

b. The elbow telescope illustrated in figure 8-10 is typical of those designed for use as a component of various sight units for pointing the weapon in azimuth and elevation for both direct and indirect fire. The reticle may be illuminated for night

operation. It has a 3X magnification and a field of view of 12° 12 minutes, a removable mounting ring, is of the fixed focus type, and is not provided with filters.



AR910174

Figure 8-10. Elbow telescope (Sight Units)-assembled view, reticle pattern.

c. The elbow telescope illustrated in figure 8-11 is the basic instrument used for laying the towed howitzer in elevation for direct fire. It is mounted and bore-sighted in a mechanism which is integral with the upper part of the elevation quadrant. The instrument is basically similar in function to other direct fire telescopes now in use except for a reticle presentation of multiple ballistic data and use of a moveable range marker than can be set to range values for direct fire. This elbow telescope has a field of view of 142 mils and a 8X magnification.

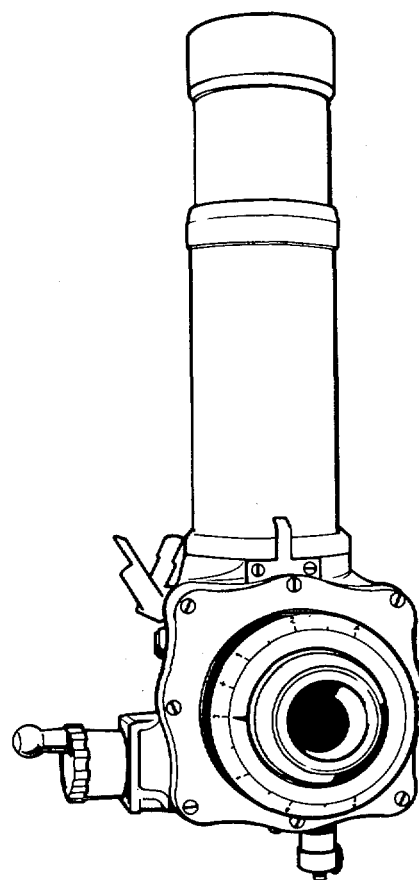

AR910175

Figure 8-11. Elbow telescope (Towed Howitzer)-assembled view.

d. The elbow telescope illustrated in figure 8-12 is the direct fire telescope used for positioning the howitzer on targets visible from the vehicle.



Controls for laying the howitzer on line-of-sight targets are the same as those utilized for indirect fire, since the telescope and mounts are bolted to the howitzer mount. Correction for cant is achieved by rotating the telescope within its mount and

thereby erecting the reticles with the aid of an illuminated cross-level. The howitzer is then elevated and the target aligned to the proper range mark on the reticle. It is a 4 power elbow-type instrument with a field of view of 10°.

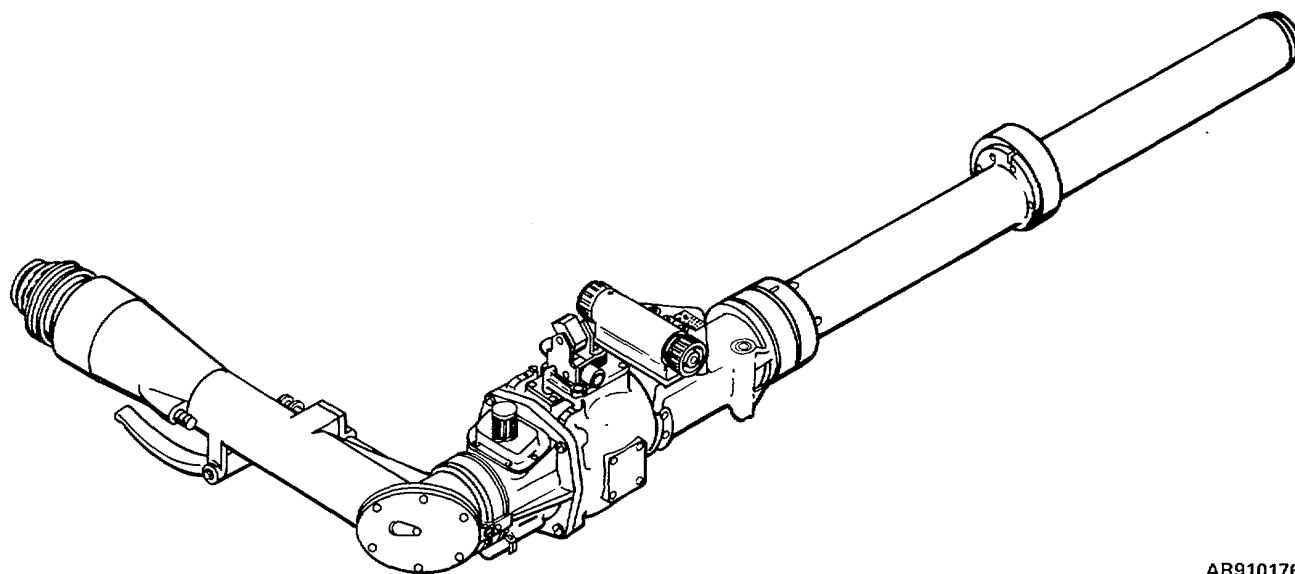

AR910176

Figure 8-12. Elbow telescope ( Self Propelled Howitzer)- assembled view.

#### Section IV. PANORAMIC TELESCOPES

##### 8-10. General.

a. The panoramic telescope is a type of fire-control instrument employed to aim a gun or howitzer in azimuth. It is used in conjunction with a telescope mount to which it is assembled. The telescope mount travels in azimuth with the weapon, carrying the line of sight of the telescope: The telescope provides the mechanisms for setting the azimuth angle while other associated equipment supplies the elevation angle of site (vertical, angle.).

b. The characteristic feature of the panoramic telescope is that it maintains an upright image regardless of whether the line of sight is directed forward, to the side, or to the rear of the observer (para 4-7d (4) and (5)). The upper or rotating head of the instrument and the line of sight may be rotated 360° or through any desired angle in the horizontal plane without requiring the observer to change his position. The mount provides for the

raising or lowering of the line of sight to any required angle. By the combination of these motions, the line of sight can be directed on any aiming point.

c. The different types and models of panoramic telescopes are of the same basic design. They differ in the components of their optical systems, the angle at which the eyepiece is mounted with relation to the upright body of the instrument, the indexing of the scales, provisions for setting in deflection, method of mounting, reticle patterns, manner of adjustment, lighting, and other details. A number of these differences are determined by the characteristics of the materiel with which the instrument is used.

d. An objective prism, a rotating Dove prism, and an Amici prism (fig 8-13) comprise the erecting system of the great majority of panoramic telescopes. A Pechan erecting prism assembly may be used in place of the rotating Dove prism.

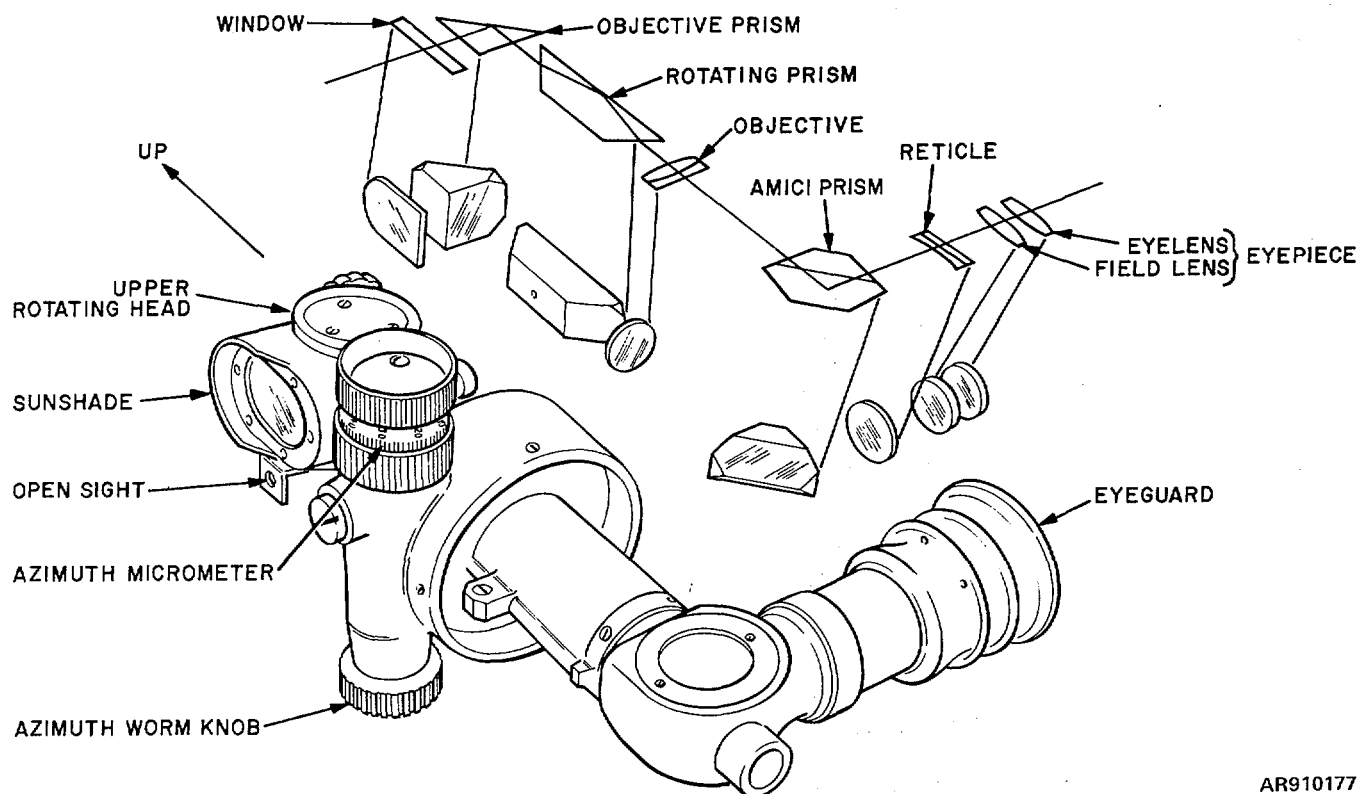

AR910177

Figure 8-13. Panoramic telescope (towed Howitzer) - assembled view, optical elements, and optical diagram.

### 8-11. Panoramic Telescope (Towed Howitzer).

a. The panoramic telescope illustrated in figure 8-13 is typical of those designed for use on a telescope mount primarily to point a gun or howitzer in azimuth for indirect fire and may also be used for direct fire. It has a magnification of 4 power and a field of view of 10°. An azimuth scale and micrometer are provided for setting deflections. A throwout lever permits rapid traversing without the use of the azimuth knob. The 900 objective prism in the head of the telescope may be rotated in elevation a limited amount, if necessary, to bring the aiming point into the field of view.

b. The erecting system is comprised of an objective prism, rotating Dove prism, and Amici prism (figs 4-11 and 4-22). A plane glass window in the rotating head protects the optical system from dirt, dust, and other foreign matter; it particularly protects the objective prism from scratches and breakage. A compound objective is mounted between the rotating prism and the Amici prism. The eyepiece is of the Kellner type with an achromatized doublet field lens and

double-convex eyelens. A reticle with appropriate pattern for the type of materiel used is mounted in the focal plane of the objective between the Amici prism and the eyepiece. The model designation of the telescope indicates the reticle pattern. The reticle is illuminated by a lighting system for night use. An open sight on the side of the rotating head enables the observer speedily to pick up the designated target.

### 8-12. Panoramic Telescope (Self-Propelled Howitzer).

a. The panoramic telescope illustrated in figure 8-14 is the basic instrument used in laying the weapon in azimuth and is mounted directly on the telescope mount. It is a 4 power, fixed-focus telescope with a 170 mil field of view. It is equipped with a mechanical counter device and a gunner's aid counter is integral with the instrument. Included also is a reset counter which can be set to show a reading 3,200 mils when the telescope is aligned with the aiming stakes and the weapon is parallel to the base line. A gunner's aid counter mechanism, which permits azimuth

corrections for factors peculiar to the individual weapon and its emplacement, can be entered easily into the instrument and is an integral part of the counter mechanism.

b. The 90° head prism, objective lens, reticle and erector lens are included in a single assembly which permits no relative movement between the reticle and the head 90° prism as the cab traverses in azimuth.

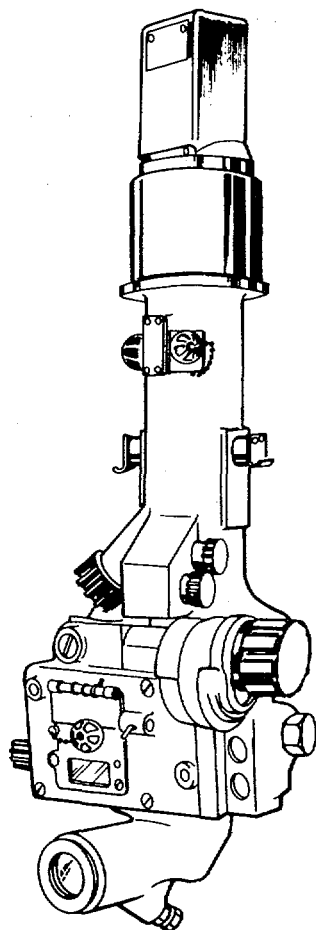

AR910178

Figure 8-14. Panoramic telescope (Self Propelled Howitzer)- assembled view.

**8-13. General.**

a. The basic purpose of the periscope is to raise the line of vision in order that targets may be seen from entrenchments, or from behind obstructions, or out of enclosed vehicles. The principle of

**Section V. PERISCOPES**

operation of the periscope is that double reflection of light from two paralleled mirrors, each placed at a 45° angle and with their reflecting surfaces facing each other (fig 8-15), forms a normal erect image of the object.

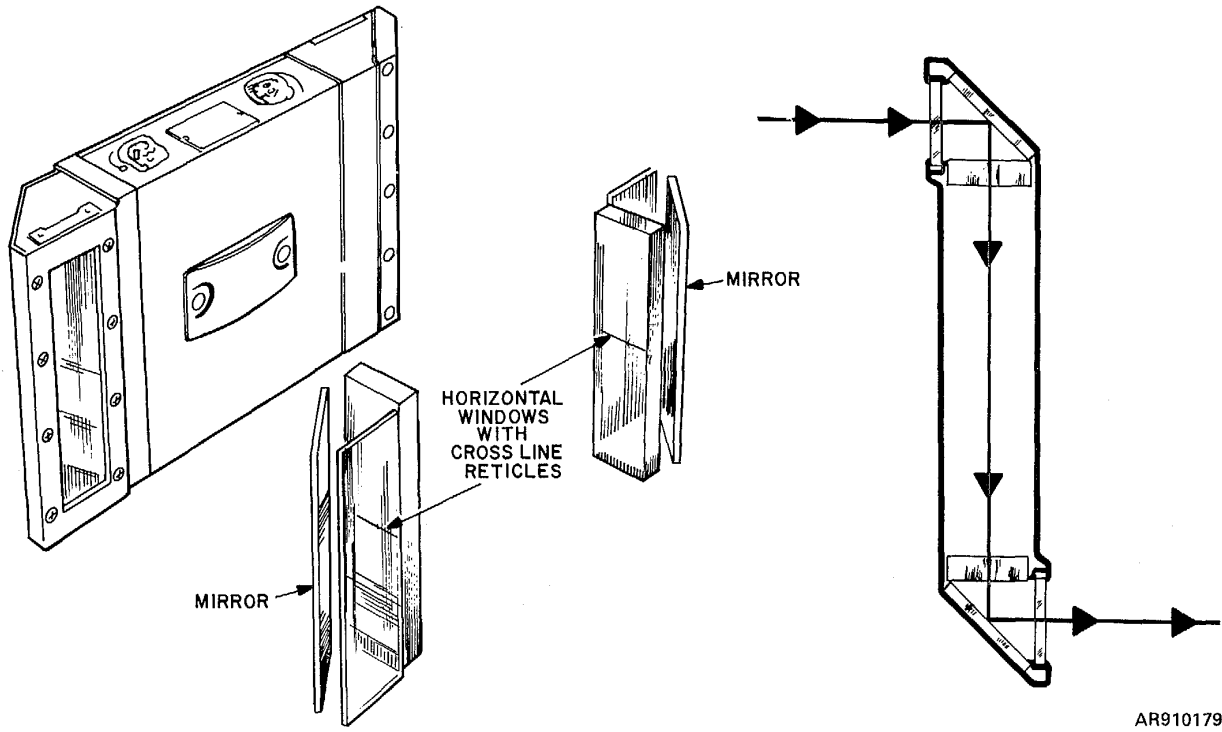
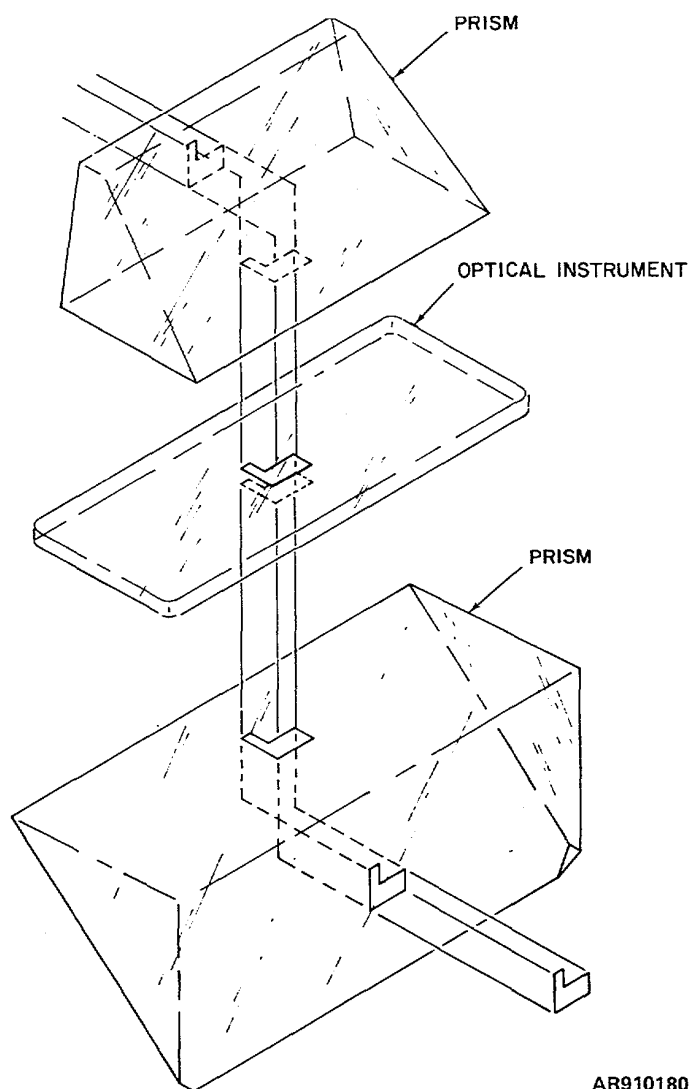

Figure 8-15. Periscope (Tank Observation)- assembled view, optical elements, and diagram of principle of operation.

b. Solid 90° glass prisms can be used instead of plane mirrors (fig 8-16 to reflect the light through

an angle of 90° twice and to displace the line of vision vertically.



AR910180

Figure 8-16. Optical diagram and optical elements of periscope.

#### 8-14. Periscope (Tank Observation).

a. The periscope illustrated in figure 8-15 is typical of those designed for use as an observation instrument, to view outside objects from the inside of a tank. It has a rectangular body with a removable top or head and a removable bottom or elbow. The top surface of the head and the bottom surface of the elbow slant at the same 45° angle. Clamps attached to the head and elbow engage latches operated by eccentric assemblies in the periscope body. They hold the head and elbow firmly on the body yet permit ready removal. Plastic material is used in the construction of the head to permit it to shatter into small fragments

when struck by a projectile and not jam or injure the periscope body. Spare heads are furnished for a replacement. When the periscope is in place, only the head projects through the tank.

b. The optical system (fig 8-15) consists of two plane mirrors, two vertical windows, and two horizontal windows. The mirrors are mounted at 45° angles, parallel to and facing each other. One mirror is mounted in the head, the other in the elbow. The vertical windows are mounted in the front of the head and in the rear of the elbow. The horizontal windows, of thicker glass, are mounted in the bottom of the head and in the top of the elbow. Gaskets around the edges of the

windows provide a seal against the entrance of dust and moisture. Crosslines are etched on the horizontal windows for rough sighting in observation.

c. The periscope is supported in either a viewing or a retracted position in a periscope holder which is secured to the body of the vehicle. The holder permits rotation of the periscope in elevation and azimuth.

d. This periscope is 11 inches long, 6 1/2 inches wide, 3-1/8 inches in thickness, and has an offset of 8-7/8 inches.

**8-15. Periscope (Self-Propelled Vehicle).**

a. The periscope illustrated in figure 8-17 is a unity-power daylight viewing device employed by the driver of the vehicle. Three periscope stations are provided within a notable armored hatch which afford the driver the maximum of safety and vision of the terrain during tactical maneuvers.

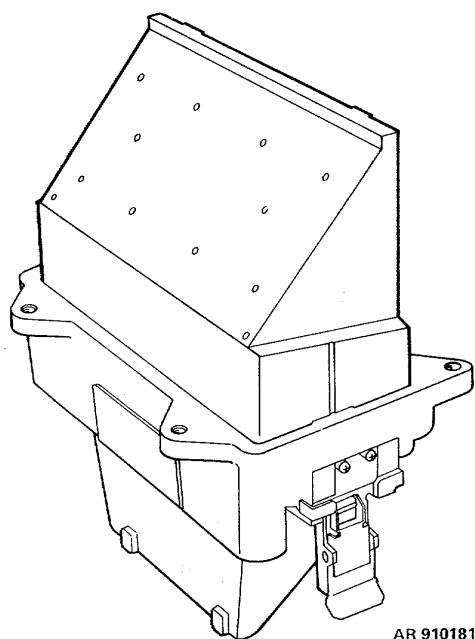

AR 910181

Figure 8-17. Periscope (Self-Propelled Vehicle) assembled view.

b. Each periscope consists of two separate units, a head assembly and a body assembly. Both are coupled together by a common mount.

c. Two 90° prisms and an optical instrument window (fig 8-16) comprise the optical components of this periscope.

d. The head assembly contains a 90° prism for directing the forward line of sight through the window of the body assembly. The body assembly contains the aforementioned window and another 90° prism that displays the field of view to the driver. This periscope provides a 500 horizontal and 140 vertical field of view.

**8-16. Periscope (Tank).**

a. The periscope illustrated in figure 8-18 is a monocular-type optical sighting instrument that serves as the main component in the fire control system of the machinegun on the tank.

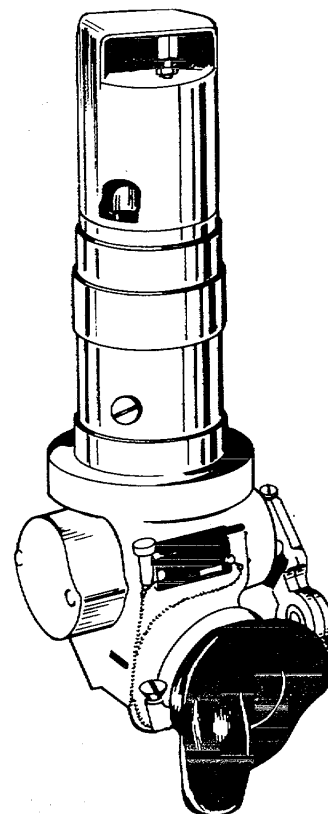

AR 910182

Figure 8-18. Periscope (Tank)- assembled view

b. The eyepiece of the periscope, which contains the eyelens, center lens and field lens (fig 8-19) is fixed and remains stationary relative to the vehicle. The prism rotates the line of sight from 15° depression to 60° elevation in maintaining the line of sight parallel to the line of fire of the machinegun throughout the gun's full range. Connection from the gun to the periscope is made

through a quick-release sight link assembly, movement of which is transmitted to the prism through tape-connected pulleys. The sight link

assembly is not part of the tank periscope, but is issued as equipment with the periscope.

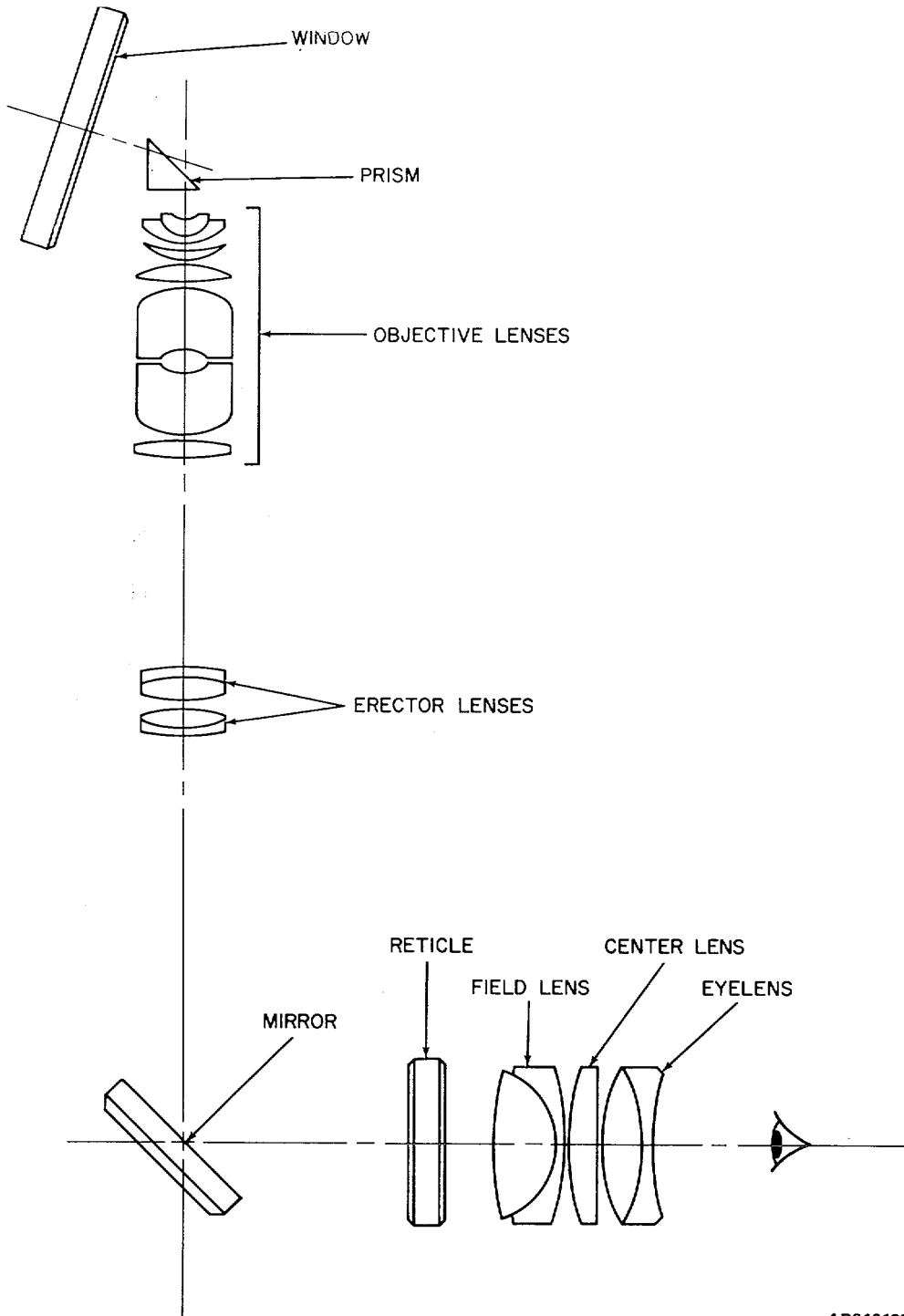

AR910183

Figure 8-19. Periscope (Tank) - diagram of optical system.

c. Means for making azimuth boresighting adjustment is provided by azimuth adjustment pin at the mounting flange of the sight. Elevation adjustment is provided at the connecting arm to which the sight link assembly connects. A rubber eyeshield, mounted over the periscope's eyepiece, serves to protect the eyelens and prevent injury to the machinegunner.

#### 8-17. Periscope (Infrared).

a. The periscope illustrated in figure 8-20 is an infrared viewing device of the binocular type used in night driving of vehicles. Invisible infrared rays are projected forward from headlamps at the bow of the vehicle to "illuminate" the field of view. The periscope converts the infrared image to a visible image which is viewed through conventional eyelenses. For best vision at average speeds the range of the periscope is focused at 18 yards.

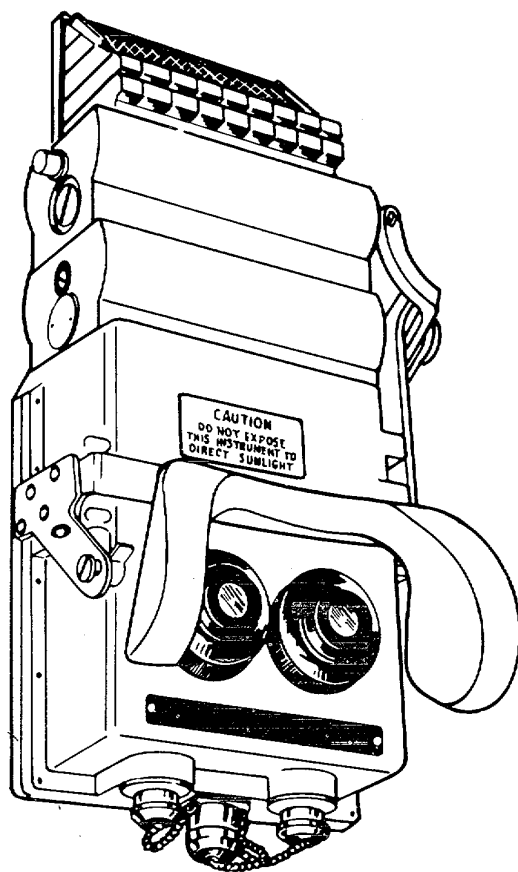

AR 910184

Figure 8-20. Periscope ( Infrared) - assembled view.

b. This periscope has a magnification of 1 power, a field of view of  $26.8^{\circ}$  and a focal point of 18 to 20 yards.



**Section VI. BINOCULARS****8-18. General.**

a. A military binocular or field glass consists of two terrestrial prism offset-type telescopes pivoted about a hinge which provides adjustment for interpupillary distance for use with both eyes. The left telescope of many models contains a reticle (H and I, fig 4-25). An erecting system is required in each of the halves of the instrument; prisms are used as erectors to increase stereoscopic

vision and to provide a compact instrument (fig 8-21). The optical axis of each scope must be parallel to the hinge throughout the entire movement of the interpupillary range; otherwise each eye will see a different field resulting in a double image, if deviation is great, and headache will result from eyestrain in bringing the two fields into coincidence.

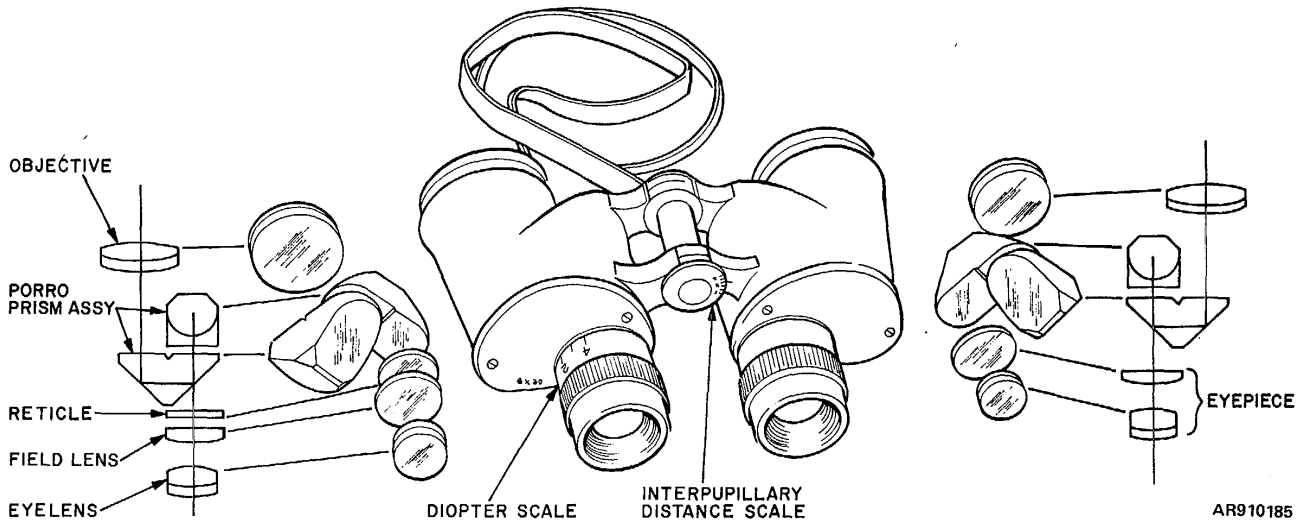

Figure 8-21. Binocular (General Use)- assembled view, optical elements, and optical diagram.

b. The power or magnification of the binocular, like that of the monocular telescope, depends upon the focal lengths of the objective and eyepiece groups. The true field of view depends upon the design of the lenses and the power. The brightness of image depends upon the size of the objective. The amount of the exit pupil that can be used depends upon the size of the pupil of the eye of the observer which varies from about 2 millimeters for very brilliant illumination to about 4 or 5 millimeters in daytime, and about 8 millimeters for very faint illumination. The design of an instrument of this type determines its suitability for a specific purpose. A binocular with large objectives and exit pupils is generally better suited for observation at night and other conditions of poor visibility. A binocular of this type is often referred to as a "night glass."

c. Binoculars usually are designated by the power of magnification and the diameter of the objectives. Thus, a 6 x 30 binocular magnifies 6 diameters and has objectives which are 30 millimeters in diameter. This designation usually is stamped on the instrument.

d. Binoculars permit the use of and increase the radius of stereoscopic vision. The observer views the object from the two objectives which are more widely separated than his eyes, while the magnification provided by the instrument increases his range of vision. For example, if the distance between the lines of sight of his eyes is doubled by the use of prism binoculars and a 6-power instrument is used, the radius of stereovision is increased from a normal of approximately 500 meters to approximately 6,000 meters (500 meters times 2 times 6).

e. The binocular hinge is equipped with a scale which indicates in millimeters the interpupillary distance (distance between the pupils of the eyes). When the proper setting for the observer has been determined, any binocular may be adjusted at once for the correct interpupillary distance.

f. All of the binoculars covered in this manual are constructed for separate focusing; that is, each

eyepiece can be focused independently of the other by turning the diopter scale in a plus or minus direction. The scale, which is calibrated in diopters, indicates the correction required for the corresponding eye. Once the proper setting for diopter adjustment has been determined for each eye, the setting may be applied immediately on future use.

#### **8-19. Binocular (General Use).**

a. The binocular illustrated in figure 8-21 is typical of those designed for use as a general purpose instrument by all services for observation and approximate measurement of small angles. It has a magnification of 6 power, the objective diameter is 30 millimeters, and the field of view is 80 30 minutes. Each of the prism offset-type telescopes has an achromatic objective and a Kellner-type eyepiece with a compound eyelens and a plano-convex field lens. A porro prism erecting system is employed in each telescope. The eyepieces are individually adjustable from plus 4 to minus 4 diopters to meet eyesight variations. Graduated diopter scales permit refocusing of both eyepieces. The interpupillary distance adjustment also is provided with graduations to permit presetting.

b. A reticle is included in the optical system for the left eye (I, fig 4-25). The binocular is equipped with a filter and a carrying strap. This model has improved waterproofing.

#### **8-20. Battery Commander's Periscope.**

a. The battery commander's periscope illustrated in figure 8-22 is a binocular instrument which consists of two periscope-type telescopes joined at the top by a hinge mechanism, to permit adjustment of the distance between the eyepieces. The eyepiece being about 12 inches below the line of sight. The BC periscope is not hinged at the bottom (as were earlier model BC's periscopes) and is typical of those designed to be used only for periscopic observation, with the telescopes in a vertical position.

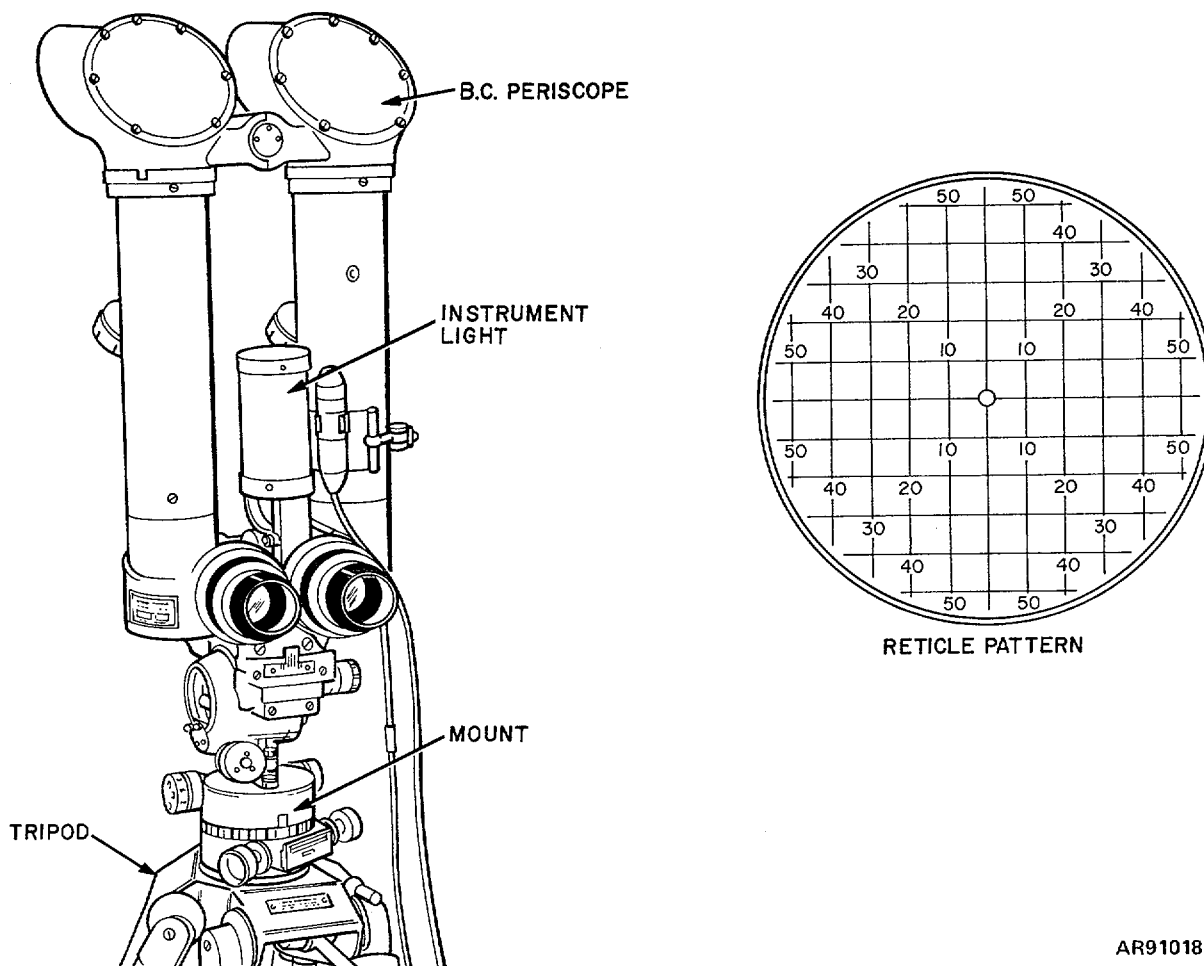

Figure 8-22. Battery commander's periscope - assembled view, reticle pattern.

b. The BC periscope employs 90° prisms at the top with their mates at the bottom to complete a Porro prism erecting system (para 4-5c) (thus eliminating the lens erecting system) and also to effect a vertical displacement of the line of sight.

c. The instrument has a magnification of 10 power and a field of view of 60. It is used for observation and for measuring angles. The right telescope contains a reticle, calibrated in mils (1/6400 part of a circle), for measuring angles in

elevation and azimuth. One lamp provides illumination for the reticle. Another lamp, on a flexible cable, is used as a hand light to read the instrument scales and micrometers.

d. Each periscope is provided with filters; amber, red, neutral (smoke), or a clear window may be moved into position between the objective lens and eyepiece of either telescope.

### Section VII. RANGE FINDERS

#### 8-21. General.

a. The range finder is essentially two periscopic telescopes or sights (either with one eyepiece or two) with two lines of sight through prisms or reflectors at ends converging on the target. The

angle of convergence is indicative of the range. The compensator lenses (27 and 28, fig 8-23) provide angular deviation of the right line of sight for ranging.

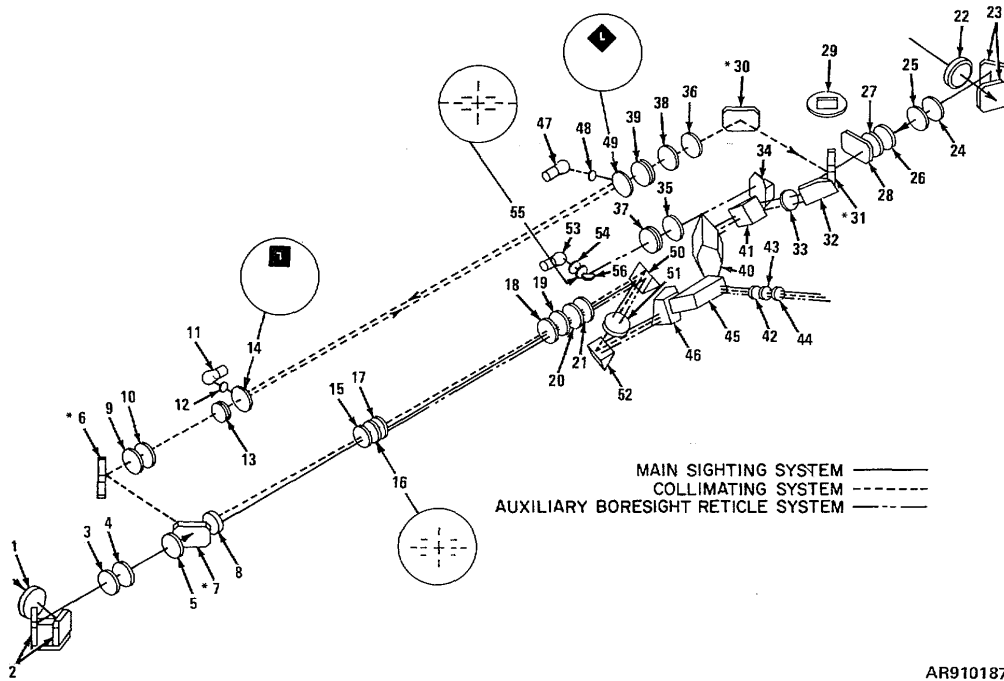

AR910187

**\*PART OF BONDED PORRO REFLECTOR ASSEMBLY**

**LEFT END HOUSING ASSEMBLY OPTICAL COMPONENTS**

- 1. End housing window
- 2. End housing penta reflector
- 3. End housing correction wedge
- 4. Range finder end window
- 5. Filter
- 6. Porro reflector (part of bonded porro reflector assembly)
- 7. Porro reflector (part of bonded porro reflector assembly)
- 8. Objective lens
- 9. Corrective wedge
- 10. Corrective wedge
- 11. Right reticle lamp

- 12. Right coincidence reticle window
- 13. Collimator lens
- 14. Right coincidence reticle
- 15. First collective lens
- 16. Main boresight (gunlaying) reticle
- 17. Second collective lens
- 18. First erector lens
- 19. Correction wedge
- 20. Correction wedge
- 21. Correction wedge.

**RIGHT END HOUSING ASSEMBLY OPTICAL COMPONENTS**

- 22. End housing window
- 23. End housing penta reflector
- 24. End housing correction wedge

**RIGHT MAIN HOUSING ASSEMBLY OPTICAL COMPONENTS**

- 25. Range finder end window
- 26. Filter
- 27. Compensator lens
- 28. Compensator lens
- 29. Range scale prism
- 30. Porro reflector (part of bonded porro reflector assembly)
- 31. Porro reflector (part of bonded porro reflector assembly)
- 32. Prism
- 33. Objective lens
- 34. Porro prism
- 35. Reticle lens
- 36. ICS wedge
- 37. Reticle lens
- 38. Correction wedge
- 39. Collimator lens
- 40. Right ocular prism
- 41. Beam splitter prism
- 42. Eyepiece field stop
- 43. Field lens
- 44. Eye lens
- 45. Combining prism
- 46. Left ocular prism
- 47. Left reticle lamp
- 48. Left coincidence reticle window
- 49. Left coincidence reticle
- 50. First 90-degree prism
- 51. Second erector lens
- 52. Second 90-degree prism
- 53. Reticle lamp
- 54. Diffusion disk
- 55. Auxiliary boresight (gunlaying) reticle
- 56. Reticle mirror

Figure 8-23. Optical system schematic.

b. The purpose of a range finder is to find the range of an object or target. This instrument measures distance by triangulation.

c. The range finder contains two optical systems which permit a single observer to view the target from points some distance apart. This distance serves as the known leg of the triangle. It is termed the base line (fig 8-24) and is one form of designation of a range finder, that is, a 1-meter base instrument. One of the two angles from which the target is observed is fixed at 90°; the other

angle is variable, depending upon the distance of the target from the instrument. The angle to which the 90° and the variable angle converge is termed the parallax angle. It becomes larger as the distance to the observed object becomes less. Because of the extreme shortness of the base line in comparison with the range to be computed, the utmost accuracy and precision are required in the determination of the angles at the two ends of the base line.

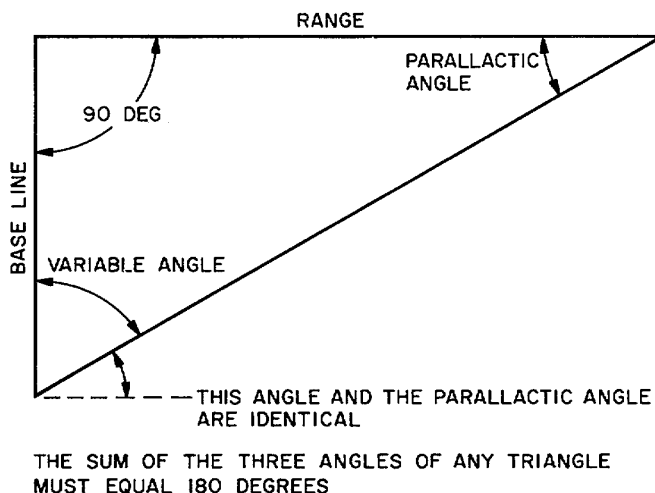

AR910188

Figure 8-24. Fundamental triangle of range finder.

d. In the stereoscopic range finder, by turning the range knob, the target is made to appear in the same distance plane as the central measuring mark (pip) of the stereo reticle, when "stereoscopic contact" is established.

e. In the coincidence range finder, the two optical systems are focused into a single eyepiece assembly. When the range knob is rotated, the left and right fields of view are superimposed and "coincidence" of the two images of the selected target is established.

f. A very simple and practical type of stereoscopic range finder, based on still another principle, consists of a binocular telescope having a scale in each ocular. The two scales will fuse into a single scale, in relief, having the appearance of a row of dots receding to infinity. These dots are seen alongside the scene observed and every object in the scene appears to be located in the same plane as one of the dots. Distance to rapidly moving objects can be determined approximately very quickly by this method, while a slower

method could not be used to advantage with a very rapidly moving target.

**8-22. Range Finder, Tank (Typical Coincidence Type).**

a. General. The range finder illustrated in figure 8-25 is typical of the coincidence-type instruments designed for use as the principal ranging device in the primary sighting system of tanks, and is used for direct fire operation. This range finder is designed to provide automatic and continuous ranging information through an output shaft to the ballistic computer. For sighting systems that do not include a ballistic computer, range information may be read from the range scale. Accuracy of the range finder is inherently high because of its long base length, 79 in., and 10-power magnification. The range finder may also be used, if the gunner's periscope is out of commission, for boresighting the gun. Either the left or right end of the range finder may be used for boresighting.

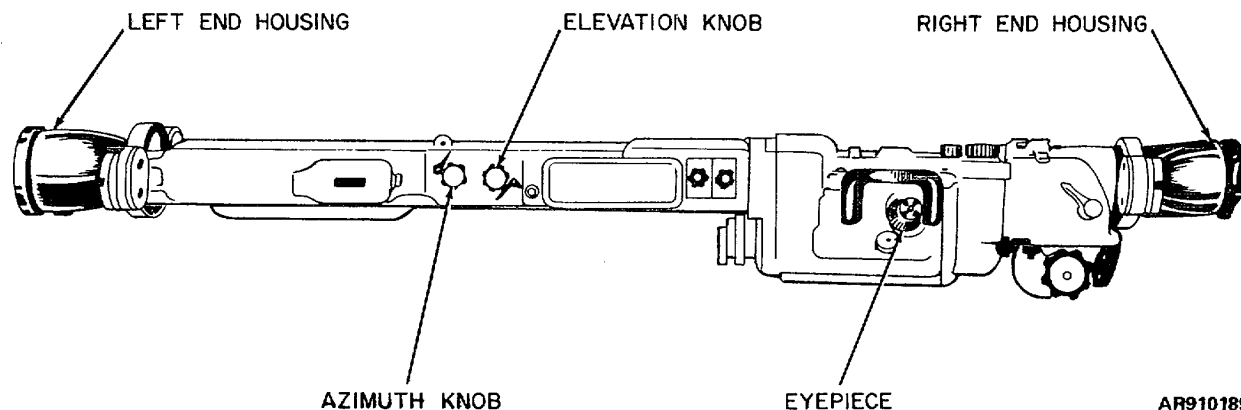

Figure 8-25. Range finder , tank (typical coincidence type).

b. Characteristics. This typical coincidence-type range finder measures 85 x 14 x 12 inches overall, weighs 149 pounds including end housing assemblies, has a range of 500 to 4400 meters, and a field of view of 4°.

**NOTE**

The key letters shown in parenthesis in c and d below, refer to figure 8-23.

c. *Theory of Operation.*

(1) Light from a target enters the range finder through the right and left end housings. There is a definite parallax (convergent) angle between the light entering through one end housing window from the target and light entering through the other end housing window from the target. This parallax angle varies with target distance, being larger for close targets than for distant targets. The optical system (fig 8-23i) utilizes this parallax angle variation as a means of measuring target range. This is accomplished by displacing a specially designed lens a calibrated distance in order to deviate the light through the parallax angle and establish coincidence of the target at the eyepiece.

(2) Light rays, upon entering each housing window, are reflected 90 degrees toward the center of the range finder. These light rays enter the telescope optical systems and, after passing through the lenses and being reflected by the prisms, leave the instrument by way of the single eyepiece. Light rays from the internal collimator optical system are projected to the telescope optical systems by means of reflectors. Images formed at the eyepiece diaphragm are a composite of a target image and the image of the internal collimator optical system coincidence reticles for both the right and left side optical systems.

d. *Functional Description.*

(1) *General.* For purposes of description, the left optical system, the right optical system, reticle

patterns, and reticle illumination system of the range finder are treated separately. Component parts of each system are individually described to define their functional purpose.

**NOTE**

The key numbers shown in parentheses refer to figure 8-23.

(2) *Left optical system.* The left optical system consists of an end housing assembly, a main sighting system, and a collimating system. A target image picked up at the end housing assembly is transmitted into the main sighting system. A coincidence reticle image projected from the collimating system is also projected in this main sighting system. These images merge with the gunlaying reticle and are transmitted to the eyepiece which is common to both the left and right optical systems.

(a) *End housing assembly.* The target image is picked up by the end housing assembly and turned 90 degrees for introduction into the left main sighting system.

1. The end housing window (1) is a plano plate, that seals the end housing against dirt and moisture.

2. The end housing penta reflector (2) provides a constant deviation of 90 degrees. The penta reflector is adjustable to correct for tilt and deviation.

3. The end housing corrections wedge (3) on the inboard end of the housing may be used to correct deviation due to initial misalignment of the penta reflector or housing. The wedge also serves as a window, which seals the end housing against dirt and moisture.

4. The end face of the housing casting is precision machined. Alignment keys are used to position the end housings to the main housings.

(b) *Left main sighting system.* The left main sighting system carries the target image from

the left end housing assembly to the eyepiece. The left main sighting system is housed in both left and right main housing castings.

1. The range finder end window (4) is a plano plate, which seals the left sighting system against dirt and moisture.

2. The filter (5) increases contrast between the target image and the illuminated coincidence reticle (49). A matched filter (26) for the right main sighting system is engaged simultaneously with the left filter by a control lever on the right main housing.

3. A porro reflector assembly (6) and (7) consisting of a partial reflector (7) and a full reflector (6) bends the coincidence reticle image 180 degrees to superimpose it on the target image. The partial reflector, in the line of sight of the main sighting system, picks up the coincidence reticle image from the full reflector, which picks up the image from the left collimating system. The path of the target image is not affected by the partial reflector. Approximately 65 percent of the incoming field light is transmitted through the partial reflector, 30 percent is lost by reflection and 5 percent is lost by absorption. Less than 30 percent of the light from the collimating system is transmitted into the line of sight; 70 percent of the light passes through the partial reflector and is lost. However, collimator light intensity can be varied by a rheostat.

4. The left objective lens (8) receives light from the target and coincidence reticle, and provides a focus adjustment. Light rays from the left objective lens (8) are converged upon the first collective lens (15) and are brought into focus at the main boresight (gunlaying) reticle (16). Moving the collective lens adjusts the focal length to the desired angular values of the reticle calibrations. The left objective lens and the first collective lens function together as a single lens.

5. The main boresight reticle assembly contains the main boresight (gunlaying) reticle (16). Because it is in the focal plane of the objective lens (8) and the first collective lens (15), this reticle is superimposed on the target image. Control knobs move the boresight reticle vertically and horizontally to align it with the target image for boresighting, range estimation, or both. The main boresight reticle assembly has a collective lens (15 and 17) on each side of the reticle (16) to increase the field or peripheral light.

6. A composite image of the reticles and target, formed by the second collective lens (17), is located at the focal plane of the first erector lens (18).

7. The target and reticle images are positioned vertically and horizontally by a series of

three correction wedges (19, 20, and 21). The vertical calibration mechanism optical components consist of two correction wedges (19 and 20). A gear located between the two wedges causes these wedges to rotate in opposite directions. Light rays entering the first correction wedge (19) are bent towards the thickest part of this wedge. Due to the relationship of the thick sections, a vertical vector resultant is formed which optically raises or lowers the light rays. The horizontal calibration mechanism consists of a single correction wedge (21). This correction wedge receives the light rays from the second correction wedge (20) of the vertical calibration mechanism. As the horizontal wedge is rotated, light rays are deviated in a horizontal direction.

8. The first 90-degree prism (50) reflects the target and reticle images into the second erector lens (51).

9. The second erector lens is used to set the focus during the assembly of the range finder, and to bring the focal plane of the left main sighting system to the eyepiece field stop (42).

10. The second 90-degree prism (52) bends the light rays into the left ocular prism (46).

11. The left ocular prism (46) is a penta prism that reflects the target image 90 degrees into the combining prism (45).

12. This combining prism displaces the light rays parallel to itself. The light rays are then reflected into the eyepiece assembly by the rhomboidal prism component of the combining prism.

(c) *Eyepiece assembly.* The eyepiece contains a field stop and an eyepiece assembly. The field stop (42) is a diaphragm for the eyepiece assembly. It restricts extraneous or stray light for a sharp circular field of view. The eyepiece assembly has a field lens (43) and an eye lens (44), which together magnify the image.

(d) *Left collimating system.* The left collimating system projects the left coincidence reticle into the left main sighting system so that the coincidence reticle appears in the field of view.

1. The left coincidence reticle (49) is illuminated and projected into the collimator lens (13).

2. The collimator lens (13) gathers the diverging light from the reticle assembly and directs it, with the coincidence reticle image, into the porro reflector assembly (6 and 7).

3. The collimator assembly contains two correction wedge cell assemblies, each containing a wedge (9 and 10) that aligns the coincidence reticle in deflection and elevation so that it is projected in an exact relationship to the target image as seen in the main sighting system.



(3) **Right Optical System.** The right optical system consists of an end housing assembly, a main sighting system, and a collimating system. A target image picked up at the end housing assembly is transmitted into the main sighting system. A coincidence reticle (14), projected from the collimating system, is also projected in this main sighting system. An auxiliary gunlaying reticle is located in this system, and, if illuminated, is projected into the main sighting system. These images are transmitted to the eyepiece which is common to the left and right optical systems.

(a) **End housing assembly.** The end housing assembly for the right optical system is identical to that for the left optical system in (2) (a) above.

(b) **Right main sighting system.** The right main sighting system carries the target image from the right end housing assembly to the eyepiece. The right main sighting system is housed in the right main housing casting.

1. The range finder end window (25) is a plano plate and seals the right sighting system against dirt and moisture.

2. The filter (26) increases contrast between the target image and the illuminated coincidence reticle (14). A matched filter (5) for the left main sighting system is engaged simultaneously with the right filter by a control lever on the right main housing casting.

3. The compensator lenses (27 and 28) provide angular deviation for ranging.

4. The porro reflector assembly (30 and 31) in the right main sighting system is similar to that of the left main sighting system, except for the halving adjustment. The halving adjustment tilts the porro reflector to change the elevation of the coincident reticle (14) in relation to the target image.

5. The 90-degree prism (32) bends the target image into the objective lens (33).

6. The objective lens (33) converges the target image and the coincidence reticle image to a focal point at the eyepiece field stop (42) through the beam-splitter, the, right ocular,, and the combining prisms.

7. The beam-splitter prism (41) reflects the image 90 degrees into the right ocular prism (40) and superimposes the image of the auxiliary boresight reticle (55) on the target image. It also dissipates part of the light in the right main sighting system to balance the transmitted light with that in the left main sighting system.

8. The right ocular prism (40) reflects the target image into the right angle prism component of the combining prism (45). At this

point, the light combines with the reflected light from the left field of view and proceeds to the single eyepiece.

(c) **Right collimating system.** The right collimating system performs the same function as the left collimating system in (2) (d) above.

1. The right coincidence reticle (14) is illuminated and projected into the collimator lens (39).

2. The collimator lens (39) gathers the diverging light from the reticle assembly and directs it with the coincidence reticle image into the porro reflector assembly (30 and 31).

3. The ICS corrections wedge mount assembly for the right collimating system is similar to the collimator assembly for the left collimating system, except that the ICS wedge (36) for deflection correction can be rotated by the ICS knob. This moves the coincidence reticle (14) in a horizontal plane.

(d) **Auxiliary boresight (gunlaying) reticle system.** The auxiliary boresight (gunlaying) reticle system can be used for auxiliary sighting and range estimation if the left optical system becomes inoperative. It can also be used to check range finder alinement by checking its coincidence with the left main boresight reticle (16). The system consists of two assemblies: an auxiliary boresight (gunlaying) reticle bracket assembly and an auxiliary boresight (gunlaying) lens assembly.

1. The auxiliary boresight (gunlaying) reticle bracket assembly has a reticle lamp (53), a dark field cemented auxiliary boresight (gunlaying) reticle (55), and reticle mirror (56) to reflect the reticle image into the system.

2. The auxiliary boresight reticle lens assembly has two reticle lenses (35 and 37). Both reticle lenses are adjustable longitudinally along the optical axis for proper focusing of the reticle image at the eyepiece field stop. In addition, reticle lens (37) is adjustable transversely by means of the auxiliary boresight knobs to provide horizontal and vertical movement of the reticle in the field of the right optical system.

3. The porro prism (34) turns the light rays 180 degrees into the beam-splitter prism (41).

(4) **Reticle Patterns.**

(a) **General.** Four reticle patterns are used in the range finder. There is one pattern for gunlaying (A, fig 8-26), one for auxiliary gunlaying (B, fig 8-26), and two-coincidence reticle patterns (C, fig 8-26). The coincidence reticles are provided to aline the optical systems (left and right) to each other. An auxiliary reticle is projected into the right optical system in the event of damage to the left optical system.

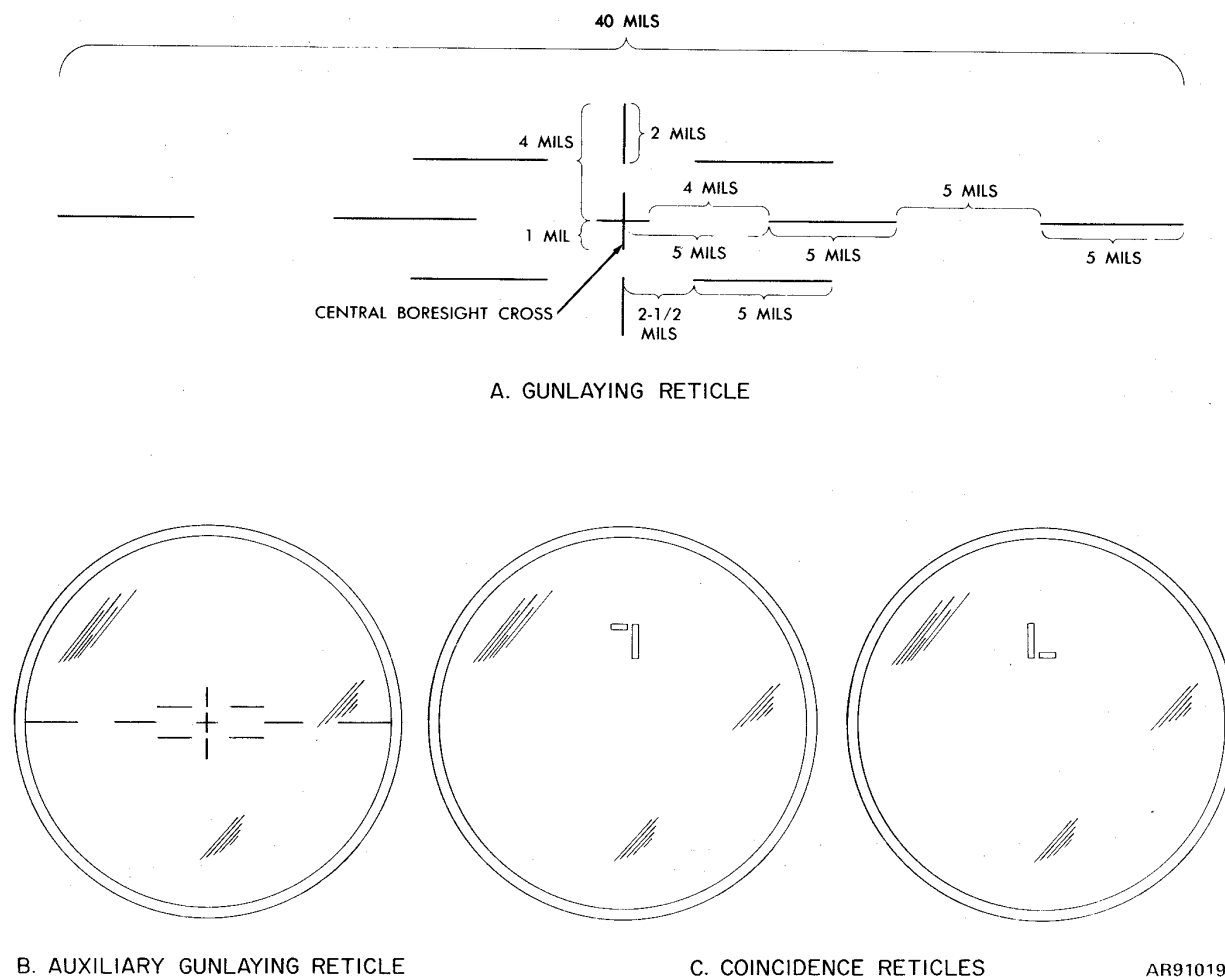

Figure 8-26. Range finder reticle patterns.

(b) *Coincidence reticle.* The right coincidence reticle (14, fig 8-23) in the right optical system is composed of a vertical line located on the vertical axis of the coincidence reticle pattern (C, fig 8-26) and a horizontal line located at the top and to the left of the vertical line. This pattern forms the lower vertical and left horizontal bars of the coincidence reticle pattern. The left coincidence reticle (49, fig 8-23) is located in the coincidence cell assembly of the right main housing. The left coincidence reticle pattern (C, fig 8-26) is formed by a vertical line located on a vertical axis of the reticle disk and a horizontal line located at the bottom and to the right of the vertical line. This

pattern forms the upper vertical and right horizontal members of the coincidence reticle pattern. The right half of the coincidence reticle is aligned with the left half of the coincidence reticle to establish a reference calibration of the instrument when the target image is brought into coincidence.

(c) *Main boresight (gunlaying) reticle.* The main boresight (gunlaying) reticle (16, fig 8-23) is located in the focal plane of the objective lens system, which results in the target image and the reticle image (B, fig 8-26) being superimposed. The aiming point of the pattern is a boresight cross, 2 mils x 2 mils, coinciding with the intersection of the vertical and horizontal geometric

axes. Two lines and two spaces, located on the horizontal axis on both sides of the boresight cross along the horizontal axis, provide a zero elevation and lead reference representing a field 40 mils in width. The spaces located immediately adjacent to each 1-mil arm of the boresight cross are 4 mils wide. Each line and space located beyond the 4-mil space represents 5 mils. Elevation and depression reference is provided by a pair of symmetrically placed broken lines of 2 mils below the center of the boresight cross. Each of these lines consist of a line, a space, and a line of 5 mils each. A 1-mil space and a 2-mil line arranged above and below the ends of the vertical member of the boresight cross on the vertical axis provide a zero reference in azimuth.

(d) *Auxiliary boresight (gunlaying) reticle.*

The auxiliary boresight (gunlaying) reticle pattern (A, fig 8-26) is identical to the main boresight (gunlaying) reticle pattern ((4) (c) above). The reticle disk for this

reticle is coated to prevent light rays from passing through the disk except at the lines of the reticle pattern.

(5) *Electrical lighting system.* A 24-volt dc electrical system provides illumination for the reticle and the range scale. A control panel on the back of the range finder provides controls for light intensity of the reticles and scales.

e. *Metric System.* Since range distances are being converted to the metric system of measurement rather than yards, future range finders will measure distance in meters.

**8-23.** Tabulated Data. The data listed in table 8-1 includes basic general characteristics of a typical range finder which are necessary to Army maintenance personnel for performing their function.

Table 8-1. General Dimensions and Leading Particulars

Technical data	Value
Length (overall).....	84 in.
Height (overall).....	12 in.
Depth (overall) .....	14 in.
Weight (including end housing assemblies) .....	149 lb
Base length.....	79 in.
Range .....	500 to 4,400 meters
Magnification.....	10 power
Field of view.....	40
Exit pupil .....	0.120 in.
Diopter scale.....	4.00 diopters

**Section VIII. SPECIALIZED MILITARY OPTICAL INSTRUMENTS**

**8-24. Collimator Sight.**

a. The collimator sight (fig 8-27) is an ingenious and relatively inexpensive type of sighting device. The collimator is inferior to the telescope in effectiveness or

convenience of operation but its simplicity, ruggedness, and low cost make it particularly desirable as a sighting device for mortars.

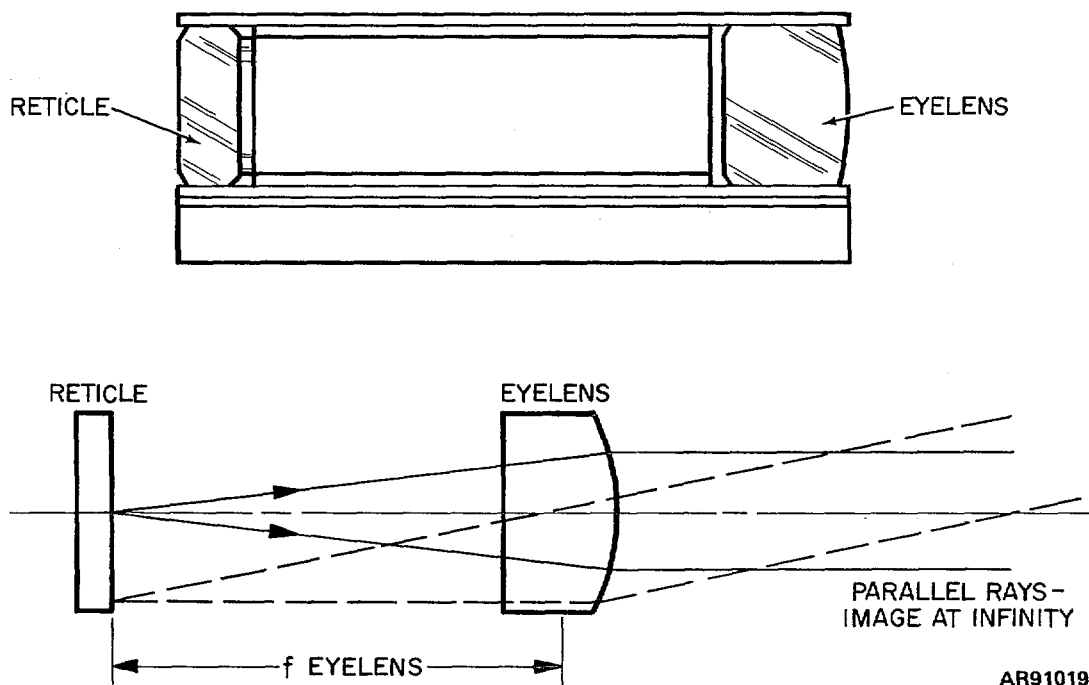

Figure 8-27. Collimator sight-optical system and optical diagram

b. The principle of the collimator is that a reticle, fairly close to the observer, can be optically transferred to a position infinitely distant from the observer. Parallax between the reticle and the target is thereby eliminated. Since there are only two optical elements, a reticle on a ground glass window and an eyelens, the entire structure can be housed in a compact tube. The eyelens is called a collimating lens because it renders rays parallel. It permits observation of the reticle at infinity or with the same eye accommodation as required to view the target. The ground glass window is covered inside with an opaque coating, excepting an uncoated center cross or vertical line, through which diffused light can enter to be viewed

through the eyelens as a cross or vertical line of light. This cross or line of light is the reticle which is placed in the principal focal plane of the eyelens for the infinity adjustment.

c. When employed as the sighting device for a weapon, the mount of the collimator is provided with leveling mechanisms and scales which permit the weapon to be placed at a prescribed elevation with relation to the line of sight established by the collimator. Sighting is accomplished by looking into the collimator and at the target simultaneously or successively to super-impose the cross or line upon the target.

**8-25. Reflector (Reflex) Sight.** A typical optical system of this kind is illustrated in figure 8-28.

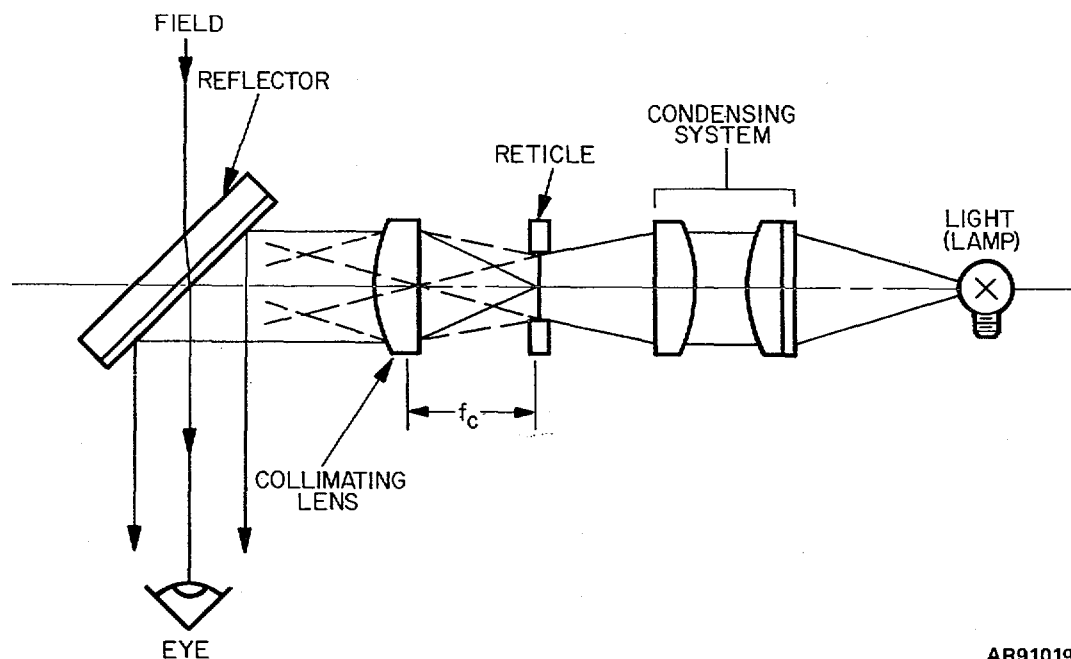

AR910195

Figure 8-28. Reflex sight.

a. Condensing Lens. Light from a lamp or reflected sunlight is concentrated on the reticle (para 4-9), usually by using a condensing lens or lens system. A frosted surface (either one surface of the condensing lens or of a plane glass plate) may be used to diffuse this light and obtain even illumination of the reticle. This light then passes through either a perforated reticle (usually punched in a metal disk) or illuminates a reticle pattern etched on glass.

b. Collimating Lens. Light from the illuminated reticle passes through a collimating lens placed one focal length from the reticle. The collimated light from the reticle is ordinarily introduced into the field of view by the use of a high-reflectance-coated glass plate which permits light to pass straight through from one side but reflects most of the light coming from the opposite direction. A half-silvered mirror may perform the same function but less efficiently.

c. Parallax. To remove parallax from this type of optical system, either the collimating lens or the reticle must be moved until the reticle pattern is clearly defined or sharply focused when viewed through the collimating telescope.

d. Operation. Since the reflected light rays from

the image of the reticle are parallel, due to the action of the collimating lens, the reticle pattern appears at infinity which makes it possible for the observer to super-impose the image on the target and focus on both at once.

e. Use. The reflex sight is a projection-type collimator sight used for direct sighting of machine guns.

#### 8-26. Aiming Circle.

a. The aiming circle (fig 8-29) is used to measure the azimuth and elevation bearing angles of a ground or aerial target with respect to a preselected base line. The aiming circle has many of the characteristics of a surveyor's transit. Basically, it consists of a telescope mounted on a mechanism which permits unlimited azimuth and limited elevation movements. By rotating two orientating knobs, zero azimuth heading with respect to magnetic north or any other selected compass heading can be established. The azimuth orienting control knobs can be disengaged for rapid movement by exerting an outward pressure on the knobs. The mechanisms are spring-loaded and will reengage when outward pressure is removed. A locking device secures the compass after the orienting adjustment, has been made.

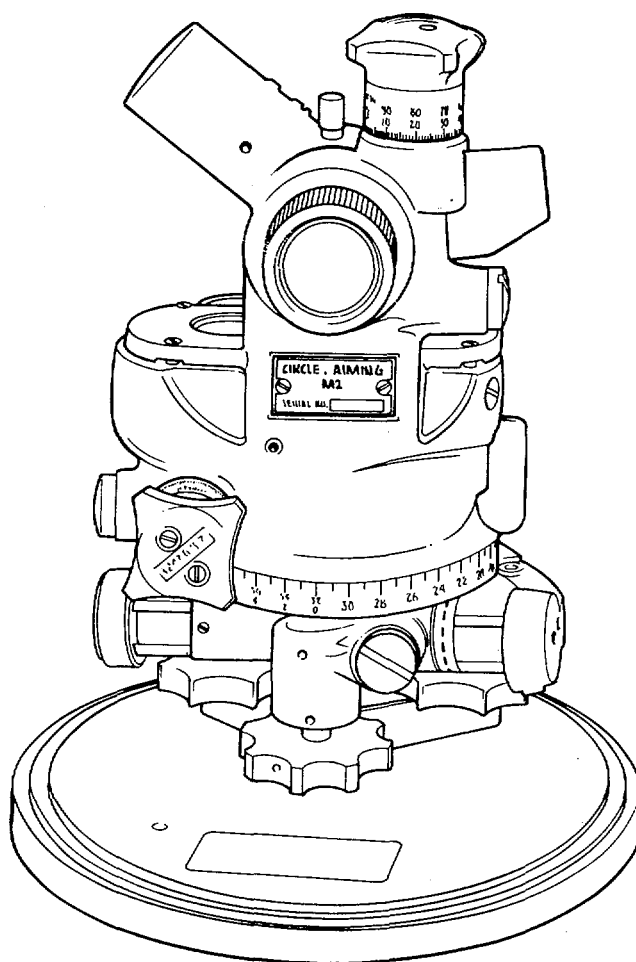

AR 910196

Figure 8-29. Aiming circle.

**8-27. Laser Range Finder.** The laser range finder shown in figure 8-30 is a laser electronic device whose function is to improve the first-round hit capability of the primary weapon. This function is

accomplished by transmitting a pulse of laser light, receiving reflecting light from the target, and converting the time from transmission to reception into range data.

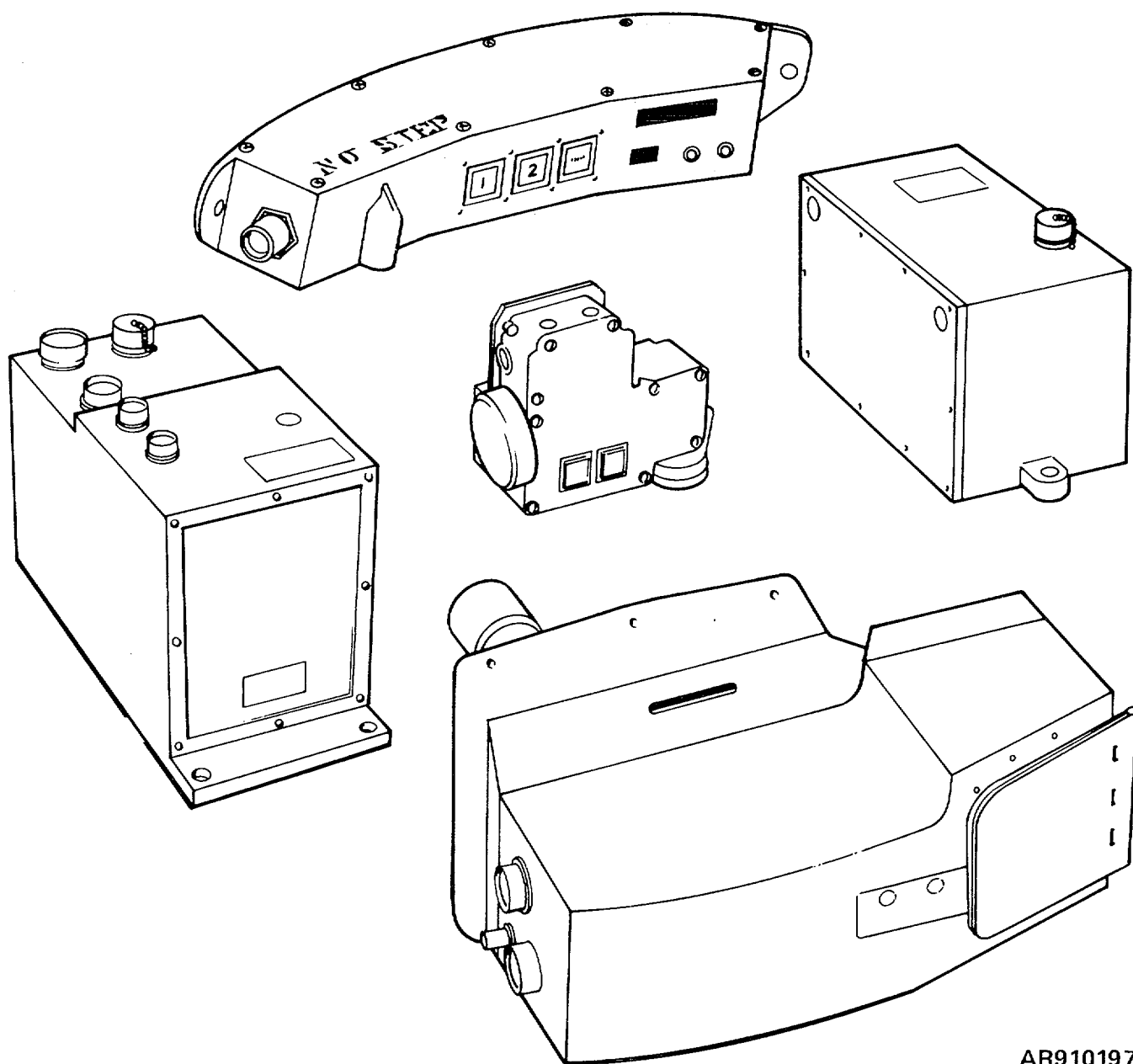

AR910197

1. Display Unit
2. Control Unit
3. Electronics Unit
4. Receive/Transmit Sight Unit
5. Auxiliary Power Supply Unit

Figure 8-30. Laser rangefinder.

**8-28. Helmet Directed Subsystem.**

a. The fire control subsystem shown in figure 8-31 is a helmet-directed sighting subsystem. This subsystem, which is helicopter mounted, interfaces

with the gun turret and the telescope sight unit of the TOW (tube-launched, optically-sighted, wire-guided) missile subsystem.

**8-31**



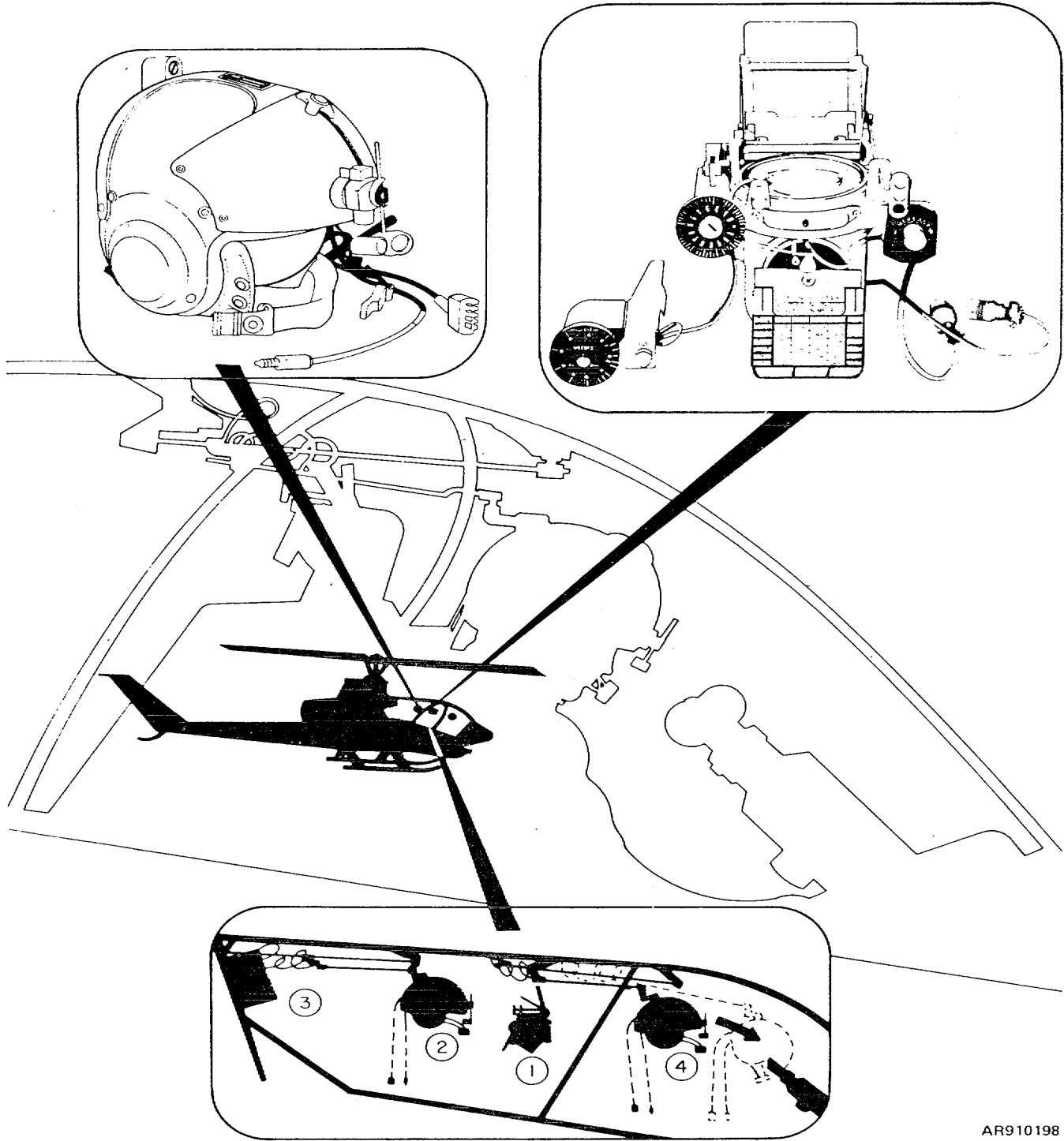

AR910198

Figure 8-31. Fire control subsystem, helmet-directed.

Legend for figure 8-31:

1. Reflex sight M73
2. Pilot helmet sight (including pilot linkage and extension cable)
3. Electronic interface
4. Gunner helmet sight including gunner linkage and extension cable)

b. The system enables the helicopter pilot and copilot/gunner to rapidly acquire visible targets and to direct either the gun turret or the sight unit to those targets. The helmet-mounted optical sight

extends over the operator's right eye, and an illuminated reticle pattern is projected into the optical sight. Electromechanical linkages sense the helmet sight lines and generate sight-line signals which are processed by the electronic interface assembly. Either operator can command the gun turret or sight unit by means of operator-select able cockpit switches. Under certain circumstances, the turret and sight unit can be commanded simultaneously, one by each operator.

## CHAPTER 9

TESTING OPTICAL PROPERTIES OF INSTRUMENTS

---

**9-1. General.** This chapter describes a number of relatively simple procedures by means of which the properties and qualities of complete instruments may be measured or calculated. For the most part, the tests can be made without special equipment. Laboratory test methods are purposely avoided.

**9-2. Objective Aperture.** The objective aperture size is limited by the clear area provided by the mount of the objective. It can be measured in millimeters or decimal parts or fractions of an inch with a scale, rule, or with a Ramsden dynameter (para 5-24).

**9-3. Measurement of Exit Pupil and Eye Distance.** Direct the instrument at an illuminated area. Focus the exit pupil (fig 2-54) on translucent paper or ground glass. To focus the exit pupil, move the paper or glass towards or away from the eyepiece until the exit pupil is seen in its smallest diameter as a sharp circular shape of even brightness. Measure the distance of the face of the paper or glass from the rear surface of the eyepiece lens with a scale graduated in millimeters or decimals or fractions of an inch (fig 2-55). Mark the opposite edges of the exit pupil on the paper or glass and measure its diameter in millimeters or decimals or fractions of an inch. The position and diameter of the exit pupil can be measured exactly by means of a Ramsden dynameter (para 5-24).

**9-4. Magnifying Power.**

a. Definition. The magnifying power of an optical instrument is the ratio of the heights of the retinal images produced in the observer's eye with and without the instrument.

b. Calculation. The magnifying power of an optical instrument depends upon the relation between the focal length of the objective and the focal length of the lenses of the eyepiece, the latter being considered as a single lens. The magnifying power of a telescope equals to the focal length of the objective divided by the focal length of the eyepiece. For example, if the objective has an equivalent focal length of 8 inches and the eyepiece has an equivalent focal length of 1 inch, the instrument will have a magnification of 8 power.

c. Measurement. The magnifying power of an instrument can be calculated when the equivalent focal lengths of the objective and the eyepiece are

known. It can be determined by measuring the focal lengths of the elements. The magnifying power can be approximately determined by this method: Mark a number of connected squares of equal size in a line on a distant white wall. Observe the squares with the right eye looking through the instrument and with the left eye looking at them naturally. The right eye will receive a magnified impression of one or two of the squares; the left eye will receive a natural impression of a number of them. The two impressions will be fused by the brain into a single impression of a large square with a number of smaller ones crossing it in a line. If four natural squares are seen inside the magnified square, the instrument has a magnification of approximately 4 diameters or 4 power.

**9-5. Measurement of Field of View.**

a. The field of view (FOV) of an instrument may be expressed in either angular or linear measure. The angular measure is more commonly given and is expressed in degrees and minutes. The linear measure is expressed in meters at ranges of 100 meters or 1,000 meters.

b. To determine angular FOV, place the telescope in a fixture or mount which is provided with an azimuth scale, a micrometer, and levels. Level the instrument and direct the telescope so that a convenient vertical object is at the left edge of the FOV. Read the scale and micrometer. Traverse the instrument until the object is at the right edge of the FOV. Again read the scale and micrometer. The difference between the two readings is the angular measure of the true FOV (para 5-25). If the scale and micrometer are graduated in mils, convert to degrees and minutes.

c. To measure the linear FOV, place two stakes at a specified distance from the instrument; one at each edge of the observed FOV. Measure the actual distance between the two stakes. The linear FOV may be determined mathematically by the formula:  $2 \times \text{tangent of one-half the angular FOV} \times \text{the range of the stakes}$ .

**9-6. Determination of Spherical Aberration.** Cut a mask of black paper that will cover the objective. Cut a circle one-half the diameter of the objective out of the center of this mask. Apply the mask to the objective. Sharply focus a distant object on the

crossline of the instrument. Now, remove the mask and place the cutout circle on the center of the objective. Examine the image of the object. Any blurring of the image may be attributed to unfocused rays in the outer zones of the objective. Adjust whatever focusing devices there are available to sharply focus the image. The amount of movement required is an indication of the amount of spherical aberration present.

**9-7. Determination of Curvature of Image.**

Sharply focus the instrument on a point in the center of the image and note whether or not the points at the edge of the image are clear and well defined. If the edges of the image are hazy, continue focusing the instrument until the edges of the image are sharp and distinct. The amount of focusing required is an indication of the curvature of image.

## CHAPTER 10

## MEASUREMENT SYSTEMS EMPLOYED IN OPTICS

**10-1. Candlepower and Foot Candles.**

a. The intensity of illumination on a surface depends upon the brightness of the light source and the distance of the surface from the light source. The brightness of any light source is measured in units of candlepower. One candlepower is the rate at which a standard candle emits light. A standard candle was initially a sperm whale oil candle, 7/8 inch in diameter, which burned at the uniform rate of 120 grains per hour. Current standards of candlepower are electric lamps which may be obtained from the Bureau of Standards.

b. The amount of illumination on any surface depends upon the distance of the surface from the light source. A candle 1 foot away from a screen will shed more intense light on a given area of the screen than it would if it were 3 feet from the screen. In the latter case, it would illuminate a larger area with less intensity. The intensity of illumination is measured in foot candles. A foot candle is the amount of light intensity received on a surface 1 foot away from a light source of 1 candlepower.

c. The intensity of illumination or the quantity of light which is received per unit surface varies inversely as the square of its distance from the source.

$$\text{foot candles} = \frac{\text{Candlepower}}{(\text{distance})^2}$$

d. The amount of light falling upon a surface is measured in lumens. A lumen is the amount of light falling on an area of 1 square foot at 1 foot distance from a standard candle (a above). Therefore, total lumens divided by area equals foot candles of illumination.

**10-2. Diopters.**

a. General. The lens diopter or simply diopter is the unit of measure of the refractive power of a lens or lens system. The prism diopter is the unit of measure of the refracting power of a prism. Both are based on the metric system of measurement.

b. Lens Diopter. A lens with a focal length of 1 meter is internationally recognized to have the power of 1 diopter. The power of a converging lens is positive and that of a diverging lens is negative.

The power of other lenses than those of 1-meter focal length is the reciprocal of the focal length in meters and varies inversely as the focal length. This means that a converging lens with a focal length of 20 centimeters or 1/5 meter has a power of +5 diopters, while a diverging lens with a focal length of 50 centimeters or 1/2 meter has a power of -2 diopters. The lens with the shortest focal length has the greatest plus or minus power in diopters.

c. Prism Diopter. A prism with a power of 1 prism diopter will deviate light by 1 centimeter at a distance of 1 meter from the prism. Thus, the prism diopter designation of a refracting prism is the measurement of the amount it can bend light.

**10-3. Degree System.**

a. The degree system is a means of measuring and designating angles of arcs. The degree is 1/360 part of a circle or the value of the angle formed by dividing a right angle into 90 equal parts. Each degree is divided into 60 parts called seconds.

b. In the use of fire-control equipment, either degrees or mils (para 10-4) may be used to designate angles of elevation and azimuth. One degree equals 17.78 mils. One mil equals 0.0560 or 3 minutes 22 1/2 seconds. Refer to the conversion chart (fig 10-1) for the approximate relative values of given angles of elevation and azimuth in degrees and mils.

**10-4. Mil System.**

a. The artillery mil system is a means of angular measurement that lends itself to simple mental arithmetic. It provides accuracy within the limits demanded by the military forces with distinct advantages of simplicity and convenience not afforded by any other method of angular measurement. It is based on an arbitrary unit of measurement known as the mil. The mil is exactly 1/6400 of a complete circle.

b. The mil is very nearly the angle between two lines which will enclose a distance of 1 meter at a range of 1,000 meters (fig 10-1). Exact computation of the distance enclosed at 1,000 meters by 1 mil gives the result of 0.982 meters. Therefore in assuming that 1 mil encloses 1 meter at 1,000 meters, an error of 0.018 meter or 1.8 cm is introduced. This error is negligible for all practical purposes in the use of fire-control instruments.

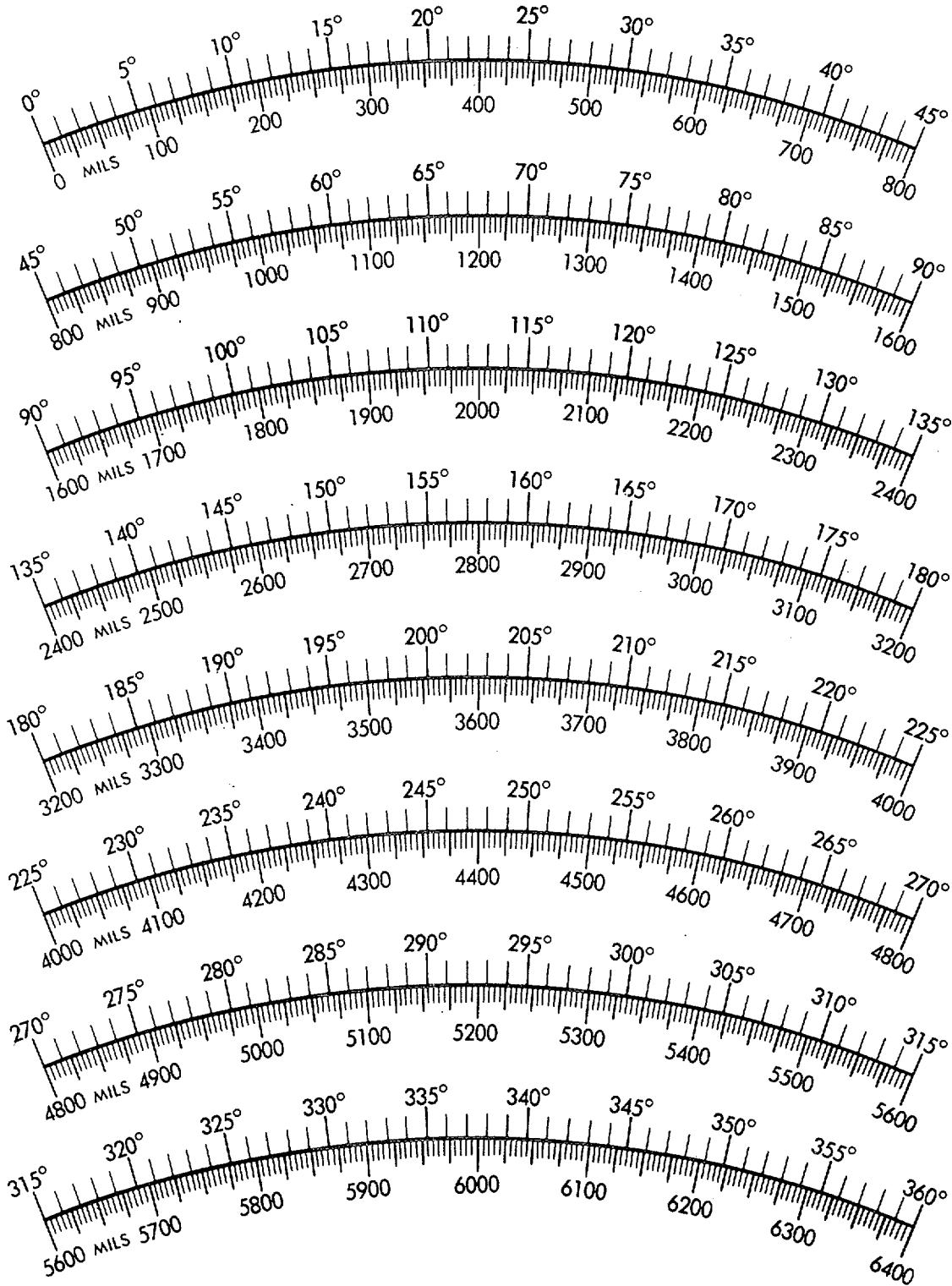

AR910199

Figure 10-1. Artillery mil-degree conversion chart.

c. A circle of 1,000 meters radius would have a circumference of 6,283 meters. A 1-meter portion of the circumference would be the 1/6283 fractional part of a circle. By choosing the mil as the 1/6400 fractional part of a circle, sufficient accuracy is retained for all practical purposes while the number can be handled easily by mental arithmetic.

d. The mil provides an extremely small unit of angular measurement that is easily adaptable to the small angles encountered by the artilleryman. For example, if an object has an angular width or height of 1 mil, it is 1 meter wide or high at 1,000 meters; 2 meters wide or high at 2,000 meters; and so on. In angular height, a man is approximately 2

mils tall at 1,000 meters or 1 mil tall at 2,000 meters.

**NOTE**

The Navy mil and the French infantry mil are exactly 1 meter at a range of 1,000 meters. There are 6283.1853 Navy or French infantry mils in a complete circle.

e. For quick approximate conversion from artillery mils to degrees, or vice versa, refer to figure 10-1. On this chart locate the number of degrees or mils to be converted. Directly across the black line of arc is its equivalent.

f. For more exact conversion from artillery mils to degrees, minutes, and seconds, use the following listing:

Artillery mils	Degrees	Minutes	Seconds
1.....	0	3	22.5
2.....	0	6	45
3.....	0	10	7.5
4.....	0	13	30
5.....	0	16	52.5
6.....	0	20	15
7.....	0	23	37.5
8.....	0	27	0
9.....	0	30	22.5
10.....	0	33	45
20.....	1	7	30
30.....	1	41	15
40.....	2	15	0
50.....	2	48	45
60.....	3	22	30
70.....	3	56	15
80.....	4	30	0
90.....	5	3	45
100.....	5	37	30
200.....	11	15	0
300.....	16	52	30
400.....	22	30	0
500.....	28	7	30
600.....	33	45	0
700.....	39	22	30
800.....	45	0	0
900.....	50	37	30
1,000.....	56	15	0
2,000.....	112	30	0
3,000.....	168	45	0
4,000.....	225	0	0
5,000.....	281	15	0
6,000.....	337	30	0
6,400.....	360	0	0

For example, to convert 2,569 mils:

2,000 mils =	1120	30'	0"
500 mils =	280	7'	30"
60 mils =	30	22'	30"
9 mile =	<u>0°</u>	<u>30'</u>	<u>22.5"</u>
	1430	89'	82.5"
2,569 mile =	1440	30'	22.5"

g. For more exact conversion from degrees and minutes to artillery mils, use this conversion table:

Degree	Minutes	Artillery mils
0	1.....	30
0	2.....	59
0	3.....	89
0	4.....	1.19
0	5.....	1.48
0	6.....	1.78
0	7.....	2.07
0	8.....	2.37
0	9.....	2.76
0	10.....	2.96
0	02.....	2.96
0	20.....	5.93
0	30.....	8.89
0	50.....	14.82
1	0.....	17.78
2	0.....	35.56
3	0.....	53.33
4	0.....	71.11
5	0.....	88.89
6	0.....	106.67
7	0.....	124.44
8	0.....	142.22
9	0.....	160.00
10	0.....	177.78
20	0.....	355.56
30	0.....	533.33
40	0.....	711.11
50	0.....	888.89
60	0.....	1,066.67
70	0.....	1,244.44
80	0.....	1,422.22
90	0.....	1,600.00
100	0.....	1,777.78
200	0.....	3,555.56
300	0.....	5,333.33
360	0.....	6,400.00

For example, to convert 78°43':

$$\begin{array}{r}
 70^\circ \ 0' = \quad 1,244.44 \\
 8^\circ \ 0' = \quad 142.22 \\
 0^\circ \ 40' = \quad 11.85 \\
 0^\circ \ 3' = \quad .89 \\
 \hline
 78^\circ \ 43' = 1,399.40 \text{ mils}
 \end{array}$$

**10-5. Metric System.**

a. The meter, which is the basis of the metric system, was intended to be and is very nearly one ten-millionth of the distance from the equator to the pole measured at sea level on the meridian of the earth. The meter is now defined as the distance between two lines on a certain platinum-iridium bar kept in Paris, when the bar is at 0° C. The value of the meter in wave length of light is known with very great accuracy. The value for the wave length of red cadmium radiation under specified standard conditions is 0.00064384696 mm. All

units of linear measurement of the metric system are multiples or fractional parts of the meter in the units of 10. It is a system based on decimals which provides ease of conversion from one to another of the various units of the system. Units of measurement are provided from extremely small to the very large, inasmuch as they include the physical units of measure of the X-ray Unit, micron, meter, and kilometer.

b. One meter is equal to 39.37 inches. Following is a listing of metric units with their equivalents in inches, yards, and miles:



	=	1 millimeter	=	0.03937 inch
10 millimeters=	=	1 centimeter	=	0.3937 inch
10 centimeters	=	1 decimeter	=	3.937 inches
10 decimeters	=	1 meter	=	1.0936 yards
10 meters	=	1 dekameter	=	10.936 yards
10 dekameters	=	1 hectometer	=	10.936 yards
10 hectometers	=	1 kilometer	=	0.6214 mile

c. One inch equals 25.4 millimeters. One foot equals 30.48 centimeters. One yard equals 0.914 meter. One mile equals 1.609 kilometers. For quick approximate conversion from inches to metric

system units, or vice versa, refer to the conversion table (fig 10-2). On this table, locate the measurement to be converted. Directly across the black line is its equivalent.

10 MILLIMETERS (MM) = 1 CENTIMETER  
 10 CENTIMETERS (CM) = 1 DECIMETER  
 10 DECIMETERS (DC) = 1 METER  
 10 METERS (M) = 1 DEKAMETER

10 DEKAMETERS (DAM) = 1 HECTOMETER  
 10 HECTOMETERS (HM) = 1 KILOMETER (KM)

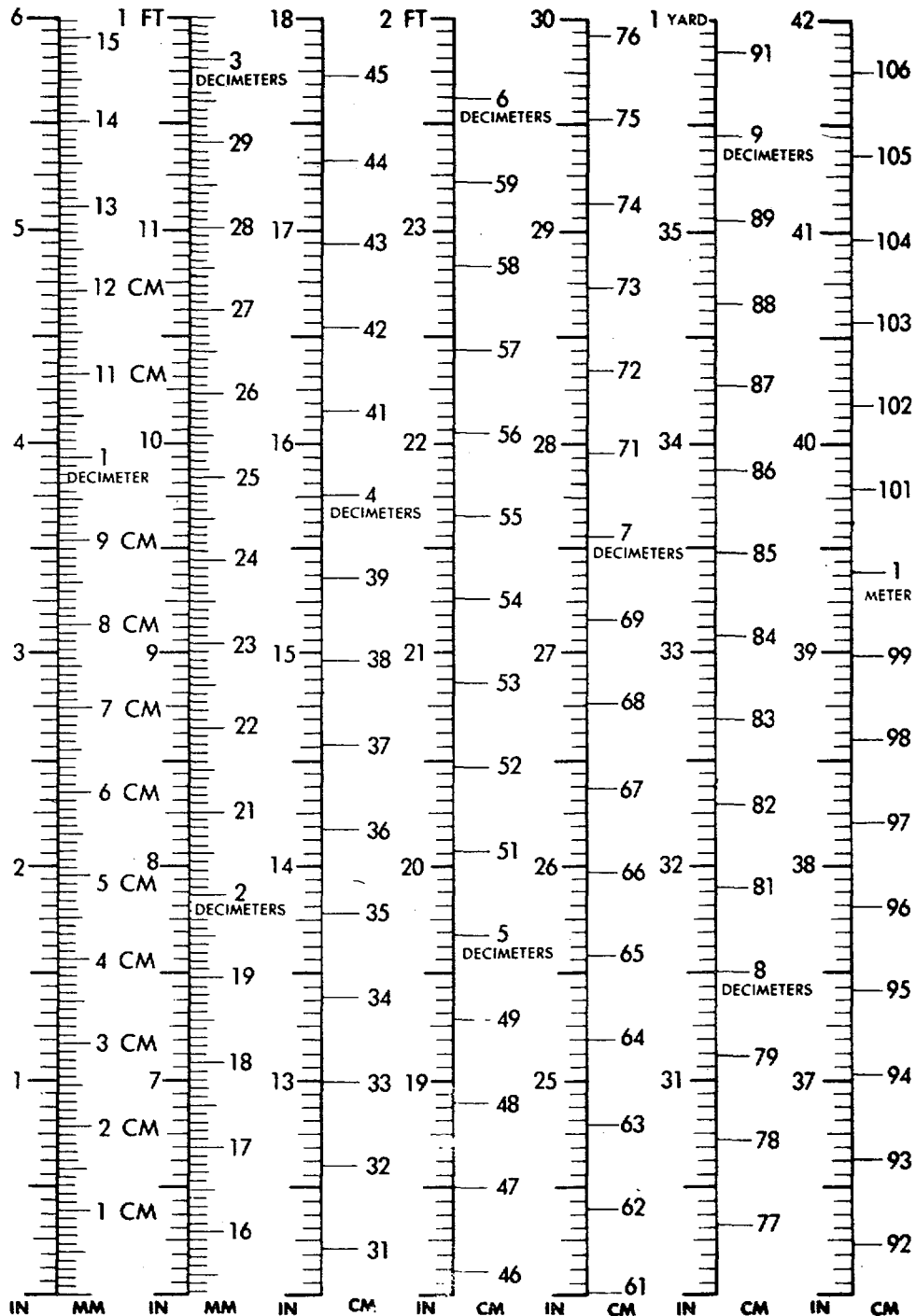

AR910200

Figure 10-2. Metric unit-inch conversion table.

d. For more exact conversion and for conversion of large units, use the following factors to convert:

From	To	Multiply
Millimeters .....	Inches.....	Millimeter by 0.03937
Inches.....	Millimeters .....	Inches by 25.4
Meters .....	Inches.....	Meters by 39.37
Meters .....	Yards.....	Meters by 1,0936
Inches.....	Meters .....	Inches by 0.0254
Yards.....	Meters .....	Yards by 0.9144
Kilometers .....	Miles.....	Kilometers by 0.6214
Miles.....	Kilometers .....	Miles by 1.609

APPENDIX A

REFERENCES

**A-1. Publication Indexes.** The following indexes should be consulted frequently for latest changes or revisions of references given in this appendix and for new publications relating to materiel covered in this manual:

Index of Army Motion Pictures, Film Strips, Slides, and Phono-Recordings. DA Pam 108-1

Military Publications:

- Index of Administrative Publications ..... DA Pam 310-1
- Index of Blank Forms ..... DA Pam 310-2
- Index of Graphic Training Aids and Devices ..... DA Pam 310-5
- Index of Supply Manuals; Ordnance Corps ..... DA Pam 310-6
- Index of Technical Manuals, Technical Bulletins (Type 7, 8, ..... DA Pam 310-4  
and 9), Lubrication Orders, and Modification Work Orders.
- Index of Doctrinal, Training, and Organizational Publications ..... DA Pam 310-3

**A-2. Other Publications.**

- Elements of Optics and Optical Instruments ..... ST 9-2601-1
- Military Symbols ..... FM 21-30
- Military Terms, Abbreviations, and Symbols: Authorized Abbreviations ..... AR 320-50  
and Brevity Codes.
- Dictionary of United States Army Terms ..... AR 320-5
- Military Training FM 21-5
- Techniques of Military Instruction ..... FM 21-6

**A-3. Textbooks.**

A College Textbook of Physics by Arthur L. Kimbal-Henry Holt and Co., New York - 1939. The Principles of Optics by Arthur C. Hardy and Fred H. Perrin - McGraw-Hill Book Co., Inc., New York and London - 1932.

## APPENDIX B

### GLOSSARY

**B-1. General.** This glossary contains definitions of a number of specialized terms found in the study of optics, in the use of sighting and fire-control equipment, and with reference to the eyes and vision. It includes definitions of most of the more unusual words used in this manual. The majority of the *italicized* words in this manual will be found in this glossary. When in doubt as to the meaning of a word, refer to this glossary.

**B-2. Glossary.**

*Abbe prism* - Two right-angle prisms joined to form one prism (fig 4-16). Used as component of one form of the Abbe prism system (figs 4-10 and 4-21).

*Abbe prism erecting system* - A prism erecting system in which there are four reflections to erect the image. It is composed of two double right-angle prisms which bend the path of light 360°, displacing but not deviating the path of light (fig 4-21).

*Aberration* - Any defect of a lens or optical

system which causes the image to be imperfect. See astigmatism, chromatic aberration, coma, curvature of image, distortion, and spherical aberration.

*Absorption* - The act or process by which an object or substance "takes up" or "soaks up" all the colors contained in a beam of white light except those colors which it reflects or transmits. Because of absorption, objects appear to have different colors; white objects have little absorption; other objects having varying powers of absorption appear to have different colors and different shades of brightness. For example, an object which appears red has absorbed all the color of the spectrum except the color red. This is known as selective absorption or selective reflection. A piece of ruby glass placed between the eye and a source of white light allows only red light to pass through because it absorbs all other colors. This is called selective absorption or selective transmission (fig B-1).

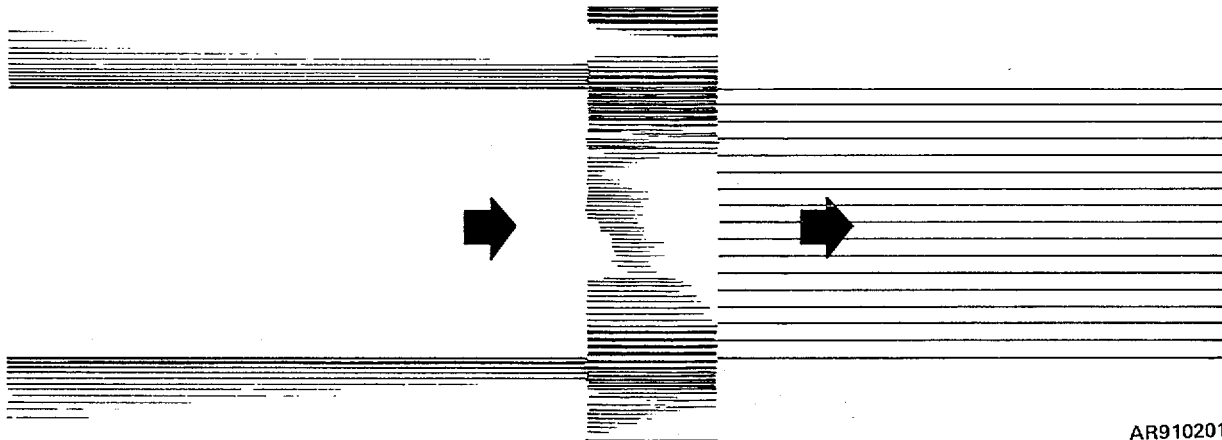

AR910201

Figure B-1. Absorption-Selective transmission.

*Accommodation* - Automatic adjustment of the crystalline lens of the human eye for seeing objects at different distances. The process whereby the crystalline lens is adjusted to focus successive images of objects located at various distances from the eye. See limits of accommodation.

*Achromatic* - Without color.

*Achromatic lens* - A lens consisting of two or more elements, usually made of crown and flint

glass, which has been corrected for chromatic aberration. See compound lens.

*Acuity* - Keeness; sharpness. See stereo-acuity and visual acuity.

*Adapter* - A tube, ring, or specially formed part which serves to fit or connect one part with another, or mount an element of smaller diameter into a part of larger diameter.

*Aiming circle* - An instrument for measuring

horizontal and vertical angles and for general topographic work.

*Aiming point* - The point on which the gunner sights when aiming the gun. This point is not necessarily the target itself.

*Ametropia* - Any abnormal condition of the seeing power of the eyes, such as *farsightedness* (hypermetropia), *nearsightedness* (myopia), or *astigmatism*. An ametropic eye is one which does not form distinct images of objects on its retina.

*Amici prism* - Also called "roof prism" and "roof-angle prism." A form of roof prism designed by G. B. Amici, consisting of a roof edge formed upon the long reflecting face of a right-angle prism

(fig 4-11). Used as an erecting system in elbow and panoramic telescopes. It erects the image and bends the line of sight through a 90° angle.

*Anastigmat* - A compound lens corrected for astigmatism. Angle The amount of rotation of a line around the point of its intersection with another, necessary to bring it into coincidence with the second line.

*Angle of azimuth* - An angle measured clockwise in a horizontal plane usually from north (fig B-2). The north used may be True North, Magnetic North, or Y-North (Grid North).

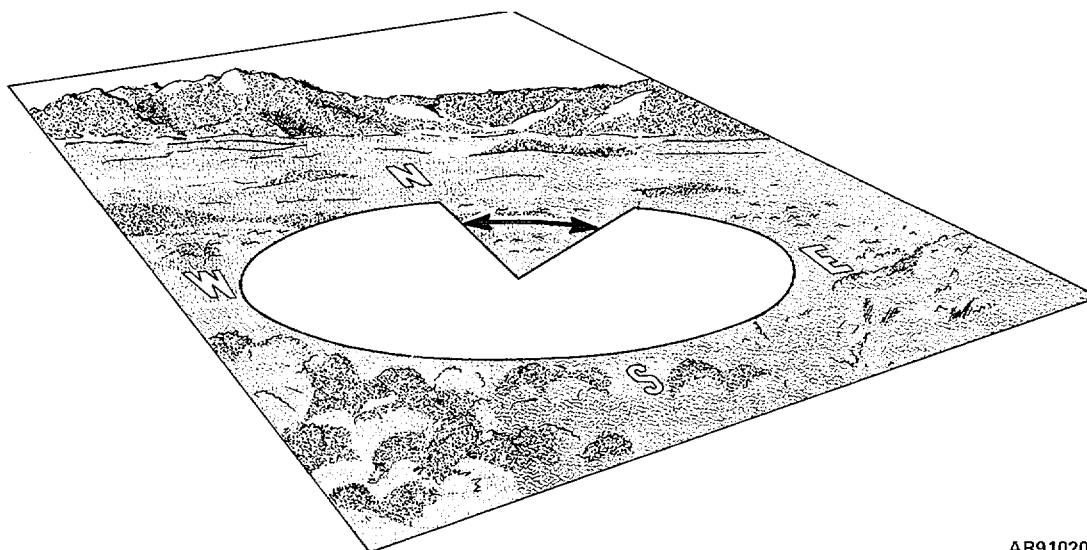

AR910202

Figure B-2. Angle of azimuth.

*Angle of convergence* - Angle formed by the lines of sight of both eyes in focusing on any point, line, corner, surface, or part of an object Also referred to as *convergence angle* (figs 3-8 and 3-9).

*Angle of deviation* - The angle through which a ray of light is bent by a refracting surface; the angle between the extension of the path of an

incident ray and the refracted ray (fig 2-24).

*Angle of elevation* - The angle between the *line of site* (line from gun to target) and *line of elevation* (axis of bore when gun is in firing position) (fig B-3). The *quadrant angle of elevation* is the angle between the horizontal and the line of elevation. *Angle of elevation* plus angle of site equals *quadrant angle of elevation*.

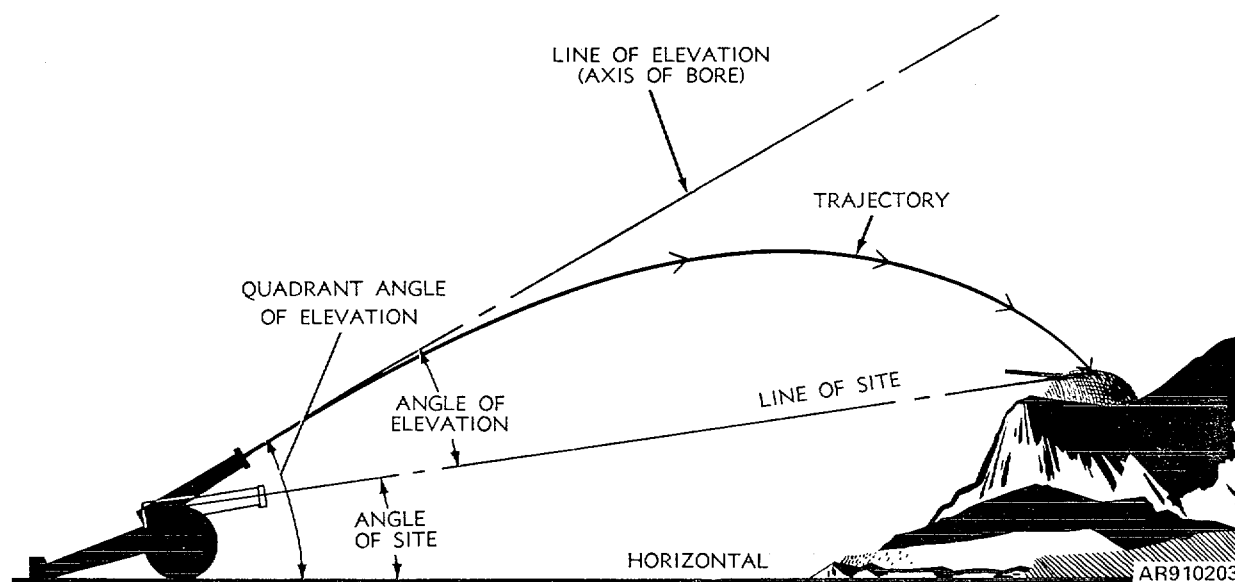

Figure B-3. Angle of elevation, angle of site, and quadrant angle.

*Angle of incidence* - The angle between the normal (perpendicular) to a reflecting or refracting surface and the incident ray (figs 2-13 and 2-24).

*Angle of reflection* - The angle between the normal to a reflecting surface and the reflected ray (fig 2-13). The incident ray, reflected ray, and normal all lie in the same plane.

*Angle of refraction* - The angle between the normal to the refracting surface and the refracted ray (fig 2-24). The incident ray, refracted ray, and normal all lie in the same plane.

*Angle of site* - The vertical angle between the horizontal and the line of site (line from gun to

target) (fig B-3).

*Angstrom unit* - A unit of measure equaling one ten-millionth part of a millimeter.

*Angular* - Composed of or measured by angles.

*Antiglare diaphragm* - See diaphragm.

*Aperture* - An opening or hole through which light or matter may pass. In an optical system, it is equal to the diameter of the largest entering beam of light which can travel completely through the system. This may or may not be equal to the aperture of the objective (fig B-4).

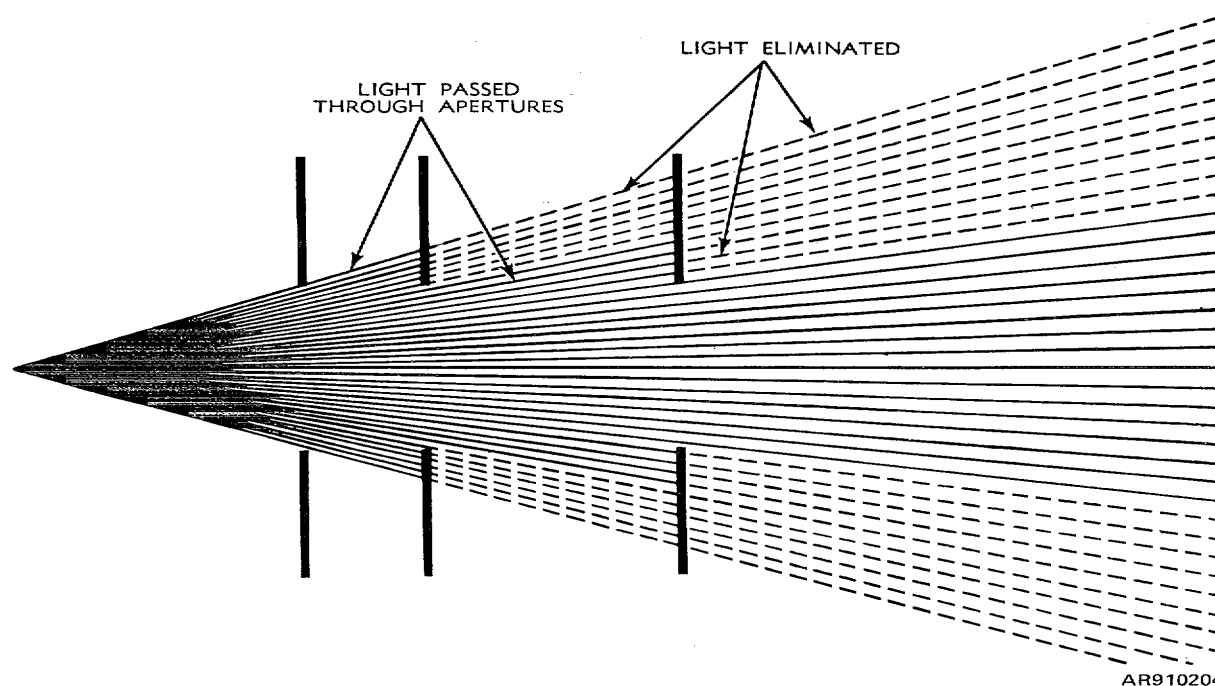

Figure B-4. Apertures.

*Aperture of objective* - The diameter of that part of the objective which is not covered by the mounting.

*Aperture stop* - The diaphragm which limits the size of the aperture. See diaphragm.

*Aplanatic lens* - A lens which has been corrected for spherical aberration, coma, and chromatic aberration.

*Achromatic lens* - A lens, usually consisting of three components of different kinds of glass (two crown glass elements, one flint glass element), which has been corrected for chromatic aberration with respect to three selected colors or wavelengths of light.

*Apparent field of view* - The angular size of the field of view of an optical instrument, as seen through the instrument by the eye (fig 2-51). See field of view.

*Aqueous humor* - The transparent liquid which

is contained between the cornea and the crystalline lens of the eye (fig 3-2).

*Arc* - A part of the circumference of a circle.

*Artillery* - mil See mil.

*Asthenopia* - Weakness or rapid fatigue resulting from use of the eyes indicated by headache or pain in the eyes. Often referred to as weak sight or eyestrain.

*Astigmatism*

a. An aberration or defect of a lens which causes a point of the object off the axis to be imaged as a short line or pair of short lines. When two lines are formed, each is at a different distance from the lens and is at an angle to the other, and the lens has two points of principal focus (B, fig B-5). A sharp image cannot be secured at either focal point and the best results are obtained at a point between the two focal points in a plane known as the *circle of least confusion* (fig 2-64).



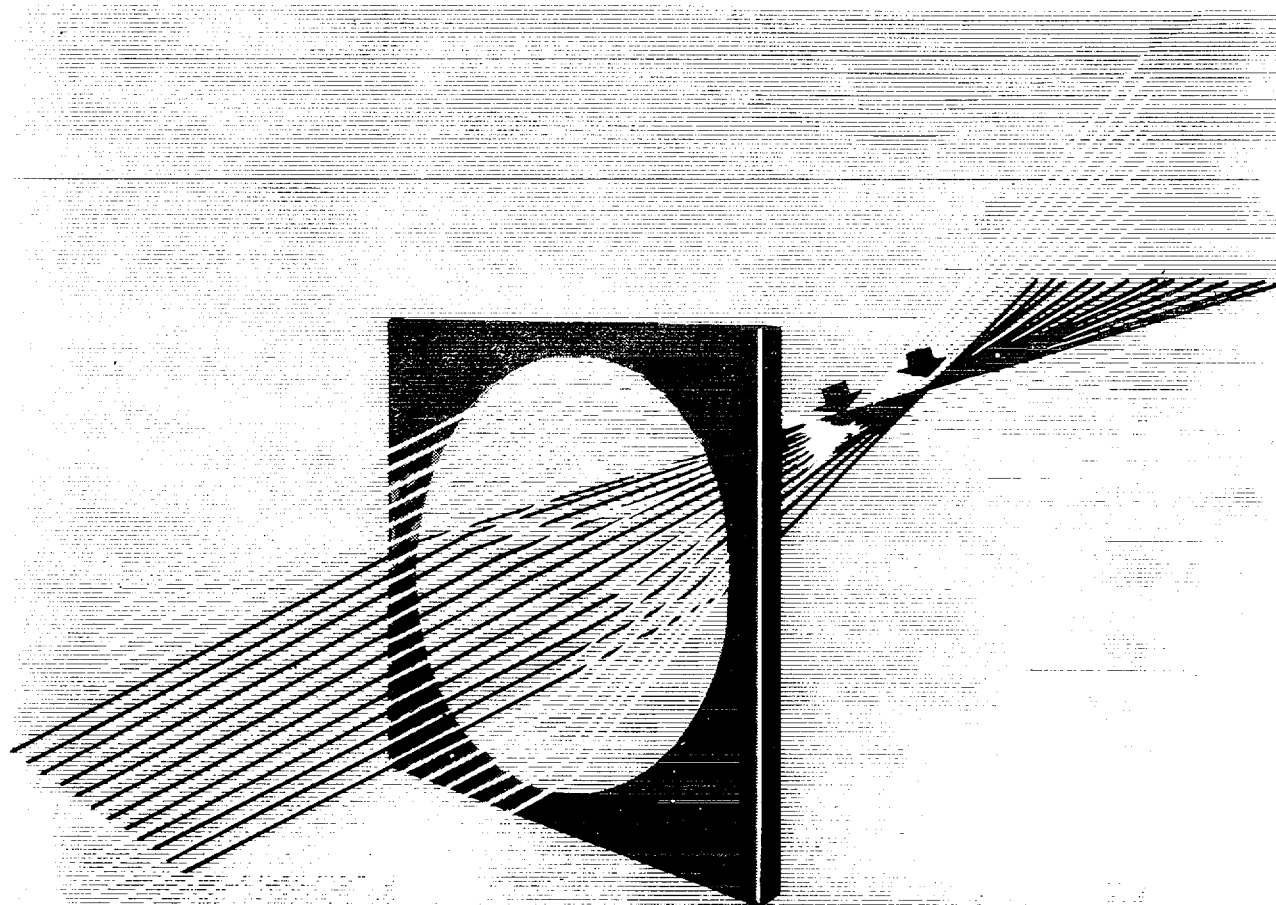
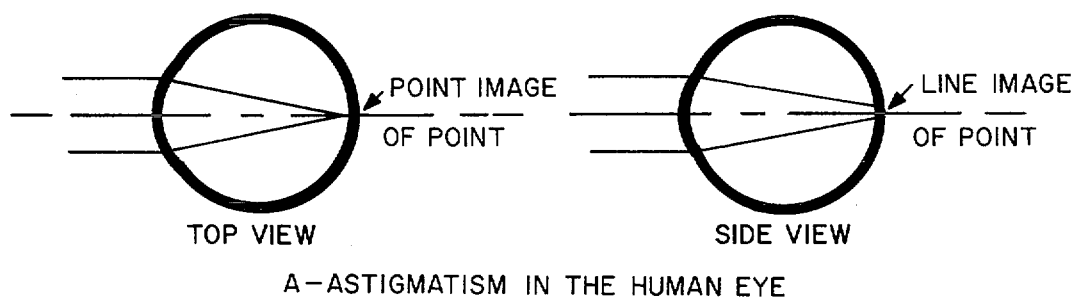

B-ASTIGMATISM OF A LENS

AR910205

Figure B-5. Astigmatism

*b.* A defect of the human eye causing straight lines in a certain direction to appear blurred and distorted while lines in another direction may be well defined. This defect results when rays from a point are not brought to a single focal point on the image on the retina but a short line is formed. It is caused by unsymmetrical surfaces of the cornea and the crystalline lens of the eye (A, fig B-5).

*Astigmatizer* - A cylindrical lens which may be rotated into the line of sight of a range finder to cause the effect of astigmatism, to stretch a ray of light from a single point to form a line.

*Axis (plural, axes)* - A straight line passing through a body and indicating its center. See axis of bore, principal axis, and optical axis.

*Axis of bore* - The center line or straight line

through the center of the bore of a gun (fig B-6). The line of sight of the sighting instrument of a

gun is adjusted parallel to the axis of bore.

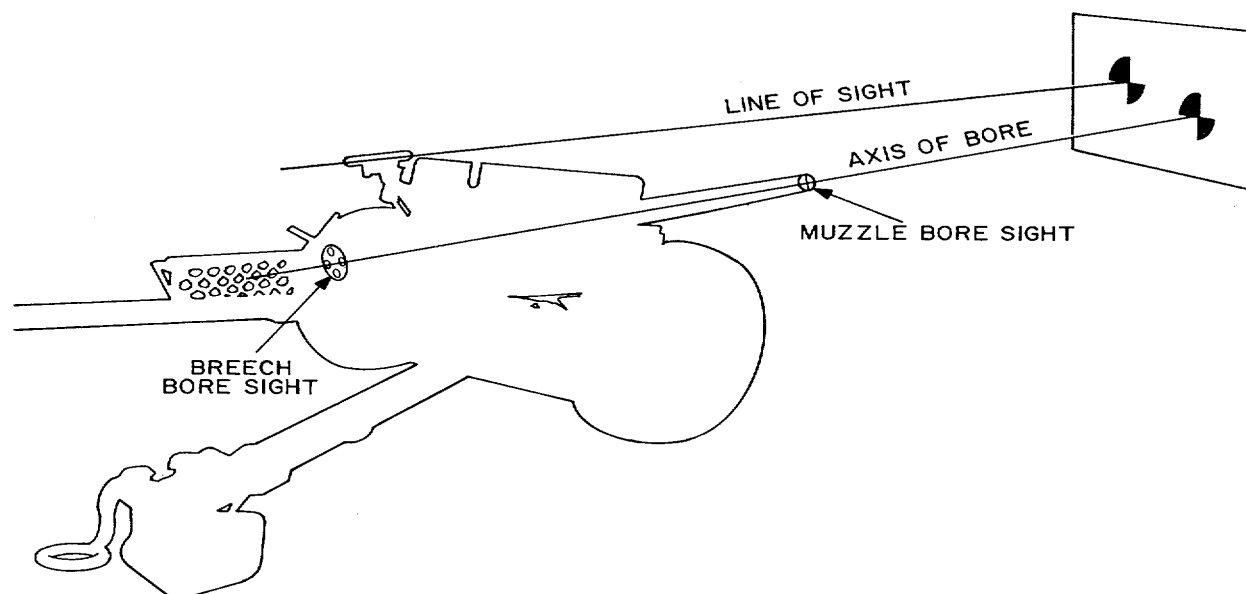

AR910206

Figure B-6. Axis of bore and boresights-boresighting.

*Axis of lens* - See principal axis.

*Azimuth* - An angle measured clockwise in a horizontal plane from a known reference point frequently one of the norths: True North, Magnetic North, or Y-North (Grid North). (See angle of azimuth). Also used as an adjective to indicate reference to movement in an horizontal plane as *azimuth mechanism* or *azimuth instrument*. To traverse the carriage of a weapon in azimuth means to rotate the weapon from side to side in a horizontal plane.

*Azimuth instrument* - A telescopic instrument used for measuring horizontal angles.

*Azimuth mechanism* - Any mechanical means provided for turning an instrument in azimuth (in horizontal plane). It may contain a worm and wormwheel to give accurate, smooth movement.

*Backlash* - A condition wherein a gear, forming part of a gear train, may be moved without moving the next succeeding or preceding gear. It

is due to space between the teeth of the meshing gears.

*Balance* - See orthophoria.

*Balsam* - See Canada balsam.

*Base length* - In range finders, the actual optical length of the instrument. It is approximately equal to the distance between the centers of the end windows. It is the base of the range triangle by means of which the range is computed (fig 8-23).

*BC periscope (Battery Commander's Periscope)* - A binocular telescope used for observing artillery fire.

*Beam* - With reference to light, a shaft or column of light; a bundle or rays. It may consist of parallel, converging, or diverging rays.

*Binocular* - Pertaining to vision with both eyes. Also, a term applied to instruments consisting of two telescopes utilizing both eyes of the observer.

*Blind spot* - The part of retina, inner coat of eyeball, not sensitive to light where the optic nerve enters.

*Bore sight* - A sighting device consisting of a breech element and a muzzle element which, inserted in a gun, is used to determine the axis of the bore and the alinement of other sighting equipment with the axis of the bore. A bore sight may consist of a metal disk with a peephole for the breech and a pair of crosslines for the muzzle (fig B-6).

*Boresight* - To adjust the line of sight of the sighting instrument of a gun to the axis of the bore (fig B-6).

*Brightness of image* - A term used to denote the amount of light transmitted by an optical system to give definition to the image seen by the observer.

*Burnishing* - The process of turning a thin edge of metal over the edge of a lens to hold it in place in its cell (fig B-7). This eliminates the use of a retaining ring. Burnished optics are usually procured as assemblies, inasmuch as it is difficult to replace their component parts.

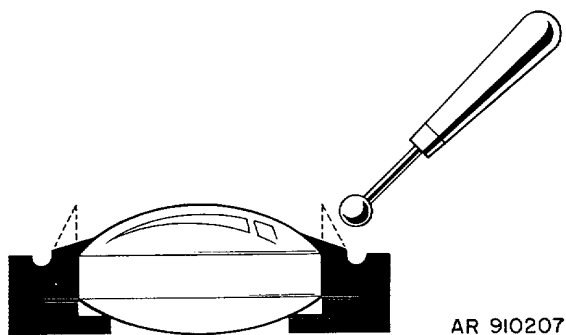

Figure B-7. Burnishing

*Case I pointing (or firing)* - Direct pointing, laying, or fire; gun pointing in which direction and elevation are set with sight of telescope pointed at the target.

*Case II pointing (or firing)* - Combined direct and indirect pointing, laying, or fire; gun pointing in which direction is set with a sight or telescope pointed at the target and the elevation with an elevation quadrant, range quadrant, or range disk.

*Case III pointing (or firing)* - Indirect pointing, laying, or fire; gun pointing in which direction is set with an azimuth circle or with a sight or telescope pointed at an aiming point other than the target; the elevation is set with an elevation quadrant, range quadrant, or range disk.

*Cataract* - A diseased condition of the human eye in which the cornea or crystalline lens becomes opaque resulting in blindness.

*Cell* - A tubular mounting used to hold a lens in its proper position. The lens may be held in the cell by burnishing or by a retaining ring.

*Center of curvature* - The center of the sphere of which the surface of a lens or mirror forms a part. Each curved surface of a lens has a center of curvature (fig B-8). The curved surfaces may be convex or concave.

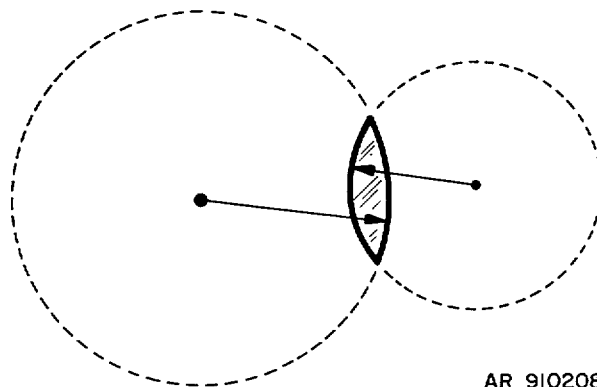

Figure B-8. Centers of curvature

*Calcite* - See Iceland spar.

*Canada balsam* - A clear, practically colorless sap of fir, solidifying to a transparent resin used in cementing optical elements together particularly the components of a compound lens. It is used because it has approximately the same index of refraction as glass.

*Candlepower* - A unit of measure of the brightness or power of any light source. One candlepower is the rate at which a standard candle, initially made of sperm whale oil, 7/8 inch in diameter, burning at the rate of 120 grains per hour, emits light. Current standards of candlepower are electric lamps.

*Centric Pencil* - Oblique pencil or cone of light which passes through the center of a lens at a considerable angle to the principal axis.

*Choroid* - The opaque middle coat or tunic of the human eye. It is a deep purple layer made up of blood vessels; it supplies nourishment to the eye tissues and shuts out external light (fig 3-2).

*Chromatic aberration* - An aberration (deviation from normal) of a lens which causes

different colors of wavelengths of light to be focused at different distances from the lens resulting in colored fringes around the borders of objects seen through the lens (fig 2-60).

*Ciliary body or muscle* - The muscle in the eyeball which is capable of increasing or decreasing the curvature of the crystalline lens to decrease or increase the focal length of the lens system of the eye. Used in accommodation (focusing) of the eye (fig 3-4).

*Circle of least confusion* - A focal plane between the two focal points of a lens affected by astigmatism where the most clearly defined image can be obtained. See astigmatism.

*Coated optics* - Optical elements which have been coated with a thin chemical film, such as magnesium fluoride, to reduce reflection and thereby increase light transmission.

*Coincidence* - Occupying the same place; agreeing as to position; corresponding. In the coincidence range finder, two optical systems are focused into a single eyepiece assembly. When the range knob is rotated, the left and right fields of view are superimposed and coincidence of the two images of the selected target is established.

*Coincidence prism* - A compound prism, consisting of a system of small prisms cemented together, used as an ocular prism assembly in a coincidence range finder to bring the image from the two objectives to a single eyepiece for viewing.

*Coincidence range finder* - A self-contained distance measuring device operating on the principle of triangulation. Images, observed from points of known distance, are aligned to determine the range. See coincidence.

*Collective lens* - A convex or positive lens used in an optical system to collect the field rays and bend them to the next optical element. It prevents loss of rim ray light. Sometimes used to denote a convergent or convex lens.

*Collimating telescope* - A telescope with an outer cylindrical surface that is concentric with its optical axis. It contains a reticle, usually straight crosslines. It is used to align the axis of the optical elements to the mechanical axis of the instrument (collimation) in other telescopes, to focus eyepieces, and to set diopter scales at infinity focus.

*Collimation* - The process of aligning the axis of the optical elements to the mechanical axis of an instrument.

*Collimator* - A sighting instrument occupying a position between the open sight and the telescopic instrument (fig 8-27). It has an eyelens, and reticle of cross or vertical line pattern.

*Color blindness* - An eye condition of not being capable of proper discrimination of colors. In the most common type, *dichromatism*, red-green blindness, these two colors appear gray.

*Coma* - An aberration of a lens which causes oblique pencils of light from a point on the object to be imaged as a comet-shaped blur instead of a point. This aberration is caused by unequal refraction through the different parts of the lens for rays coming from a point which lies a distance off the axis (fig 2-65).

*Compass North (Magnetic North)* - The direction indicated by the north-seeking end of the needle of a magnetic compass. This direction is different usually from either True North or Y-North (Grid North), depending upon one's position upon the earth's surface.

*Compensator* - See measuring wedge.

*Compound lens* - A lens composed of two or more separate pieces of glass. These component pieces or elements may or may not be cemented together. A common form of compound lens is a two element objective; one element being a converging lens of crown glass and the other being a diverging lens of flint glass. The surfaces of the two elements are ground to eliminate aberrations which would be present in a single lens (fig 4-3).

*Concave* - Hollowed to form a shallow cavity and rounded like the inside of a sphere.

*Concave lens* - See diverging lens.

*Concave-convex lens* - A lens with one concave surface and one convex surface.

*Concentric* - Having the same center. Circles differing in radius but inscribed from a single center point.

*Cone* - One of the two types of light-sensitive elements or visual cells in the retina of the eye which permit sight. The cones are associated with daylight vision and give clear sharp vision for the seeing of small details and the distinguishing of color. The other type of visual cell is termed the rod (fig 3-5).

*Conjugate focal points (conjugate foci)* - Those pairs of points on the principal axis of a concave mirror or a convergent lens so located that light emitted from either point will be focused at the other as shown in figure B-9 where D and D- are the conjugate focal lengths of a lens. Shifting the source of light along the axis will cause a shifting of the second corresponding conjugate focal point. Likewise related points in object and image are located optically so that for every point on the object there is a corresponding point in the image.

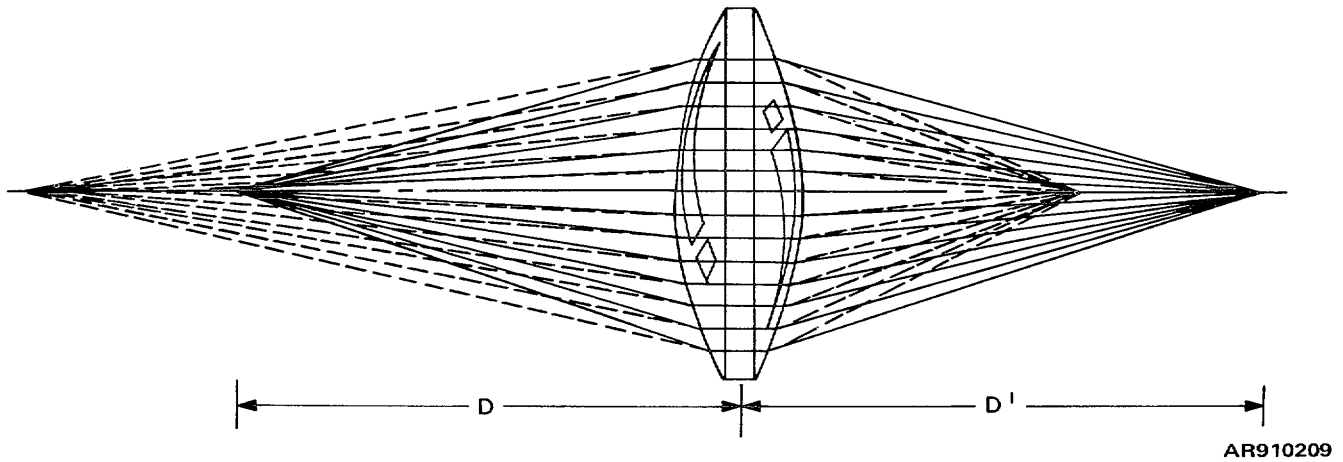

Figure B-9. Conjugate focal points (conjugate foci).

*Constant deviation* - A certain amount of deviation given to the line of sight or optical axis of one of the internal telescopic systems of a range finder in order that the correction wedge may adjust the system by supplying a plus, neutral, or minus correction, as required.

*Converge* - As applied to the eyes or binocular optical instruments, to direct them so that the two lines of sight meet at a common focus and form an angle. To direct light rays or lines to a small area.

*Convergence* - See angle of convergence.

*Convergent lens* - See converging lens.

*Converging lens* - Also known as convergent lens, positive lens, convex lens, collective lens. A lens that will converge light. One surface of a converging lens may be convexly spherical and the other plane (planoconvex), both may be convex (double convex) or one surface may be convex and the other concave (convexo-concave meniscus converging). A converging lens is always thicker at the center than at the edge (fig B-10).

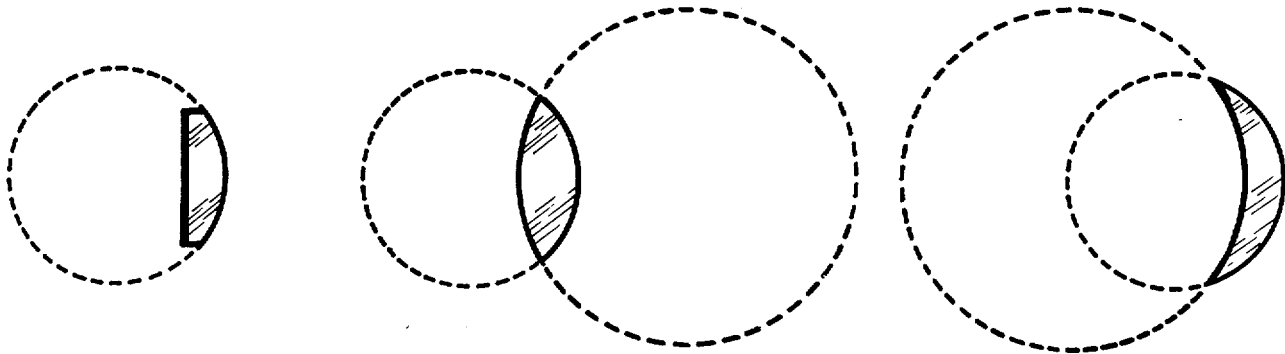

AR910210

Figure B-10. Converging lenses.

*Converging meniscus lens* - See meniscus converging lens.

*Convex* - Rounded and bulging outwardly as the outer surface of a sphere.

*Convex lens* - See converging lens.

*Convexo-concave lens* - A lens with one convex and one concave surface.

*Cornea* - The transparent, slightly bulging front surface of the eyeball through which all light enters (fig 3-2). It serves as one of the lenses of the eye.

*Corrected lens* - A compound lens, the various surfaces of which have been so designed with respect to each other that the lens is reasonably free from one or more aberrations.

*Correction wedge* - In range finders a rotating wedge-shaped element used to precisely divert the line of sight to correct errors in the optical system caused by temperature variations. In range finders, serves to supply a measuring factor correction for the constant deviation given one of the telescopes. The measuring factor correction is read on a scale.

*Correction window* - End correction window. These are optical wedges of very small angles. They admit light, seal out dirt and moisture, and are so mounted that they may be rotated to compensate for the accumulated errors in the entire system. Two are used as end windows on some range finders.

*Critical angle* - That angle at which light, about to pass from a medium of greater optical density, is refracted along the surface of the denser medium (fig 2-34). When this angle is exceeded, the light is reflected back into the denser medium. The critical angle varies with the index of *refraction* of the substance or medium.

*Cross-eye* - See strabismus.

*Crown glass* - One of the two principal types of optical glass; the other type is flint glass. Crown glass is harder than flint glass, has a lower index of refraction, and lower dispersion. See compound lens.

*Crystalline lens* - The flexible inner lens of the eye which provides accommodation for sharply focusing near and distant objects (fig 3-2).

*Curvature of field* - See curvature of image.

*Curvature of image* - An aberration of a lens which causes an image to be focused in a curved plane instead of a flat one (A, fig 2-68).

*Cylindrical lens* - A lens having for one of its surfaces a segment of a cylinder. Lenses ground in this manner are used in spectacles to correct astigmatism of the eyes and in some of the coincidence range finders to cause astigmatism by stretching points of light into lines of light.

*Dark-adapted* - A term applied to the adjustment of the visual cells of the retina of the eye for better vision under conditions of poor lighting. It

applies to the process whereby the rods of the retina take over the major portion of the act of seeing.

*Definition* - Sharpness of focus: distinctness of image.

*Deflection* - A turning aside from a straight course. The horizontal clockwise angle from the line of fire to the line of sight to the aiming point. A small horizontal (traverse) angle by which a gun is aimed slightly away from its target to allow for factors such as wind and drift. See drift.

*Degree* - A unit of measurement equal to the angle between radii subtended by 1/360 of a circle.

*Depth perception* - The ability to see in depth or three dimensions. In addition to *stereoscopic vision*, light and shade, perspective, convergence of the visual axes of the two eyes, one object or part concealing another, atmospheric haze, and apparent size are factors which aid depth perception.

*Deviation* - Turning aside from a course; deflection; difference. In optics, the bending of light from its path. In gunfire, the distance from a point or center of impact to the center of a target.

*Dialyte* - A type of compound lens in which the inner surfaces of the two elements are ground to different curvatures to correct for aberrations and the dissimilar faces cannot be cemented together (fig 4-3). *Gauss objective* (para 4-3b).

*Diaphragm* - A flanged or plain ring with a limited aperture placed in an optical system at any of several points to cut off marginal rays of light not essential to the field of view. Diaphragms are used as: *field stops*, to reduce aberrations; *aperture stops*, to limit the aperture or light-gathering power of the instrument; and *antiglare diaphragms*, to eliminate reflections from the sides of the tube and consequent glare in the field of view. Lens cells or the sides of the tube may act as diaphragms. The rays eliminated by diaphragms are those which would cause aberrations or glare and ghost images by reflection inside the instrument.

*Dichromatism* - See color blindness.

*Diffusion* - The scattering of light by reflection or transmission. Diffuse reflection and transmission result when light strikes an irregular surface such as a frosted window or the surface of a frosted light bulb. When light is diffused, no definite image is formed.

*Diopter* - A unit of optical measurement which expresses the refractive power of a lens or prism. In a lens or lens system, it is equivalent to the reciprocal of the focal length in meters. For example, if a lens has a focal length of 25 centimeters, this figure converted into meters would equal 1/4 meter. In as much as the reciprocal of 1/4 equals 1 divided by 1 which equals 4, such a lens would be said to have

a power of 4 diopters. The lens with the shorter focal length has the greater power in diopters. See prism diopter.

*Diopter movement* - A term applied to adjustment of the eyepiece of an instrument to provide accommodation for eyesight variations of individual observers.

*Diopter scale* - A scale usually found on the focusing nut of the eyepiece of an optical instrument. It measures the change in refracting power of the eyepiece in diopters to introduce a correction to compensate for the-nearsightedness or farsightedness of the individual observer. It permits presetting of the instrument if the observer knows his diopter correction.: *Dioptometer* - Precision instrument used in determining the diopter setting of another instrument.

*Dioplopia* - See double vision.

*Discernible difference of convergence angles* - The differences in the angles of view from the two eyes to objects or parts of objects. These differences, although small, permit persons with normal, two-eyed vision to distinguish which of two objects is farther away, making stereoscopic vision possible without resorting to the other factors which aid *depth perception*.

*Dispersion* - In optics, the separation of a beam of white light into its component colors as in passing through a prism (fig 2-51). See spectrum.

*Dispersive lens* - See diverging lens.

*Distortion* - The aberration of a lens or lens system which causes objects to appear misshapen or deformed when seen through the lens or lens system. This defect is known as "barrel-shaped" distortion when the center of the field of view is enlarged with respect to the edges and "hourglass" or "pincushion" distortion when the edges are enlarged with respect to the center (fig 2-67). Wavy lines are sometimes produced by improperly shaped or polished windows, prisms, and mirrors. When caused by a lens, it is due to varying magnification of different parts of the image.

*Diverge* - In a lens, to deviate the light outward from a common center in different directions. As applied to the eyes, the action of the pupils being directed outward (Walleye vision) or in not being brought to a common focus.

*Divergent lens* - See diverging lens.

*Diverging lens* - Also known as divergent lens, negative lens, concave lens, dispersive lens. A lens which causes parallel light rays to spread out. One surface of a diverging lens may be concavely spherical and the other plane (planoconcave), both may be concave (double concave) or one surface may be concave and the other convex (concavo-convex meniscus diverging). The diverging lens is always thicker at the edge than at the center (fig B-11).

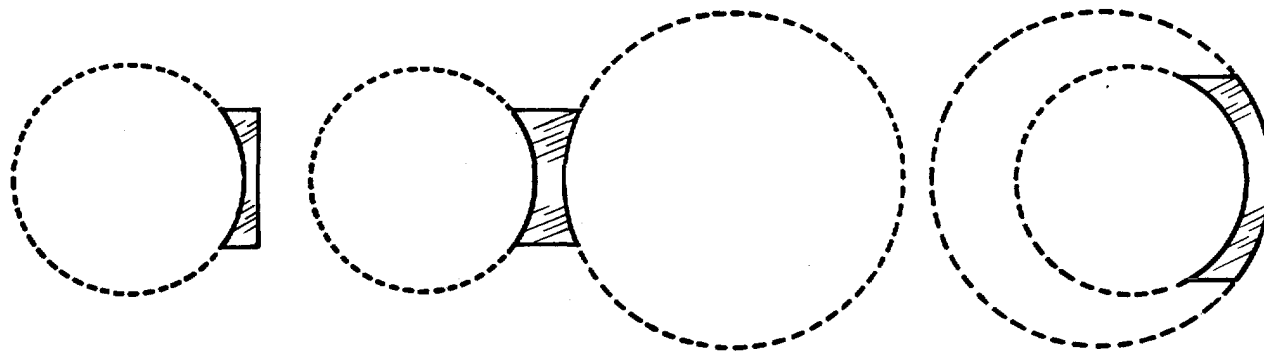

AR910211

Figure B-11. Diverging lenses.

*Diverging meniscus lens* - See meniscus diverging lens.

*Double concave lens* - A lens with two concave surfaces (fig 4-1).

*Double convex lens* - A lens with two convex surfaces (fig 4-1).

*Double right-angle Abbe prism* - See Abbe prism.

*Double vision* -

a. A malfunction of a binocular instrument causing two images to be seen separately instead of being fused. It is caused by the optical axes of the

two telescopes not being parallel or not converging to a point. In minor cases, the eyes will adjust themselves to compensate for the error of the instrument until the images are superimposed and only one object is seen. This may cause eyestrain, eye fatigue, and headaches.

b. An eye disorder, known as diplopia, which results in double vision of a single object. It is usually caused by one eye failing to converge or diverge in unison with the other eye.

*Doublet* - A compound lens consisting of two elements with inner surfaces curved identically and

cemented together (fig 4-3).

*Dove prism* - Used as a rotating prism. A form of prism designed by H. W. Dove. It is used to invert the image in one plane without deviating or displacing the axis of the rays of light. Used as the rotating prism in the conventional type of optical system of panoramic telescopes (figs 4-13 and 4-22).

*Drift* - The amount by which a projectile will deviate horizontally from its proper path, due to rotation caused by the rifling in the bore of the gun, and reaction of the air (fig B-12).

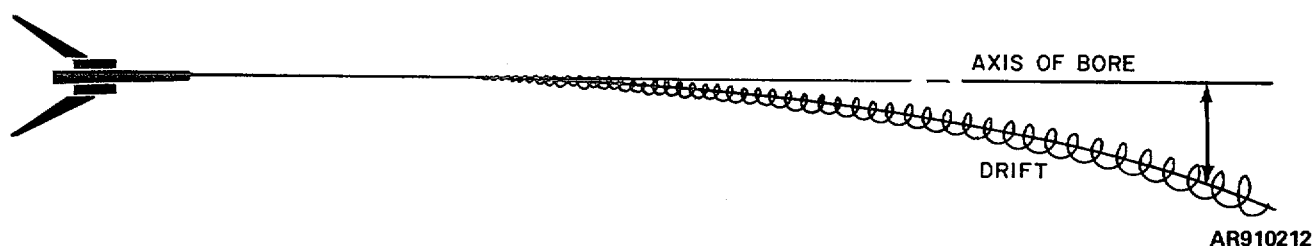

Figure B-12. Drift.

*Dynamometer* - A Ramsden dynamometer is a small eyepiece or magnifier equipped with a reticle scale and used in the precise measurement of the exit pupil and eye distance (eye relief) of other optical instruments.

*Eccentric mounting* - A type of lens mounting consisting of eccentric rings which may be rotated to shift the axis of the lens to a prescribed position (fig 4-36).

*Eccentric ray* - One of the rim rays which pass through a lens remote from its center.

*Effective aperture of objective* - See aperture of objective.

*Elbow telescope* - A refracting optical instrument for viewing objects in which the line of sight is bent 90 degrees by means of a prism.

*Electromagnetic spectrum* - A chart or graph showing the relation of all known electromagnetic wave forms classified by wavelength. The visible light spectrum occupies an extremely minute portion of the electromagnetic spectrum (fig 2-3).

*Elementary lens equation* - A law giving the quantitative relation between the distance of the object, the image, and the principal focus of the lens (para 2-24.e).

*Emergent ray* - In optics, the term applied to a ray of light leaving an optically dense medium as

contrasted with the entering or incident ray (fig 2-24).

*Emmetropia* - Normal refractive condition of the eyes. A normal eye is termed emmetropic.

*End correction window* - See correction window.

*End play* - Movement of a shaft along its axis. A type of lost motion common to worm and wormwheel assemblies. The error lies in looseness in the bearings at the ends of the shaft or in the ball cap and socket. The result is that the worm can be rotated a small amount without causing rotation of the wormwheel.

*Entrance pupil* - The clear aperture of the objective.

*Equilibrium, equipoise* - Muscular balance of the eyes.

*Erect* - To change an image from an inverted to a normal position. To both revert and invert.

*Erect image* - The image produced by an optical system which is seen with its upper part up. The normal erect image appears as it is seen by/the normal eye. The *reverted erect image* is seen with the right side on the left.

*Erect type* - The image produced by one type of coincidence range finder in which the image appears



normal erect when in coincidence except for the presence of the *halving line*.

*Erecting system* - Lenses or prisms, the function of which is to erect the image, that is, to bring the image upright after it has been inverted by the

objective. An erecting system may consist of one or more lenses (figs B-13 and 4-20), each of which is called an erector, or of one or more prisms (figs 4-21 and 4-11).

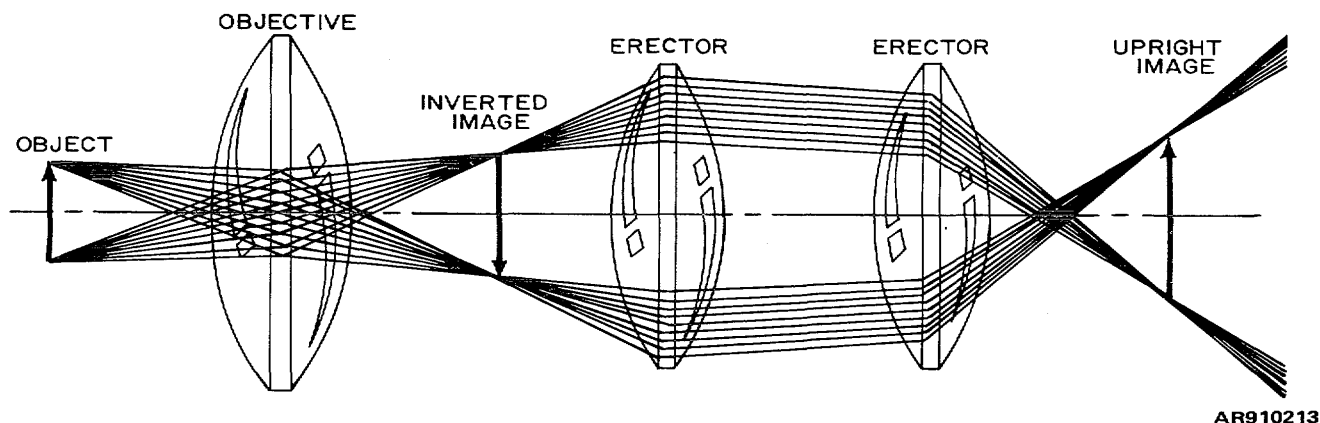

Figure B-13. Lens erecting system.

*Erector* - One of the lenses of a lens erecting system (fig B-13).

*Esophoria* - A condition of the eyes in which the lines of sight tend to turn inward.

*Etching* - The marking of a surface by acid, acid fumes, gas, or a tool. A process extensively used in the manufacture of reticles.

*Exit pupil* - The diameter of the bundle of light leaving an optical system. The small circle or disk of light which is seen by looking at the eyepiece of an instrument directed at an illuminated area (fig 2-53). Its diameter is equal to the entrance pupil divided by the magnification of the instrument.

*Exophoria* - A condition of the eyes in which the lines of sight tend to turn outwardly.

*Extra-foveal vision* - Vision in parts of the retina other than fovea.

*Eye distance or eye relief* - The distance from the rear surface of the eyelens to the plane of the exit pupil (fig 2-55). The center of rotation of the observer's eye should be situated in this plane. The center of rotation of the eye is about 6 millimeters behind the vertex of the cornea.

*Eyeguard* - See eyeshield.

*Eyelens* - The lens of an eyepiece which is nearest to the eye (fig B-14). See eyepiece. Various types of lenses are used for this purpose.

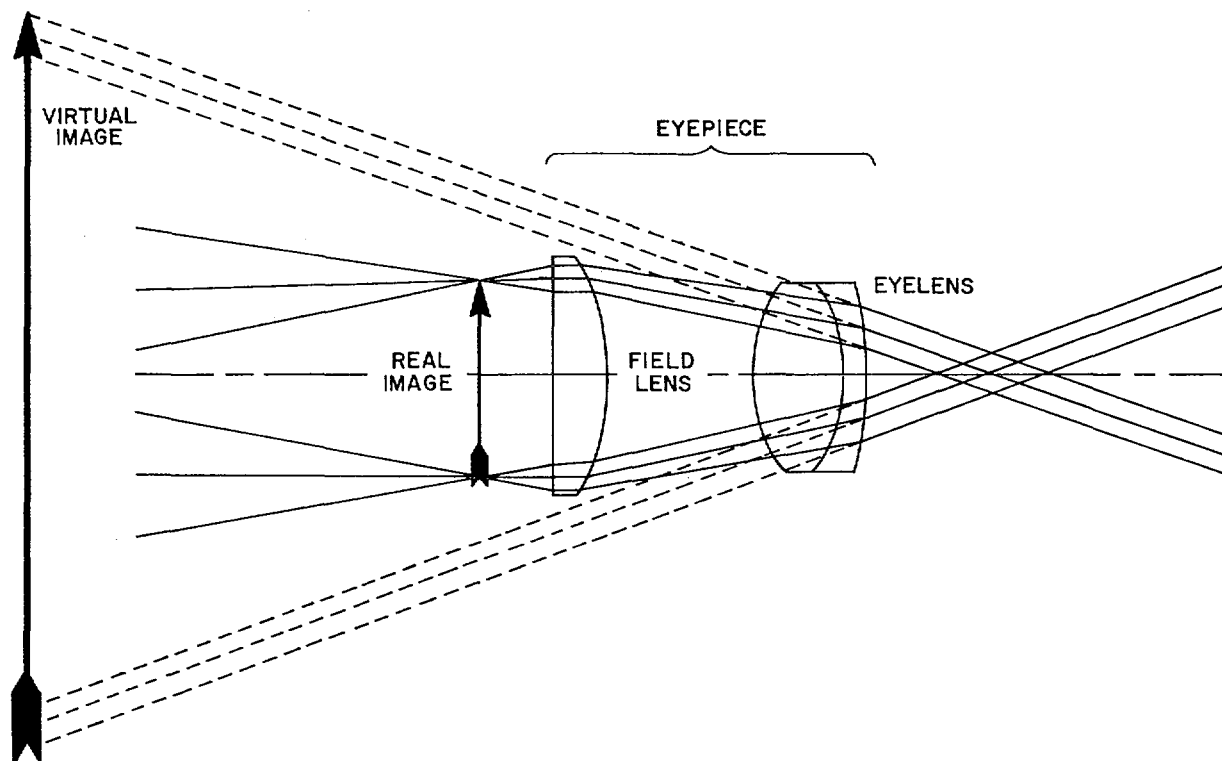

Figure B-14. Eyelens and fields lens of eyepiece.

*Eyepiece* - An optical system used to form a virtual, erect, enlarged image of the real image formed by the objective (fig B-14). The optical system of the eyepiece usually consists of two lenses, an eyelens and a field lens, but the eyepiece may contain another lens (figs 4-5, 4-6 and 4-7).

*Eye relief* - See eye distance.

*Eyeshield or eyeguard* - A shield of rubber plastic, or metal to protect the eyes of the observer from stray light and wind and to maintain proper eye distance.

*Far point* - The farthest point of clear vision of the unaccommodated eye. For the normal eye, the far point is infinity. See infinity.

*Farsightedness* - See hypermetropia.

*Field glass* - A type of compact *binocular*.

*Field lens* - One of the lenses of an eyepiece. It is the lens which is nearest the image upon which the eyepiece is focused. It serves to shorten the eye relief and adds to brightness of the edge of the field (fig B-14).

*Field of view* - The open or visible space or angle commanded by the eye. It

is the maximum angle of view that can be seen at one time. In an instrument, the *true field of view* is the actual angle of view of the instrument, the maximum angle subtended at the objective by any objects which can be viewed simultaneously. The *apparent field of view* is the size of the field of view angle as it appears to the eye; it is approximately equal to the magnifying power of the instrument times the angle of the true field of view (fig 2-52).

*Field stop* - See diaphragm.

*Filters or ray filters* - Colored glass disks with plane, parallel surfaces placed in the path of light through the optical system of an instrument to reduce glare and light intensity and likewise in observing tracer fire and detecting outlines of camouflaged objects. They are provided as separate elements or as integral devices mounted so they may be placed in or out of position as desired (fig 4-27).

*Finite* - Having limits, as opposed to infinite, or without limits.

*Fire control* - The determination and regulation of the direction of gunfire. More specifically, it refers

to the observation and calculations necessary for determining the correct aiming of a weapon system.

*Fixed focus* - The term applied to instruments which are not provided with means for focusing. Such instruments, generally, have a wide range of accommodation which permits them to be used by the majority of observers. Collimator is an example.

*Flint glass* - One of the two principal types of optical glass, the other being crown glass. Flint glass is softer than crown glass, has a higher index of refraction, and higher dispersion. See compound lens.

*Fluorescence* - Phenomenon whereby light of one wavelength is absorbed by a material, and then reemitted as light of a different wavelength. Fluorescent light sources require generally external white light to cause them to become luminous and glow with a colored hue. They cease to become luminous when the exciting agent is removed.

*Focal length* - The distance from the principal focus (focus of parallel rays of light) to the surface of a mirror or the optical center of a lens (figs 2-44, 2-45, 2-46 and B-15)

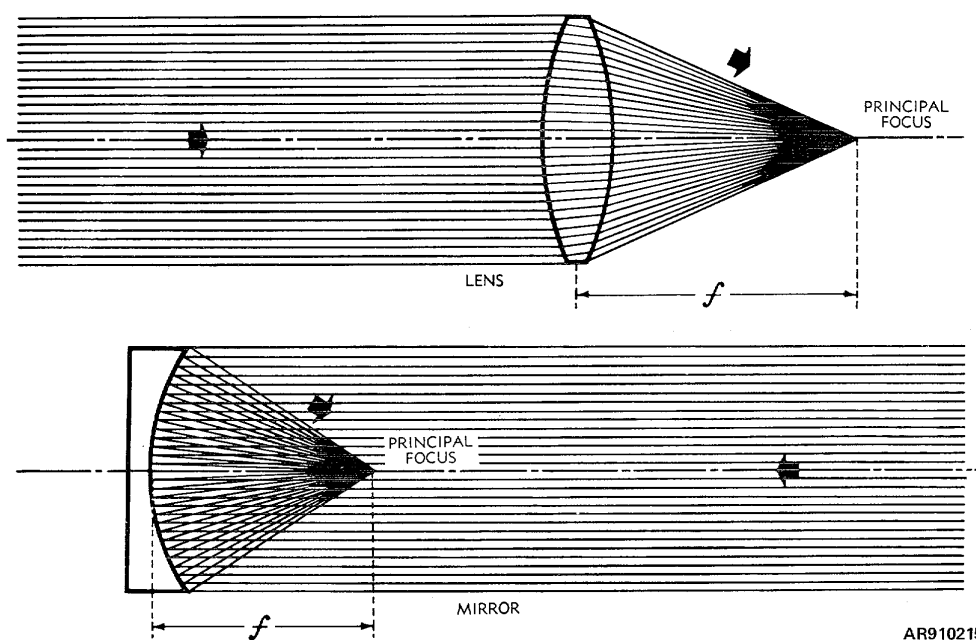

Figure B-15. Focal length of lens and mirror.

*Focal plane* - A plane through the focal point perpendicular to the principal axis of a lens or mirror (fig 2-44).

*Focal point* - The point to which rays of light converge or from which they diverge when they have been acted upon by a lens or mirror (figs 2-46 and 2-62). A lens has many focal points, depending upon the distance of the object from the lens.

*Focus* -

a. To adjust the eyepiece of a telescope so that the image is clearly seen by the eye or to adjust the

lens of a camera so that a sharp, distinct image is seen on the ground glass.

b. The process of adjusting the distances between optical elements to obtain the desired optical effect.

c. Same as focal point.

*Focusing nut* - A threaded nut in the center of which the eyepiece of a telescope is attached to permit the eyepiece to be moved in or out to accommodate the instrument to eyesight variations. It

usually carries a *diopter scale* to permit presetting of the instrument (fig 4-38).

*Focusing sleeve* - A knurled sleeve which is rotated to shift the positions of the erectors with relation to the objective and eyepiece to focus the instrument or to change its magnification.

*Foot-candles* - A unit of measurement of the intensity of illumination. A foot-candle is the amount of light intensity received on a surface 1 foot away from a light source of one candle power, such as a standard candle of sperm whale oil, 7/8 inch in diameter, burning at the rate of 120 grains per hour.

*Fovea or fovea centralis* - A tiny area of cones in the center of the macula or the yellow spot of the retina of the eye. It is the area of the eye responsible for the clearest vision. It is about 0.25 millimeter in diameter, and contains cones only.

*Freedom from defects* - Optical glass which is homogeneous and free from bubbles or striae (localized variations in the index of refraction).

*Freedom from distortion* - An image that is a true reproduction of the object.

*Frequency* - In light or other wave motion, the number of crests of waves that pass a fixed point in a given unit of time, usually 1 second.

*Front surface mirror* - An optical mirror on which the reflecting coating is applied to the front surface of the mirror instead of to the back.

*Fuse* - In stereoscopic vision, the action of seeing as one image the images seen by the two eyes.

*Fusion* - The mental blending of the right and left eye images into a single, clear image by stereoscopic action.

*Galilean telescope* - One of the first telescope models, utilizing a positive objective lens and diverging eyelens (figs 5-13 and 5-14).

*Gauss - objective* See dialyte.

*Gear train* - Two or more gears meshed together so that rotation of one causes rotation of the others.

*Geometrical center* - As applied to lenses, the physical center of the lens as determined by measurement; sometimes referred to as the mechanical center to distinguish it from the optical center.

*Ghost image* - A hazy second image caused by reflection sometimes seen in observing through a telescope.

*Gimbal joint* - A mechanism which permits rotation around two perpendicular axes or for suspending an object so that it will remain vertical or level when its support is tipped.

*Grid declination* - The angle between True North and Y-North.

*Grid North* - See Y-North.

*Gunner's quadrant* - An instrument with a

graduated arc, used in range adjustment. It measures the angle of elevation of the gun.

*Halving line* - The line which divides the two half images in a coincidence type range finder. The two halves of the images produced by the two objectives of the instrument must be brought to a point where they match or coincide above and below the halving line.

*Hard coat* - The term applied to the coating of magnesium fluoride on coated optics to differentiate between other softer coatings which are less durable.

*Height of image adjuster* - A glass plate with plane surfaces which is tipped one way or the other in the line of sight in one of the internal telescopes of a range finder. It deviates the light slightly upward or downward to adjust the image of one eyepiece to the same height as the image visible in the other eyepiece.

*Heterophoria or muscular imbalance* - Any disturbance of the power, strength, or nervous system of the eye muscles which does not permit both eyes to function together in a normal way. It may occur in any of a number of different forms such as esophoria in which the lines of sight tend to turn inwardly, esophoria in which they tend to turn outwardly, and hyperphoria in which the line of sight of one eye tends to be above that of the other.

*Homogeneity* - Being uniform throughout.

*Homogeneous* - Uniform throughout; composed of similar parts.

*Horizontal travel* - Rotation of an instrument (or the line of sight of an optical instrument) in a horizontal plane; traverse; movement in azimuth.

*Hypermetropia* - An eye defect in which the image tends to be focused beyond the retina with the result that the image is blurred and indistinct, farsightedness. It is caused by the refracting surfaces of the eye being too slightly curved, by the eye being of insufficient depth, or by the decline in the power of accommodation in viewing nearby objects. It is corrected by a converging lens (fig 3-11).

*Hyperopia* - See hypermetropia.

*Hyperphoria* - A condition of the eyes in which the line of sight of one eye tends to be above that of the other.

*Hyperphoric displacement* - Action of the eyes necessary to obtain fusion in observing through a stereoscopic or binocular instrument when the image seen by one eye is above that seen by the other eye.

*Iceland spar, calcite* - A mineral that has the faculty of polarizing light.

*Illuminated* - Lighted by another source than

itself, as opposed to a luminous body, which is a light source.

*Image* - A reproduction or picture of an object produced by light rays. An image-forming optical element produces an image by collecting a beam of light diverging from an object point and transforming it into a beam which converges toward, or

diverges from, another point. If the beam converges to a point, a real image is produced (fig 2-47); if the beam diverges, a virtual image is produced at its apparent source (fig 2-47). A real image can be thrown upon a screen (fig 2-47); a virtual image exists only in the mind of the observer.

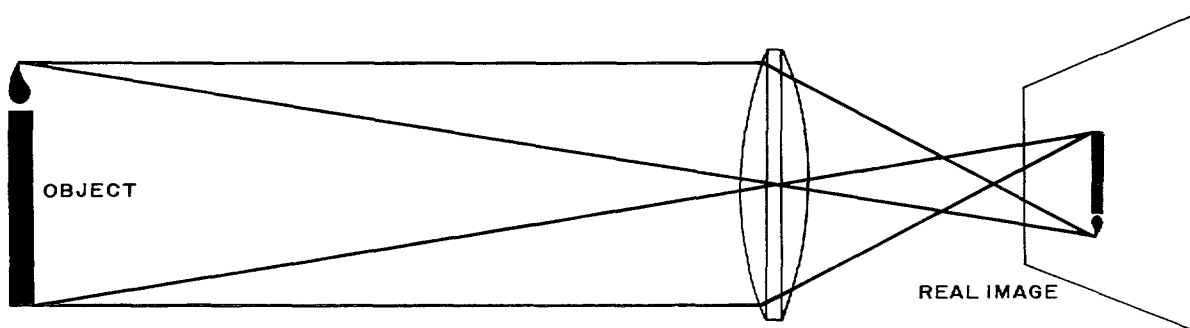

AR910216

Figure B-16. Virtual image produced by diverging lens .

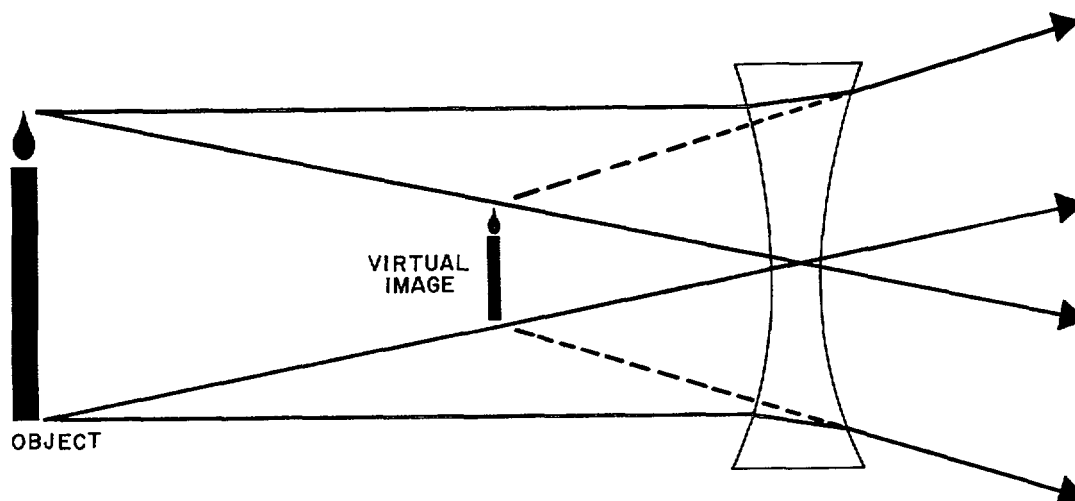

AR910217

Figure B-17. Virtual image produced by diverging lens .

*Image plane* - The plane in which the image lies or is formed. It is perpendicular to the axis of the lens and is at the focal point. A real image formed by a converging lens would be visible upon a screen placed in this plane (fig 2-46).

*Imbalance* - See Heterophoria.

*Incandescence* - The state of a body in which its temperature is so high that it gives off light.

Examples: the sun or the filament of an electric lamp.

*Incidence* - The act of falling upon, as light upon a surface.

*Incident ray* - A ray of light which falls upon or strikes the surface of an object such as a lens or mirror. It is said to be incident to the surface (figs 2-13 and 2-24), as contrasted with the ray leaving an optically dense medium or emergent ray.

*Index (plural, indices)*

a. An arrow or mark against which a

calibration, graduation, or scale is set to indicate the extent to which a mechanism is adjusted; something that points out.

b. The ratio of one dimension or quantity to another.

*Index of refraction* - A number applied to a transparent substance which denotes how much faster light will travel in a vacuum than through that particular substance. It is equal to the ratio between the speed of light 'in a vacuum to the speed of light in a substance. It determines the relation between the *angle of incidence* (i) and the *angle of refraction* (r) when light passes from one medium to another (figs 2-24 and B-18). The index between two media is called the *relative index*, while the index when the first medium is a vacuum is called the absolute index of the second medium. The relative index is the ratio of the sine of the angle of incidence to the sine of the angle of refraction, or the speed of light in the first medium to the speed of light in the second medium. If the first medium is air, this relation is expressed as -

$$n \sin r = \frac{\text{Speed of light in air}}{\text{Speed of light in other medium}}$$

(Snell's law)

where n equals very nearly the absolute index of refraction, i equals the angle of incidence, and r equals the angle of refraction.

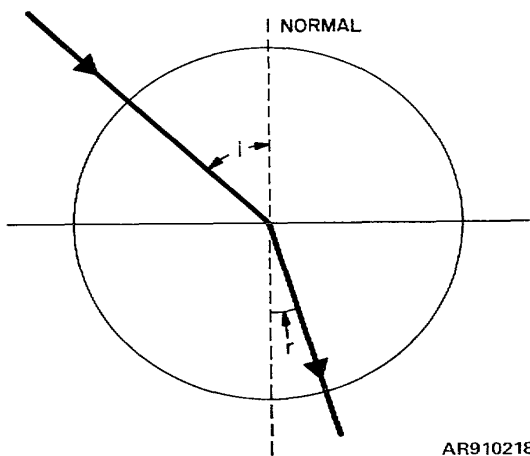

Figure B-18. Index of refraction

**NOTE**

The index of refraction expressed in tables is the absolute index, that is, vacuum to substance at a certain temperature, with light of a certain wavelength. Examples: vacuum, 1.00; air, 1,000293; water 1.333; ordinary crown glass, 1.517. Since the index of air is very close to that of vacuum, the two are often used interchangeably as being practically the same.

*Infinite* - Without limit, as opposed to finite, meaning with limits.

*Infinity* - Distance having no end or limits. Greater than any assignable distance or quantity. In optics, the term is used to denote a distance sufficiently great so that light rays coming from that distance are practically parallel to one another. Infinity is indicated by the symbol ∞

*Infrared radiation* - Electromagnetic radiation whose wavelength lies just beyond the red end of the visible spectrum, and the beginning of the region that can be detected by microwave radio techniques.

*Interpupillary* - Between the pupils of the eyes.

*Interpupillary adjustment* - The adjustment of the distance between the eyepieces of a binocular instrument to correspond with the distance between the pupils of the eyes of an individual.

*Interpupillary distance* - The distance between the centers of the pupils of the eyes. It is generally stated in millimeters. It varies with the individual.

*Inversion* - Turned over; upside down so that top becomes bottom and vice versa. It is the effect produced by a horizontal mirror in reflecting an image.

*Invert-type Image* - The type of image observed in certain coincidence range finders. When in coincidence, the upper half image appears to be the mirrored reflection of the lower half image.

*Inverted image* - Turned over; upside down. An image, the top of which appears to be the bottom of the object and vice versa. Usually refers to the effect of a mirror, a prism, or lens upon the image.

Inversion is the effect of turning upside down. A plane mirror held under an object will produce an inverted image. The normal inverted image is seen upside down, with the right side on the right. The reverted inverted image is seen upside down with the right side on the left.

*Iris* - The colored part of the eye about the pupil. Depending upon the intensity of light, the iris causes the pupil to dilate or contract.

*Jack screw* - A screw threaded through one part and pressing against another. A jack (portable machine) in which a screw is used for lifting or for exerting pressure.

*Laser* - Acronym for light amplification by stimulated emission of radiation.

*Law of reflection* - The angle of reflection is equal to the angle of incidence; the incident ray, reflected ray, and normal all lie in the same plane (fig 2-13).

*Law of refraction* - When light is passing from an optically lighter medium to an optically denser medium, its path is deviated, toward the normal; when passing into an optically less dense medium,

its path is deviated away from the normal (fig 2-24).The amount of deviation is determined by means of the equation for the index of refraction for the two media involved. See index of refraction.

*Law of relative size of object and image* - The size of the image is to the size of the object as the image distance from the lens or mirror is to the object distance.

*Law of reversibility* - If the direction of light is reversed, it will travel in the opposite direction over the same path despite the number of times it is reflected or refracted.

*Lens* (plural, lenses) - A transparent object, usually a piece of optical glass, having two polished surfaces of which at least one is curved, usually with a spherical curvature. It is shaped so that rays of light, on passing through it, are made to converge or diverge. The fact that lenses either converge or diverge rays provides one means of classification, the type of curvature provides another (fig 4-1), the corrections made in the lens provides still another. The term lens may be employed to mean a compound lens which can consist of two or more elements. See achromatic lens, anastigmat, aplanatic lens, apochromatic lens, astigmatizer, collective lens, compound lens, concavo-convex lens, converging

lens, convexo-concave lens, corrected lens, cylindrical lens, dialyte, diverging lens, double-concave lens, double-convex lens, doublet erector eyelens, field lens, meniscus-converging lens, meniscus diverging lens, minus lens, objective, orthoscopic lens, plano-concave lens, planoconvex lens, plus lens, and triplet.

*Lens cell* - A number of lenses mounted as a unit in a tubular mounting frame.

*Lens diopter* - See diopter.

*Lens equation, elementary* - The equation giving the relation between the distances from the optical center of the lens of the object (Do), the image (Di), and the principal focus (F). These values are related as

$$\frac{1}{D_o} \text{ plus } \frac{1}{D_i} \text{ equals } \frac{1}{F}$$

*Lens erecting system* - See erecting system.

*Lens retaining ring* - See retaining ring.

*Lens system* - Two or more lenses arranged to work in conjunction with one another (fig B-19). When in proper alignment, the principal axes will be coincident and the system can be referred to as a "centered lens system."

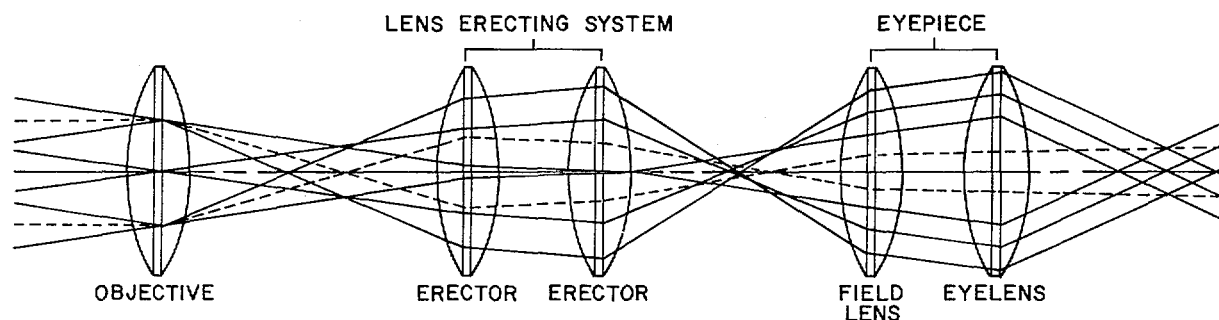

AR910219

Figure B-19. Optical system of erecting telescope .

*Lenses of the eye* - The refractive elements of the eye. See cornea and crystalline lens.

*Light-adapter* - A term applied to the adjustment of the visual cells of the retina of the-eye for the clearest and most distinct 'sight under good lighting conditions. It applies to the process whereby the cones of the retina take over the major portion of the act of seeing.

*Light ray* - The term applied to the radii of waves of light to indicate the direction of travel of the light. Light rays are indicated by arrows and lines (fig 2-5).

*Limiting angle of resolution* - The angle subtended by two points which are just far enough apart to permit them to be distinguished as separate points. It is commonly used as a measure of resolving power.

*Limits of accommodation* The distances of the nearest and farthest points which can be focused clearly by the eyes of an individual. Usually varies from 4 to 5 inches to infinity. See accommodation.

*Line of elevation* In artillery, the line of the axis of the bore of a gun when it is in firing position (fig B-3).

*Line of position* - See line of site.

*Line of sight* - Line of vision; optical axis of a telescope or other observation instrument. Straight line connecting the observer with the aiming point; the line along which the sights are set in a gun, parallel to the axis of the bore (fig B-6).

*Line of site* A straight line extending from a gun or position-finding instrument to a point, especially a target (fig B-3). Usually called line of position.

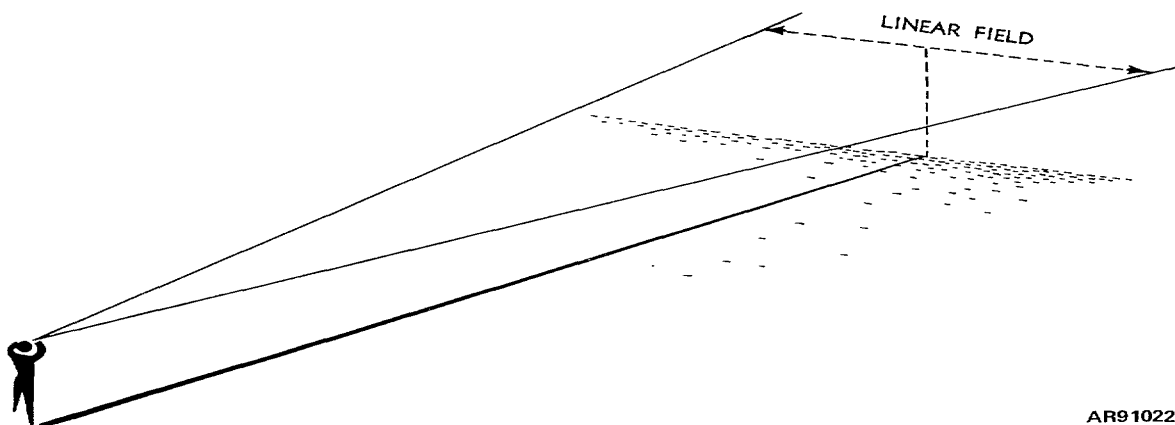

AR910220

Figure B-20. Linear field

*Lost motion* - Motion of a mechanical part which is not transmitted to connected or related parts. It is the cumulative result of backlash and end play.

*Lumen* - The amount of light falling on an area of 1 square foot, at 1 foot distance from a standard candle. See standard candle.

*Luminescence* - Giving off light at a temperature below that of incandescence. The radiating of "cold" light as seen from fireflies or luminous paint.

*Macula or yellow spot* - A small area of the retina of the eye which is highly sensitive to light and which is the zone of the clearest and most distinct vision except for a much smaller area at its center known as the fovea or fovea centralis. The macula is about 2 millimeters in diameter, and contains principally cones and only a few rods (fig 3-2).

*Magnesium fluoride* - See hard coat.

*Magnetic azimuth* - Azimuth measured from Magnetic North.

*Magnetic declination* - The angle between True North and Magnetic North

*Magnetic-grid declination* - The angle between Magnetic North and Grid North (Y-North).

*Magnetic needle* - A magnetized needle used in a compass. When freely suspended, it will assume a position parallel to the earth's magnetic lines of force which connect the magnetic poles.

*Magnetic North* - The direction of the earth's north magnetic pole as indicated by the north-seeking end of a magnetic needle.

*Magnification* - The increase in the apparent size of an object produced by an optical element or instrument.

*Magnifying power* - The ability of a lens, mirror, or optical system to make an object appear larger (fig B-21). If an optical element or optical system makes an object appear twice as high and twice as wide, the element or system is said to have a magnification of 2-power. The power of an optical instrument is the diameter of the entrance pupil divided by the diameter of the exit pupil, the focal length of the objective divided by the focal length of the eyepiece, or the apparent field of view divided by the true field of view



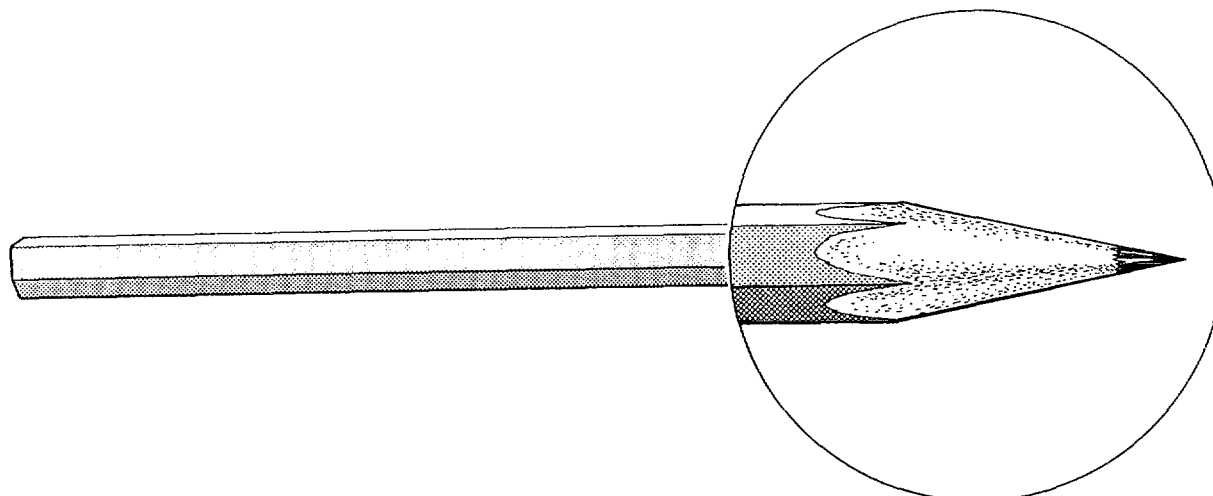

AR910221

Figure B-21. Magnifying power .

*Marginal rays* - Rays of light near the edge of a lens.

*Maser* - Acronym for microwave amplification by stimulated emission of radiation.

*Measuring wedge* - An optical element employed in a range finder to deviate or displace light entering the variable angle end of the instrument. One type consists of a single, perpendicular wedge which is moved in alignment with the path of light to shift or displace the light (fig 4-18). The other type consists of one or two pairs of circular wedges, each pair being capable of rotating equally and simultaneously in opposite directions about the axis of the path of light to produce variable deviation (fig 4-19). The wedges of both types are compound elements corrected for color.

*Medium* (plural, media) - Any substance or space.

*Meniscus* - A lens the surfaces of which are curved in the same direction.

*Meniscus converging lens* - A lens the surfaces of which are curved in the same direction; one surface is convex, the other is concave. The convex surface has the greater curvature or power (fig 4-1). Spectacle lenses of this type are used to correct farsightedness, hypermetropia, or hyperopia (fig 3-11).

*Meniscus diverging lens* - A lens the surfaces of which are curved in the same direction; one surface is convex, the other is concave. The concave surface has the greater curvature or power (fig 4-1). Spectacle lenses of this type are used to correct nearsightedness, myopia (fig 3-10).

*Micrometer* - A mechanism for measuring small angles or dimensions. On optical instruments it is the "fine" scale.

*Micrometer scale* - An auxiliary scale used to read small angles or dimensions.

*Micromicron* - A unit of measure equalling one-millionth part of a micron.

*Micromillimeter* or *millimicron* - Terms applied to unit of measure equal to one-millionth part of a millimeter or one-thousandth part of a micron.

*Microna* - A unit of measure equaling one-millionth part of a meter or one-thousandth part of a millimeter.

*Mil (Artillery Mil)* - A unit of angular measurement used in Army military calculations. It is 1/6400th of a complete circle or very nearly the angle between two lines which will enclose a distance of 1 meter at a range of 1,000 meters or 2 meters at a range of 2,000 meters (fig 10-2). 17.78 mils is approximately equal to 1 degree.

#### NOTE

The Navy mil and the French infantry mil enclose exactly 1 meter at a range of 1,000 meters. There are 6283.1853 Navy or French infantry mils in a complete circle.

*Minus lens* - A diverging lens. A lens with negative focal length (focal point toward the object).

*Minute* - A unit of measurement of an angle equal to one-sixtieth of a degree.

*Mirror* - A smooth, highly polished surface for reflecting light. It may be plane or curved. Usually a thin coating of silver or aluminum on glass constitutes the actual reflecting surface. When this surface is applied to the front face of the glass, the mirror is termed a front surface mirror.

*Monochromatic* - Composed of one color.

*Monocular* - Pertaining to vision with one eye.

A term applied to optical instruments requiring the use of only one eye

*Mount* - A device for attaching or supporting an optical instrument. It may be may not be provided with means for elevating and traversing the instrument, calibrations to indicate degree of movement, and means and gages for leveling. This term is applied also to means of securing an optical element in an instrument.

*Muscular imbalance* - See heterophoria.

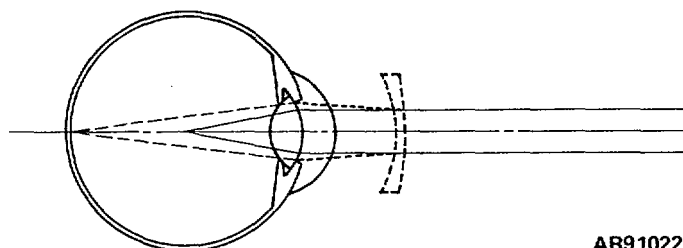

AR910222

Figure B-22. Nearsightedness (myopia) .

*Navy mil* - See mil.

*Near point* - Closest point of clear vision with the unaided eye.

*Nearsightedness* - See myopia.

*Negative lens* - See diverging lens.

*Newton's rings* - A series of concentric colored or bright and dark circles seen when positive and negative (convergent and divergent) surfaces of nearly the same curvature are pressed together. It is caused by interference of light rays. The more nearly the surfaces are matched, the greater the distance between the rings and the larger and more regular the circles (fig 2-70).

*Night blindness* - A condition of the eyes (and possibly the health) of a person which does not permit him to see as well at night or with poor illumination as the average person.

*Night glasses* - An optical instrument for use at night having an *exit pupil* at least 7 millimeters.

*Normal* - An imaginary line forming right angles with a surface or other lines, the perpendicular. It is used as a basis and reference line for determining angles of incidence, reflection, and refraction. In figure B-23, the normal is perpendicular or at right angles to all lines lying in the plane and passing through point O.

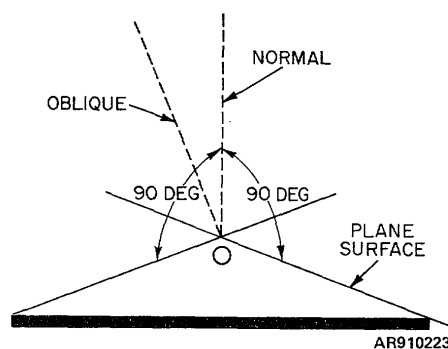

AR910223

Figure B-23. Normal and oblique .

*Normal erect* - See erect image.

*Normal inverted* - See inverted image.

*North* - See Magnetic North, True North, Y-North (Grid North).

*Object* - The principal thing imaged by the optical system. It may be part of large object, an entire object plus its immediate surroundings, or a number of objects. It is a general term used for the sake of convenience.

*Object distance* - The distance of an object from the eyes or from an optical system.

*Objective* - The lens in an optical system which receives light from the field of view and forms the first image. It is the lens farthest from the eye and nearest the object viewed.

*Objective cap* - A protective device, usually made of leather, which is placed over the objective end of the instrument when the instrument is not in use (fig 4-37).

*Objective prism* - A right-angle prism employed in some types of instruments to bend light 90° before it enters the objective system (fig 4-22).

*Oblique Slanting*; neither at right angles nor parallel (fig B-23)

*Ocular* -

1. A term sometimes applied to the eyepiece.
2. Pertaining to, connected with, or used for the eyes or eyesight.

*Ocular prism* - The prism employed in a range finder to bend the line of sight through the instrument into the eyepiece.

*Off-carriage instruments* - Those instruments used in artillery which are not mounted on the carriage of the weapon such as the aiming circle, BC periscope, and range finder.

*Offset* - See prism offset.

*Oldsightedness* - See presbyopia.

*On-carriage instruments* - Those instruments used in artillery which are mounted directly on the carriage of the weapon such as panoramic and elbow telescopes and their associated telescope mounts.

*Ophthalmic* - Pertaining to the human eye.

*Optic nerve* - Nerve connecting the eye and the optic centers of the brain.

*Optical* - Pertaining to vision and the phenomenon of light.

*Optical axis* - The line formed by the coinciding principal axes of a series of optical elements comprising an optical system; in other words, an imaginary line passing through the optical centers of the system.

*Optical center* - Point in a lens on a line connecting all focal points, peculiar in that it is a point through which the rays of light pass and emerge parallel to their path of incidence (fig 2-45). It is in the geometric center of the thickest part of a converging (convex) lens and of the thinnest part of a diverging (concave) lens.

*Optical characteristics* - Those properties of an optical system which it possesses by reason of its optical or visual nature such as field of view, magnification, brightness or image, and freedom from distortion.

*Optical element* - A part of an optical instrument which acts upon the light passing through the instrument such as a lens, prism, or mirror.

*Optical glass* - Glass carefully manufactured to obtain purity, transparency, homogeneity, and correct optical properties. See crown glass and flint glass.

*Optical properties* - In optical glass, those properties which pertain to the effect of the glass upon light such as index of refraction, dispersion, homogeneity, and freedom from defects.

*Optical surface* - A reflecting or refracting surface.

*Optical system* - A number of lenses, or lenses and prisms, or mirrors, so arranged as to refract, or reflect and reflect light, to perform some definite optical function (fig B-19).

*Optics* - That branch of physical science which is concerned with the nature and properties of light, related instruments, and vision.

*Orbit* - The socket of the human eye.

*Orient* - In fire control, to find the proper bearing; to fix the position of a gun, with reference to a predetermined target point.

*Orientation* - Determination of the horizontal and vertical location of points and the establishment of orienting lines, adjustment of the azimuth circle of a weapon or instrument to read required azimuths, and adjustment of the vertical quadrant angle of elevation (angle of site plus angle of elevation) to required values.

*Orthophoria* - A term used with reference to the eyes indicating that both eyes are equally and properly controlled by eye muscles with the result that, with the eyes at rest, they focus and converge upon a distant object.

*Orthoscopic eyepiece* - An eyepiece which has been corrected for distortion, particularly that type of eyepiece having a triple element cemented field lens and a planoconvex or meniscus converging eyelens (paras 2-24i, 4-4k, and B, fig 4-7). See eyepiece.

*Orthoscopic lens* - A lens which has been corrected for distortion, giving an image in correct or normal proportions, with a flat field of view (para 2-24i).

*Panoramic telescope* - A telescope so designed that the image remains erect and the position of the eyepiece is unchanged as the line of sight is pointed in any horizontal direction.

*Parabolic mirror* - A concave mirror which has the form of a special geometrical surface; a paraboloid of revolution. Light rays emanating from a source located at the focal point of the paraboloid are reflected as parallel rays. Most searchlights are of this design. All light rays which are parallel and strike the mirror directly from the front are reflected towards the focal point (fig 2-21).

*Parallactic angle* - In range finding, the angle at the target subtended by the base length. The

baseline of the range finder forms the base of a triangle and its apex is the target (fig. 8-28). Corresponds to the angle of convergence in stereoscopic vision (fig. 3-8 and 3-9).

*Parallax* - Any apparent displacement of an object due to the observer's change of position such as in A, figure 2-72, where the observer will see either the pole number 4, or pole 7 positioned opposite the mountain, if he changes his position. This illusion of a relative displacement of the poles with respect to the mountain is a deception, inasmuch as neither the poles nor the mountain actually move. Optically, parallax in a telescope with a reticle is any apparent movement of the reticle in relation to distant objects in the field of view caused by movement of the head of the observer. This condition exists when the image in the telescope lies in one focal plane and the reticle lies in another (B, fig 2-72).

*Paraxial pencil* - A narrow group of light rays along the axis.

*Paraxial ray* - Any ray parallel to the axial ray in a pencil of light. A ray in the immediate neighborhood of the optical axis of a lens or mirror or close to its center.

*Patina* - A film. Surface mellowing or softening. A film or oxide formed on copper and bronze.

*Pechan or Z-Rotating prism* - Used as a rotating prism. It is used to invert the image in one plane without deviating or displacing the axis of the rays of light. Used as the rotating prism in the conventional type of optical system of panoramic telescopes (B, fig 4-13).

*Pencil of light* - A narrow group of light rays coming from a point source or converging toward a point. A pinhole opening produces a pencil of rays.

*Pentaprism* - A five-sided prism used to bend light through a constant angle, usually 90 degrees, without producing inversion or reversion if reflection takes place in the vertical or horizontal plane (fig.4-14).

*Peripheral* - On the circumference. Near the boundary or edge of the field of an optical system; the outer fringe.

*Periscope* - An optical instrument designed to displace the line of sight in a vertical direction usually upwards. Used to permit observation over the top of a fortification, a barricade, or out of a tank (fig 8-19).

*Persistence of vision* - The mental effect of an

impression registered upon the retina and the optic nerve remaining for about 1/15 second after the stimulus has been removed.

*Perspective* - Appearance in terms of distance. Example, railroad tracks which appear to converge as they are seen receding in the distance. Appearance in relief, in three dimensions.

*Phosphorescence* - The glowing or giving off of light without sensible heat; the property to shine in the dark due to emission of light caused by chemical reaction, as fireflies.

*Photon* - A quantum (elemental unit) of radiant energy.

*Plane* - A surface which has no curvature; a perfectly flat surface.

*Planoconcave lens* - A lens with one surface plane; the other concave.

*Planoconvex lens* - A lens with one surface plane; the other convex.

*Plumbline* - A vertical line. When used for adjusting instruments, it is a weight (plumb bob) hanging on a string.

*Plus lens*- A converging (convex) lens.

*Point of fixation* - The object on which the optical instrument is focused; an object on which the observer's eye is concentrated.

*Point of principal focus* - The point to which parallel rays of light converge or from which they diverge when they have been acted upon by a lens or mirror (figs 2-19, 2-44, and 2-46). A lens has two points of principal focus, one on each side of the lens. A lens has many focal points depending upon the distance of the object from the lens (fig 2-47).

*Polarized light* - In optics, the light which vibrates in one direction only (in a single plane).

Plane of polarization is the plane in which the polarized light vibrates. Light is polarized by natural materials (Iceland spar) or a manufactured product known as "Polaroid" or when being reflected, at a glancing angle from a smooth surface.

*Polarizing filter* - A light ray filter which polarizes the light passing through an instrument.

*Porro prism* - One of two identical prisms (fig B-24) used in the Porro prism erecting system (fig 4-9). It is a right angle prism with the corners rounded to minimize breakage and simplify assembly. See porro prism erecting system (fig 4-9).

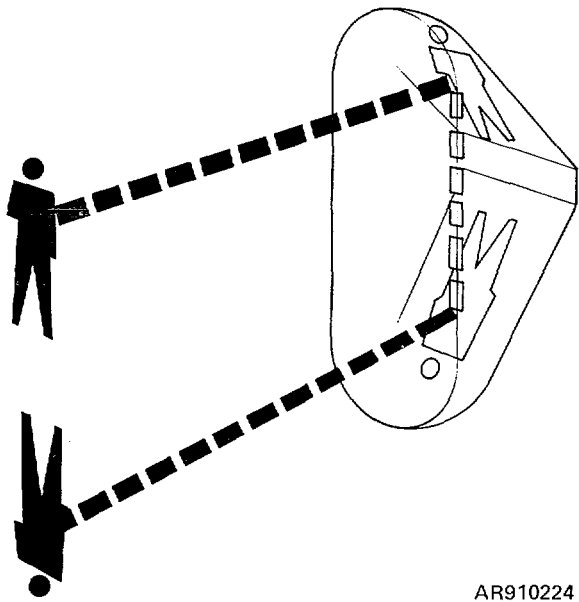

AR910224

Figure B-24. Porro prism .

**Porro prisms erecting system** A prism erecting system, designed by M. Porro, in which there are four reflections to completely erect the image. Two Porro prisms are employed (fig 4-9). The line of sight is bent through 360°, is displaced, but is not deviated.

**Positive lens** - See converging lens.

**Power** -

1. In a prism or a lens, power is a measure of ability to bend or refract light. It is usually measured in diopters. See diopter and prism diopter.

2. In a telescope, power is the number of times the instrument magnifies the object viewed. For example, with a 6-power instrument, an object 600 yards away is enlarged six times or it appears as it would to the naked eye if it were at a distance of only 100 yards.

**Presbyopia** - A defect of vision due to advancing age, "oldsightedness". The crystalline lens no longer is capable of accommodating for nearby objects and these objects cannot be seen distinctly. It is corrected by the use of convex lenses.

**Principal axis** - A straight line about which an optical element or system is symmetrical. A straight line connecting the centers of curvature of the two refracting surfaces of a double convex lens. In a mechanical sense, a line joining the centers of the two surfaces of a lens as it is placed in the mount.

**Principal focal plane** - Plane perpendicular to the axis through the point of principal focus (figs 2-44 and 2-46).

**Principal focal point** - See point of principal focus.

**Principal focus** - See point of principal focus.

**Prism** - A transparent body with at least two polished plane faces inclined toward each other from which light is reflected or through which light is refracted. When light is refracted by a prism, it is deviated or bent toward the thicker part of the prism (fig B-25). See Abbe prism erecting system, Amici prism, coincidence prism, Dove prism, objective prism, Pechan prism, pentaprism, Porro prism, rhomboidal prism, right-angle prism, and triple mirror.

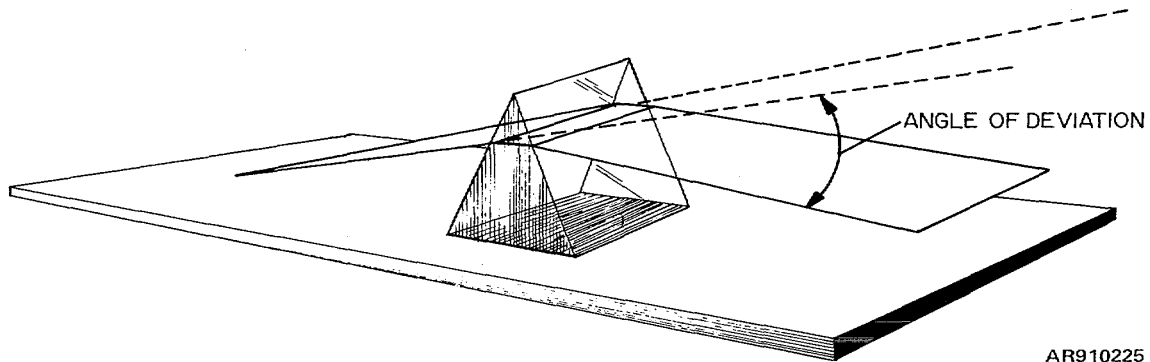

AR910225

Figure B-25. Prism .

**Prism diopter** A unit of measure of the refracting power of a prism. One diopter is the power of a prism to deviate a ray of light by one centimeter at a distance of one meter from the prism.

**Prism erecting system** - See erecting system.

**Prism offset** - The term applied to certain telescopes having a characteristic offset due to the

mounting of the prism erecting system in the body of the instrument.

**Prismatic** - Pertaining to a prism or the effects produced by prisms.

**Probable error** - An allowance based on average errors made by a large group of range finder

operators. It will be exceeded as frequently as it is not.

*Protractor* An instrument for measuring or laying off angles. It consists of a graduated arc or

semicircle, sometimes containing a radial arm (fig B-26). The graduations can be Artillery mils, Navy mils, or degrees. See mil.

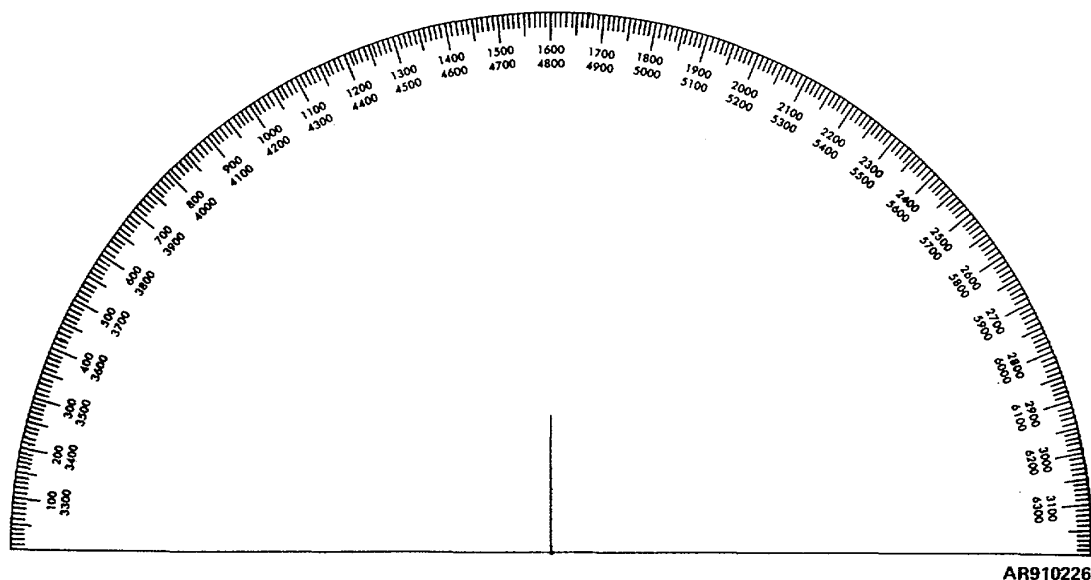

AR910226

Figure B-26. Protractor .

*Pupil* - The dark center of the eye. It is the aperture through which light enters the eye.

*Quadrant* -

1. A quarter of a circle: a sector, arc, or angle of 90 degrees.

2. An instrument for measuring or setting vertical angles such as a gunner's quadrant or a range quadrant.

*Quadrant angle of elevation* - The angle between the horizontal and the line of elevation or axis or bore (fig. B-3). See angle of elevation and angle of site.

*Quanta or Quantum* - See photon.

*Radian* - An angle included within an arc equal in length to the radius of a circle. It is equal to 57°, 17 minutes, and 44.8 seconds.

*Radiant energy* - Energy that is radiated or thrown off in all directions by its source. Light is a form of radiant energy. Energy, by definition, is capacity for performing work.

*Ramsden dynameter* - See dynameter.

*Range Distance*. - The horizontal distance from a gun to its target; the distance from an observer to a designated object. Range usually is measured in meters.

*Range finder* - An optical instrument used to determine the distance of an object or target by

triangulation which is performed mechanically and optically.

*Range quadrant* - An instrument used to set range or measure vertical angles of elevation in laying a gun.

*Ray* - See light ray.

*Ray filter* - See filters.

*Real image* - See image.

*Rectilinear* - In a straight line. When applied to a lens, it indicates that images of straight lines produced by the lens are not distorted.

*Rectilinear propagation* - Straight line travel; refers to the fact that light travels in a straight line when traveling through a medium of constant optical density.

*Reduction* - The decrease in the apparent size of an object produced by an optical element or instrument.

*Reflected ray* - The ray of light leaving a reflecting surface representing the path of light after reflection (fig 2-13).

*Reflection* - Light striking a surface and returning or "bouncing back" into the medium whence it came. Regular reflection (figs 2-13 and 2-15) from a plane polished surface, such as a mirror, will return the major portion of the light in a definite direction lying in the plane of the incident ray and

the normal. See angle of reflection. Regular reflection will form a sharp image. *Diffuse reflection* (fig 2-16) occurs when the surface is irregular and the reflected light diverges from each point as if it were a separate reflecting surface. Diffused rays are scattered, go in many directions, and will not form a distinct image.

*Refracted ray* - The ray of light passing through and leaving a refracting surface representing the path of light after refraction (fig 2-24).

*Refracting power* - The power of a lens or lens system to converge or diverge light. See diopter.

*Refraction* - The bending of light which occurs when a ray of light passes obliquely from one medium to another of different optical density. See angle of refraction and angle of deviation.

*Refractive index* - See index of refraction.

*Regular reflection* - See reflection.

*Relief* - Effect of stereoscopic or three dimensional vision; solidity or depth; sharpness of outline due to contrast of the object standing out, from a background.

*Resolution* - In optics, the ability of a lens system to reproduce an image in its true sense. Forming separate images of two objects or points very close together.

*Resolving power* - A measure of the ability of a lens or optical system to form separate images of two

objects or points close together. No lens or optical system can form a perfect image of a point; it will appear as a small disk surrounded by concentric circles. If two points are so close together that the disks overlap, the points cannot be distinguished separately; they are not resolved. The measure of the resolving power is the angle subtended at the optical center of the lens by two points which are just far enough apart to permit resolution into two separate images. This angle is termed the *limiting angle of resolution*.

*Retaining ring* - A thin ring threaded on the outside surface. It is screwed into a tube, cell, or other body member of an optical instrument to retain or hold a lens or other part in fixed position.

*Reticle* - Marks or patterns placed in the focal plane of the objective of an optical instrument which appear to the observer to be superimposed upon the field of view (fig B-27). They are used as a reference point for sighting or aiming; to measure angular distance between two points; to determine the center of the field; or to assist in the gaging of distance, determining leads, or measurement. The reticle may be a pair of crosslines composed of fine wire or may be etched on a glass plate with plane parallel surfaces. If it is etched on glass, the entire piece of glass is referred to as the reticle. (Also, see figs 4-24 and 4-25).

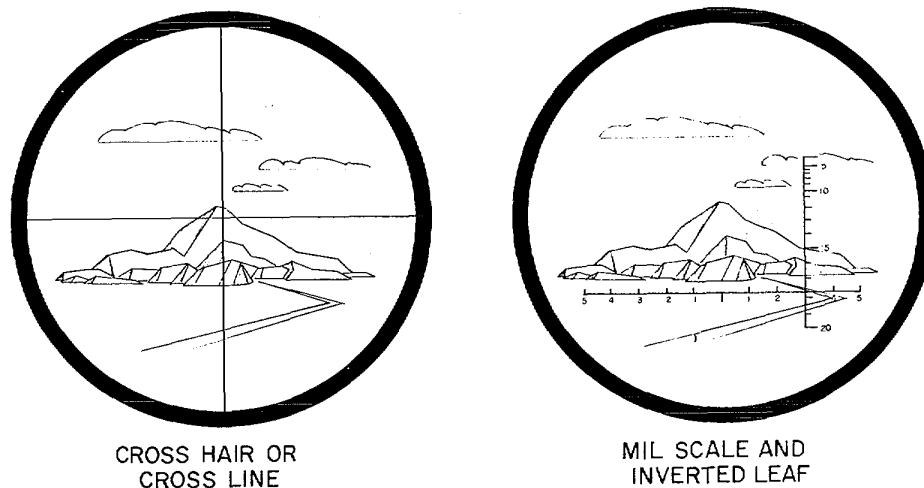

CROSS HAIR OR  
CROSS LINE

MIL SCALE AND  
INVERTED LEAF

AR910227

Figure B-27. Reticle patterns superimposed on image of object .

*Retina* - The light-sensitive inner coat or tunic of the eyeball upon which the image is formed by the lenses of the eye. It contains the visual cells called the cones and rods (figs 3-2 and 3-5).

*Reversion* - Turned the opposite way so that

right becomes left and vice versa. It is the effect produced by a vertical mirror in reflecting an image.

*Reverted erect* - See erect image.

*Reverted image* - An image, the right side of which appears to be the left side of the *object and vice versa*.

*Reverted inverted* - See inverted image.

*Rhomboidal prism* - A prism with two pairs of parallel sides forming right angles and two 45° slanting or oblique parallel ends. It will displace the path of light entering its ends without changing the direction of light. It does not invert or revert the image (fig 4-12). Rhomboidal prisms may be rotated to divert the lines of sight to permit interpupillary adjustment of the eyepieces of a binocular instrument.

*Right-angle prism* - A type of prism used to turn a beam of light through a right angle (900) (fig 2-36). It will invert (turn upside down) or revert (turn right or left), according to position of the prism, any light reflected by it. This prism is likewise used to turn a beam of light through an angle of 180° (fig 2-43) when either a normal erect image or inverted, reverted image is produced, depending upon the position of the prism with respect to the object and the observer.

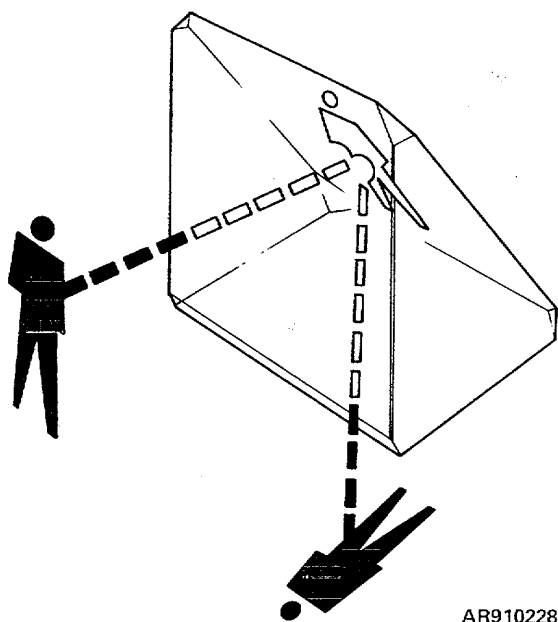

AR910228

Figure B-28. Right-angle prism .

*Rod* - One of the two types of light-sensitive elements or visual cells in the retina of the eye which permit sight. The rods are associated with night vision and sight under other conditions of weak light. They also detect motion. For seeing in weak light, they are stimulated by a substance known as visual purple. The other type of visual cell is termed the cone (fig 3-5).

*Roof-angle prism or roof prism* - See Amici prism.

*Rotating prism* - See Dove prism and Pechan prism.

*Rotating wedge* - A circular optical wedge mounted to be rotated in the path of light to divert

the line of sight to a limited degree. See correction wedge, measuring wedge.

*Rouge* - A material for polishing optical glass made principally from red oxide of iron. The name is also applied to polishing materials which are not red, such as black rouge and white rouge.

*Sclera* - The outer of the three coats or tunics of the eyeball. It is tough, white, and flexible and is the white portion of the eye normally seen. The slightly protruding transparent portion of the center front of the eye, the cornea, is part of this coat (fig 3-2).

*Second* - A unit of measurement of an angle equal to one-sixtieth of a minute or 1/3600th part of a degree.

*Selective absorption* - See absorption.

*Selective reflection* - See absorption.

*Selective transmission* - See absorption.

*Separator* - Also known as spacer. A hollow tubular part used to separate two lenses at a definite distance (fig 4-35).

*Sighting instruments* - Devices or instruments designed to aid in the pointing of a weapon, observation and azimuth or range determination, and looking over obstacles.

*Sine* - The sine of an angle is the side of a right-angle triangle opposite the angle divided by the hypotenuse (the long side opposite the right angle).

*Site Location* - See angle of site.

*Soft coat* - A term designating the soft coating applied to coated optics to differentiate between the harder and more durable coating of magnesium fluoride known as hard coat.

*Spacer* - See separator.

*Spectrum* - The band of colors produced by a prism in dividing white light into its components. The rainbow is an example, dispersion produces this spectrum. See electromagnetic spectrum.

*Spherical aberration* - The aberration of a lens which results when rays of light which pass through a lens near its edge are converged to a point nearer the lens than those rays passing through near the center (fig. 2-55). The effect is poor definition of the image.

*Split field* - The field of view as seen when observing through a coincidence range finder. It is formed by uniting halves of the images produced by two objectives. The half images are separated by the halving line.

*Squint* - See strabismus.

*Stadia scale* - Graduations on a reticle which in conjunction with a rod of definite length can be used to measure distances.

*Standard candle* - Initially a sperm whale oil candle, 7/8 inch in diameter, burning at the rate of 120 grains per hour. Current standards of candle power are electric lamps.



*Standard letters* - Letters of specific size which are viewed at specified distance (20 feet) to test the keenness of sight.

*Stereoacuity* - Keenness or sharpness of sight in discerning depth or three dimensions.

*Stereovision* See stereoscopic vision.

*Stereogram* - A card containing two pictures taken from different angles (corresponding to the spacing between the pupils of the eyes), which when viewed through a stereoscope present a single image with the illusion of depth or three dimensions.

*Stereopsis* - See stereoscopic vision.

*Stereoscope* - A binocular instrument used to view stereograms. See stereogram.

*Stereoscopic contact* - A term applied to the action of bringing the target into the same apparent distance plane as the central measuring mark (pip) of the reticle in the use of a stereoscopic range finder.

See stereoscopic range finder.

*Stereoscopic effect* - The sense of depth, relief, or solidity resulting when an object is viewed by both eyes, due to the fact that each eye views the object from a slightly different angle (fig 3-7).

Similar effect produced when viewing a stereogram.

See stereogram.

*Stereoscopic power* - The gain in stereoscopic effect afforded by a magnifying binocular instrument as compared with the ability of the naked eyes. This power will vary with the separation of the objectives and the power of the instrument.

*Stereoscopic range finder* - A self-contained distance measuring device operating on the principle of triangulation. Images, observed from points of known distance by the eyes, result in a sense of depth, and are made to appear in the same distance plane as the central measuring mark (pip) of the stereo reticle. See stereoscopic contact.

*Stereoscopic vision* - Vision in depth or three dimensions due to the spacing of the eyes. This spacing of the eyes permits them to see objects from slightly different angles. An impression of the shape, depth, and position of an object with relation to other objects is received when the brain fuses the two separate pictures seen by both eyes into a single image (fig 3-7).

*Strabismus* - Affection of the eye in which the lines of sight cannot be directed to the same object at once because of abnormal contraction, relaxation of, or injury to one or more of the muscles controlling the movement of the eyeball. A condition of the eyes in which the lines of sight tend to turn inwardly is known as *convergent strabismus, esophoria, crosseye, or squint*. A condition of the eyes in which the lines of sight tend to turn outward is known as *divergent strabismus, exophoria, or wall eye*.

*Strain* - Distortion or fault in optical glass caused by internal stress or tension and brought

about by improper cooling or annealing during manufacture of the glass.

*Striae* - Localized variations in the index of refraction of a piece of optical glass, usually occurring in streaks. It is caused by improper mixing of the ingredients during manufacture.

*Sunshade* - A tubular projection provided to protect the objective from the direct rays of the sun (fig 4-37).

*Surface plate* - A plate having a very accurate plane surface used for testing other surfaces or to provide a true surface for accurately locating testing fixtures. It is usually mounted on three adjustable legs so that it can be accurately leveled in a horizontal plane.

*Tangent* - A straight line which touches a curve or a curved surface but does not cut in.

*Telescope* - An optical instrument containing a system of lenses, usually with magnifying power, which renders distant objects more clearly visible by enlarging their images on the retina of the eye, or which superimposes a reticle pattern on the image of the object to assist in aiming or in the gaging of distance (figs 5-6, 6-8, 5-9, and 5-13).

*Thermoplastic cement* - Cement capable of being repeatedly softened by increase of temperature and hardened by lowering of temperature, such as resin derived from Canada balsam. It is used because it has approximately the same index of refraction as glass. See Canada balsam.

*Thermosetting cement* - A clear, colorless cement used in cementing optical elements together, particularly the components of a compound lens. It is used because it has approximately the same index of refraction as glass. It changes into a substantially infusible product when cured under application of heat.

*Toroidal (toric) lens* - A lens having for one of its surfaces a segment of a torus (the surface described by a circle or a curve rotating about a straight line in its own plane). Used in spectacles to correct astigmatism of the eyes. See astigmatism.

*Total internal reflection* - Reflection which takes place within a substance because the angle of incidence of light striking the boundary surface is in excess of the critical angle. See critical angle.

*Tourmaline* - A mineral that has the faculty of polarizing light.

*Trajectory* - The curved path through the air described by a projectile in its flight (fig B-3).

*Traverse* - Movement in azimuth; rotation in a horizontal plane. See azimuth.

*Triple mirror prism* - A prism with four triangular surfaces arranged like two triangular roofs placed at right angles to one another. Three of the four surfaces are used as mirrors in reflecting light. This prism has the property of deviating,

through an angle of 1800, any ray of light entering it (fig 4-15).

*Triplet* - A three-element compound lens with inner surfaces curved identically and cemented together (fig 4-3).

*True field of view* - See field of view.

*True North* - Geographic north; the direction along the geographical meridian of the geographic north pole from a point on the earth's surface.

*Unit of correction* - An arbitrary scale graduation as laid off on the correction wedge scale of a range finder.

*Unit of error (UOE)* - Unit of measurement corresponding to 12 seconds of arc. When checking the accuracy of an observer's readings of range, as determined by a range finder, it is necessary to have some unit of measure. It has been determined by test that the mean error of the normal, well-trained observer under good conditions of observation should not exceed 12 seconds of arc for a series of readings, regardless of the range involved. This mean error is taken as the basis for determining the accuracy of range finder readings. The unit of error (UOPE) is the unit of measure arbitrarily selected and all errors in range readings are converted to this unit during analysis.

*Velocity of light* - The speed of light. It is numerically equal to the frequency multiplied by the wavelength. The speed of light in vacuum equals 186,330 miles per second.

*Vertex* - Highest or lowest, the most or least

projecting point on the axis of a convex or concave mirror or lens.

*Vertical travel* - Movement of the line of sight of an optical instrument or gun in a vertical plane.

*Virtual base* - The actual base or baseline of a range finder multiplied by the power of magnification of the instrument.

*Virtual image* - The image formed by a diverging lens. It is formed by rays which come from the direction of the image but do not originate in it.

It cannot be thrown upon a screen. It exists only in the mind of the observer (fig 2-50). Similar image formed by a converging lens if the object is inside one focal length (fig 2-48). Apparent position of reflected point which appears to be located behind the mirror (figs 2-40 and 2-41).

*Vision persistence* - See persistence of vision.

*Visual acuity* - Acuteness or sharpness of sight.

It is measured by the ability to distinguish letters of specified size at a given distance.

*Visual purple* - A substance surrounding the light-sensitive visual cells in the retina of the eye and stimulating the rods for keener sight under poor light conditions.

*Vitreous humor* - A transparent, jelly-like substance with which the rear and greater portion of the eye is filled and which is part of the refracting mechanism of the eye (fig 3-2).

*Walleye* - See strabismus.

*Wave* - Vibration; a form of movement by which all radiant energy of the electromagnetic spectrum is assumed to travel (fig B-29).

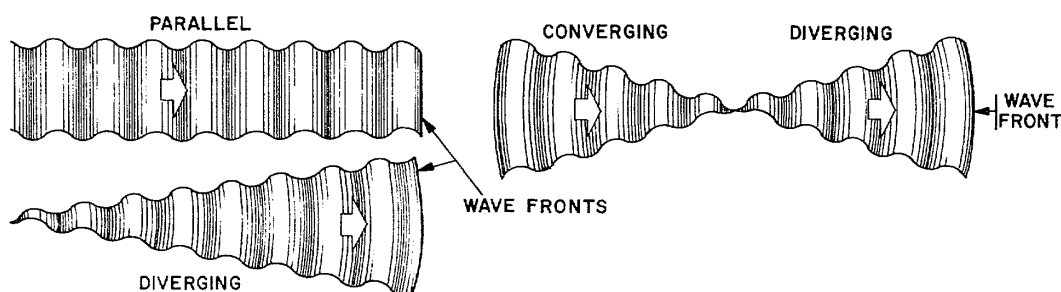

AR910229

Figure B-29. Waves and wave fronts .

*Wave front* - A surface normal (at right angles) to a bundle of rays as they proceed from a source. The wave front passes through those parts of the waves which are in the same phase and go in the same direction. For parallel rays, the wave front is a

plane; for rays diverging from or converging toward a point, the wave front is spherical (fig B-29).

*Wavelength* - Length of a wave measured from any point on one wave to the corresponding point, in the same phase on the next wave; usually measured

from crest to crest (fig 2-9). Wavelength determines the nature of the various forms of radiant energy which comprise the electromagnetic spectrum; it determines the color of light (fig 2-3).

*Wedge* - An optical element with plane inclined surfaces, Usually the faces are inclined toward one another at very small angles. Wedges divert light toward their thicker portions. They may be circular, oblong, or square. See correction wedge and measuring wedge.

*White light* - Light, such as sunlight and daylight, which is composed of all the different wavelengths of the visible spectrum.

*Window* - A piece of glass with plane parallel surfaces used to admit light into an optical instrument but exclude dirt and moisture. Also see correction window.

*Worm* - A shaft with a gear in the form of a screw which meshes with a worm-wheel. The axes of the worm and worm-wheel are generally-perpendicular to each other.

*Wormwheel* - A gear designed to mesh with a worm.

*X-ray unit* - A unit of measure equaling one

ten-millionth part of a micron, or one-ten thousand millionth part of a millimeter.

*Yaw* - The angle between the axis of the projectile at any moment and the tangent to the trajectory.

*Y-azimuth* - The azimuth reading taken from the Y-North direction. See Y-North.

*Yellow spot* - See macula.

*Y-North* - Grid North. The north direction as determined by the grid lines on a map. The United States is laid out in seven grid zones. The central grid line of each of these zones points to True North. The other grid lines being parallel to the central grid line will, due to the spherical shape of the earth's surface, not lie in a true north-south line. The deviation between True North and grid north at any point due to this curvature, grid declination will never exceed 39. Arbitrarily selected North direction on a drawing or a map, different from True North, usually parallel to or at right angles to some objects shown, and used for reference in that area only.

*Z-rotating prism* - See Pechan or Z-rotating prism.

INDEX

	Paragraph	Page		Paragraph	Page
<b>A</b>					
Abbe prism system .....	4-5j,4-7d	4-19,4-22	Diopter movement adjustment .....	5-14	5-10
Aberrations, elimination .....	2-37,2-41	2-42,2-48	Dioptrimeter .....	5-15	5-11
Absorption, light (See Light)			Distance		
Adapter .....	4-17	4-35	Eye .....	2-34	2-41
Adjustments:			Interpupillary .....	3-9f	3-11
Collimation .....	5-16	5-11	Distortion .....	2-42	2-49
Diopter movement .....	5-14	5-10	Divergent lens:		
Dioptrimeter .....	5-15	5-11	Description .....	2-156b	2-23
Aiming circle .....	8-26	8-28	Image formation .....	2-25	2-35
Amici prism .....	4-5d,4-7d	4-12, 4-22	Dove prism .....	4-5f	4-13
Astigmatism in lenses .....	2-40	2-46	Dynameter, Ramsden.....	5-24	5-14
Aqueous humor (human eye .....	3-4a	3-3	<b>E</b>		
<b>B</b>			Einstein's theory of light.....	2-1a(7)	2-1
Barrel distortion.....	2 -42h	2-53	Electromagnetic spectrum .....	2-lb (7)	2-1
Bars, optical .....	4-22	4-37	Electromagnetic theory of light		
Binocular vision.....	3-7	3-7	(Maxwell, Boltzmann, and Hertz). 2-1a(5)		2-1
Binoculars:			Erecting systems .....	4-7	4-21
Battery commander's periscope ..	8-20	8-18	Erfler eyepiece.....	4-4j	4-9
General.....	8-18	8-16	Exit pupil:		
General use .....	8-19	8-18	Definition .....	2-34	2-41
<b>C</b>			Measurement .....	9-3	9-1
Caps, objective .....	4-20	4-36	Eye, human:		
Cells, lens .....	-17	4-35	Comparison with camera.....	3-2	3-1
Centering devices .....	4-18	4-35	Defects .....	3-5	3-3
Choroid (human eye) .....	3-4	3-3	Fatigue .....	3-14	3-17
Chromatic aberration .....	2-39	2-44	Introduction .....	3-1	3-1
Coated optics .....	4-13	4-31	Optical instruments and the eyes:		
Collimation adjustment .....	5-16	5-11	Accommodation .....	3-13	3-17
Collimator sight .....	8-24	8-26	General .....	3-12	3-17
Coma .....	2-41	2-48	Refracting mechanism .....	3-5	3-3
Compound microscope.....	5-3	5-1	Response mechanism.....	3-6	3-5
Compton's theory of light .....	2.1a(8)	2-2	Structure.....	3-3	3-2
Convergent lens:			Tension or fatigue.....	3-14	3-17
Description.....	2-15	2-20	Three coats or tunics .....	3-4	3-3
Image formation.....	2-24	2-32	Eye distance or relief:		
Magnification .....	2-24	2-32	Definition .....	2-34b	2-41
Cornea (human eye).....	3-4a	3-3	Measurement .....	3	9-1
Critical angle			Eyepieces .....	4-4	4-4
Of various substances .....	2-17	2-25	Eyeshields .....	4-19	4-36
Total internal reflection .....	2 -16	2-23	Field of view:		
Crystalline lens (human eye) .....	3-3b	3-2	<b>F</b>		
Correction .....	2-42i	2-53	Human eye .....	3-8	3-8
Curvature:			Measurement.....	9-5	9-1
Field.....	2-42d	2-50	Optical systems .....	2-30,2-31	2-39
Image, formation.....	2-42e	2-51	Field stops .....	4-10	4-28
<b>D</b>			Filters:		
Definition of optical terms(See Glossary.)			Colored.....	4-11b	4-29
Devices:			General.....	4-11a	4-29
Centering .....	4-18	4-35	Polarizing.....	4-11c	4-29
Focusing .....	4-21	4-36	Five-sided prism .....	4-5h	4-16
Diagrams, explanation of symbols .2-4	2-8		Fizeau's method of measuring		
Diaphragms .....	4-10	4-28	speed of light .....	2-2d	2-7
Diffraction.....	2-436	2-53	Focal length and plane .....	2 -22	2730
Dioptr:			Focusing devices.....	4-21	4-36
Lens.....	10-26	10-1	Focusing of optical instruments .....	2-36	2-42
Prism .....	10-2b	10-1	Fresnel's theory of light .....	2-1a(4)	2-1
			<b>G</b>		
			Galilean telescope .....	5-11	5-6

	Paragraph	Page
Galilean-type rifle sight .....	5-20	5-12
Glass, optical .....	4-1	4-1
Glossary .....	B-2	B-1
Greek theory of light .....	2-1a(1)	2-1
<b>H</b>		
Helmet directed subsystem .....	8-28	8-3
Hourglass distortion .....	2-42g	2-52
Huygenian eyepiece .....	4-4h	4-7
Huygen's theory of light .....	2-1a(3)	2-1
Images:		
Brightness .....	2-33	2-40
Classification .....	2-19	2-26
Formation by convergent lens, magnification .....	2-24	2-32
General .....	2-18	2-26
Reflection by plane mirror .....	2-20	2-27
Transmission by mirror and prism .....	2-212-29	
Infrared:		
Detectors .....	7-4	7-1
General .....	7-1	7-1
Radiation .....	7-2	7-1
Thermal .....	7-3	7-1
Instrument lights .....	4-12	4-30
Intelpupillary distance .....	2-35	2-41
Iris (human eye) .....	3-5b	3-3
<b>K</b>		
Kellner eyepiece .....	4-4f	4-5
<b>L</b>		
Laser rangefinder .....	8-27	8-29
Lasers:		
Gas .....	6-3	6-1
General .....	6-1	1
Optics .....	6-5	6-3
Solid state .....	6-4	6-2
Types .....	6-2	6-1
Length, focal .....	2-22	2-30
Lens cells .....	4-17	4-35
Lens, divergent:		
Description .....	2-25	2-35
Image formation .....	2-25	2-35
Lens erecting system .....	4-7c	4-21
Lenses:		
Astigmatism .....	2-40	2-46
Chromatic aberration, correction .....	2-39b	2-45
Construction:		
Compound .....	4-2b	4-2
Single .....	4-2a	4-1
Functions of lenses:		
Collective .....	5-12	5-8
Eyepiece .....	5-13	5-9
Field .....	5-12	5-8
Ocular .....	5-13	5-9
Magnification, telescope optical system .....	2-31	2-39
Objectives .....	4-3	4-3
Resolving power .....	2-43	2-53
(See also Convergent Lens and Divergent lens)		
Lens retaining rings .....	4-17	4-35
Light:		
Color .....	2-1b(6),2-26	2-6,2-37
Critical angle .....	2-16,2-17	2-23,2-25

	Paragraph	Page
Frequency .....	2-3	2-7
Image formation .....	2-24	2-32
Known facts .....	2-1b	2-1
Loss .....	2-45	2-55
Principle of dispersion .....	2-27	2-37
Selective reflection and absorption .....	2-28	2-39
Separation of "white" light .....	2-27	2-37
Significance of color .....	2-1b(2)	2-3
Speed .....	2-2	2-6
Theories .....	2-1	2-1
Transmission of (energy) .....	2-1b(1)	2-2
Wavelength .....	2-3	2-7
Light paths, principle of reversibility .....	2-1b(5)	2-6
Light rays:		
Definition-reflected, emergent, incident, and refracted .....	2-6,2-11	2-11,2-16
From distant sources .....	2-1b(4)	2-5
General .....	2-1b(3)	2-5
Properties .....	2-1b	2-2
Used in diagrams .....	2-4	2-8
Lighting .....	4-12	4-30
<b>M</b>		
Magnification:		
Definition .....	2-23	2-32
Telescope .....	5-21	5-13
Magnification, eyepiece with variable .....	4-4n	4-11
Magnifier, simple .....	5-2	5-1
Maxwell's theory of light .....	2-1a(5)	2-1
Microscope, compound .....	5-3	5-1
Military telescopes .....	2-30	2-39
Millikan's theory of light .....	2-1a(8)	2-2
Mirrors, front surface .....	4-8	4-25
Mirror, plane .....	2-5	2-9
<b>N</b>		
Newton:		
Rings .....	2-44	2-54
Theory of light .....	2-1a(2)	2-1
Objective caps .....	4-20	4-36
Optical bars .....	4-22	4-37
Optical defects:		
Aberrations:		
Chromatic .....	2-39	2-44
General .....	2-37	2-42
Spherical .....	2-38	2-42
Optical glass .....	4-1	4-1
Optical instruments:		
Accommodation .....	3-13	3-17
Focusing .....	2-36	2-42
General .....	3-12	3-17
History .....	5-1	5-1
Specialized, military:		
Collimator sight .....	8-24	8-26
Reflector (reflex) sight .....	8-25	8-27
Optical properties of instruments, testing:		
Determination:		
Curvature of image .....	9-7	9-2
Spherical aberration .....	9-6	9-1
General .....	9-1	9-1
Magnifying power .....	9-4	9-1
Measurement:		
Field of view .....	9-5	9-1
Objective aperture .....	9-2	9-1

	Paragraph	Page		Paragraph	Page
Optical systems:			Through wedges.....	4-6	4-19
Field of view.....	2-32	2-39	Retaining rings.....	4-17	4-35
General.....	2-29	2-39	Description.....	4-9	4-26
Magnification.....	2-31	2-39	Reticles:		
Military telescopes.....	2-30	2-39	Function.....	5-19	5-12
Wedges.....	4-6	4-19	Retina (human eye).....	3-3	3-2
Optics coated			Rhomboidal prism.....	4-5e	4-13
Identification.....	4-15	4-34	Rifle sight, Galilean-type.....	5-20	5-12
Introduction, advantages.....	4-13	4-31	Rings:		
Serviceability.....	4-16	4-34	Newton's.....	2-44	2-54
Theory.....	4-14	4-32	Retaining.....	4-17	4-35
Optics, measurement systems employed:			Roof-angle prism.....	4-5d,4-7d(3)	4-12,4-23
Candlepower and foot candles....	10-1	10-1	<b>S</b>		
Degree system.....	10-3	10-1	Scope of manual.....	1-2	1-3
Diopters.....	10-2	10-1	Separators.....	4-17	4-35
Metric system.....	10-5	10-4	Sight, collimator.....	8-24	8-26
Mil system.....	4	10-1	Spaces.....	4-17	4-35
Orthoscopic eyepiece.....	4-4k	4-9	Spectrum, electromagnetic.....	2-1b(2)	2-3
<b>P</b>			Spherical aberration:		
Parallax.....	2-46	2-55	Elimination.....	2-38e,f	2-43,2-44
Pechan prism.....	4-5g	4-16	General.....	2-38	2-42
Pencils of light.....	2-42f	2-52	Stereovision, principles.....	3-9	3-8
Pentaprism.....	4-5h	4-16	Stops.....	4-10	4-28
Periscopes:			Sunshades.....	4-20	4-36
Battery commander's.....	8-20	8-18	Symbols.....	2-4	2-8
Description.....	5-4	5-2	Symmetrical eyepiece.....	4-4i	4-9
General.....	8-13	8-10	<b>T</b>		
For self-propelled vehicle.....	8-1	8-13	Tabulated data.....	8-23	8-26
For tank observation.....	814	8-12	Telescope design, optical factors:		
For tanks.....	8-16	8-13	Factors determining:		
Infrared.....	8-17	8-15	Eye relief.....	5-27	5-16
Plack's theory of light.....	2-1a(6)	2-1	Field of view.....	5-26	5-15
Plane mirror, reflection from.....	2-5	2-9	Light transmission or illumination of image.....	5-28	5-17
Plane, focal.....	2-22	2-30	Magnification or power of telescope.....	5-21	5-13
Plossl eyepiece.....	4-4m	4-11	Night glasses.....	5-29	5-17
Porro erecting system.....	4-7d	4-22	Optical glass used in design		
Porro prism system.....	4-5c	4-12	of military instruments.....	5-31	5-18
Principles of stereovision.....	3-9	3-8	Pupil:		
Prisms.....	4-5	4-11	Entrance.....	5-22	5-13
Prisms, chromatic aberration, correction.....	2-39e	2-46	Exit.....	5-23	5-1
Purpose of manual.....	1-1	1-1	Ramsden dynamometer.....	5-24	5-14
<b>R</b>			Resolving power of optical systems ...	5-30	5-17
Ramsden dynamometer.....	5-24	5-14	True and apparent fields of telescope.....	6-25	5-14
Rangefinders:			Telescopes:		
General.....	8-21	8-19	Articulated		
Tabulated data.....	8-23	8-26	For self-propelled vehicle.....	8-7	8-4
Tank (typical coincidence).....	8-22	8-21	For tank.....	8-6	8-4
Rays.....	2-4,2-42f	2-8,2-52	General.....	8-5	8-3
Reduction.....	2-23	2-32	Astronomical:		
Reflection:			Magnification.....	5-7	5-4
Concave mirror.....	2-9	2-13	Reflecting.....	5-6	5-3
Convex mirror.....	2-8	2-13	Refracting.....	5-5	5-2
Law.....	2-6	2-11	Elbow:		
Plane mirror.....	2-5	2-9	For howitzer (towed &		
Total internal.....	2-16	2-23	self-propelled).....	8-9a,8-9c,8-9d	8-5,8-7
Types.....	2-7	2-11	For sight units.....	8-9b	8-6
Reflector (reflex) sight.....	8-25	8-27	General.....	8-8	8-5
Atmospheric.....	2-13	2-18	Typical.....	8-9	8-5
Refraction:			General.....	8-1	8-1
Index.....	2-12	2-18	Military.....	2-30	2-39
Law.....	2-11	2-16	Observation.....	8-4	8-2
Through a glass plate.....	2-10	2-15	Panoramic:		
Through a triangular glass prism ..	2-14	2-20	For self-propelled howitzer.....	8-12	8-9
Through lenses.....	2-15	2-20	For towed howitzer.....	8-11	8-9
			General.....	8-10	8-8

Paragraph .....	Page	
Rifle .....	8-2	8-1
Sniper's sighting device .....	8-3	8-1
Observation .....	8-4	8-2
Terrestrialsail:		
Galilean .....	5-11	5-6
General .....	5-8	5-4
Lens erecting systems .....	5-9	5-4
Prism erecting systems .....	5-10	5-6
Telescopic sights, functions:		
Advantages .....	5-18	5-12
Definition .....	5-17	5-12
Functions of reticles .....	5-19	5-12
Galilean-type rifle sight .....	5-20	5-12
Testing optical properties of instruments	9-1 thru	9-1,9-2
	9-7	
Triple mirror prism .....	4-5 <i>i</i>	4-18
	<b>V</b>	
View, field .....	3-8	3-8

Paragraph .....	Page	
Vision:		
Binocular .....	3-7	3-7
Defects of (human eye) .....	3-10	3-14
Stereoacuity .....	3-9 <i>k</i>	3-14
Stereovision .....	3-9	3-8
Visual limitations .....	3-11	3-15
	<b>W</b>	
Wave energy transmission .....	2-1 <i>b</i>	2-2
Wavelength and frequency .....	2-3	2-7
Wavelength, units of measurement ....	2-1 <i>b</i>	2-2
Wedges, optical .....	4-6	4-19
	<b>Y</b>	
Young's theory of light .....	2-1 <i>a</i> (4)	2-1
	<b>Z</b>	
Z prism .....	4-5 <i>g</i>	4-16

By Order of the Secretary of the Army:

BERNARD W. ROGERS  
*General, United States Army*  
*Chief of Staff*

Official:

J. C. PENNINGTON  
*Brigadier General, United States Army*  
*The Adjutant General*

DISTRIBUTION:

To be distributed in accordance with DA Form 12-41, Direct/General Support maintenance for Rangefinder, Binocular, Periscope, and Telescope.

\* U.S. GOVERNMENT PRINTING OFFICE : 1990 0 - 261-888 (22709)



RECOMMENDED CHANGES TO EQUIPMENT TECHNICAL PUBLICATIONS



THEN... JOT DOWN THE DOPE ABOUT IT ON THIS FORM, CAREFULLY TEAR IT OUT, FOLD IT AND DROP IT IN THE MAIL!

**SOMETHING WRONG WITH THIS PUBLICATION?**

FROM: (PRINT YOUR UNIT'S COMPLETE ADDRESS)

DATE SENT

PUBLICATION NUMBER

PUBLICATION DATE

PUBLICATION TITLE

BE EXACT... PIN-POINT WHERE IT IS

IN THIS SPACE TELL WHAT IS WRONG AND WHAT SHOULD BE DONE ABOUT IT:

PAGE NO.	PARA-GRAPH	FIGURE NO.	TABLE NO.
----------	------------	------------	-----------

TEAR ALONG PERFORATED LINE

PRINTED NAME, GRADE OR TITLE, AND TELEPHONE NUMBER

SIGN HERE:

DA FORM 2028-2 JUL 79

PREVIOUS EDITIONS ARE OBSOLETE.

P.S.—IF YOUR OUTFIT WANTS TO KNOW ABOUT YOUR RECOMMENDATION MAKE A CARBON COPY OF THIS AND GIVE IT TO YOUR HEADQUARTERS.

